

Chains, bearings and components.

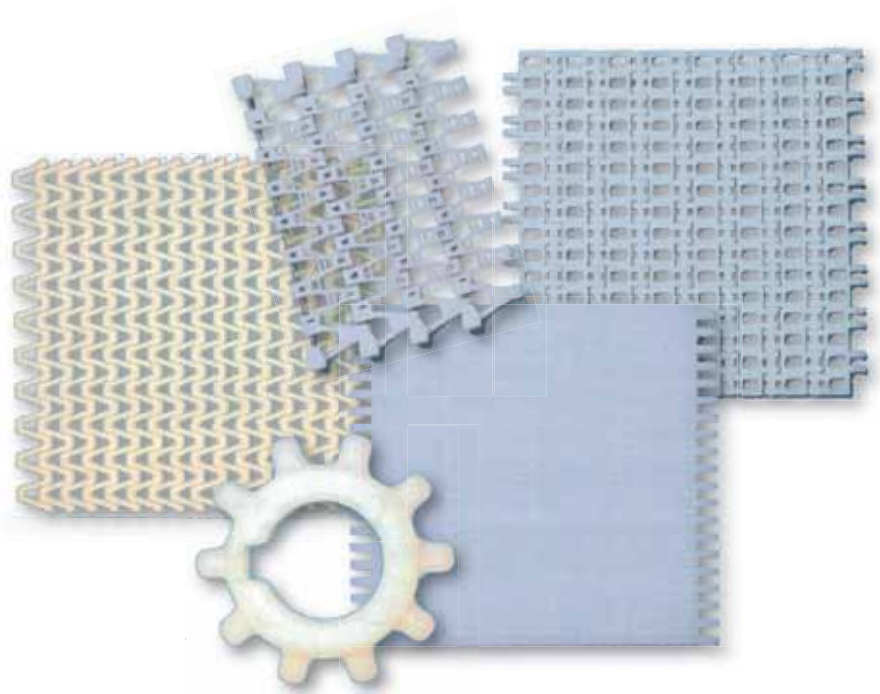

...keeping industry moving...



....not only do we manufacture Plastic Modular belts,  
but we also distribute Slat-Top chains, Bearings,  
Conveyor components, Timing- & V- belts and Wear  
Profiles.

### ***History ..... :***

ScanBelt AA is a subsidiary of ScanBelt A/S in Hjoerring, Denmark. After becoming a member of the "ScanBelt family" in 2002, we have consistently expanded our product range and market activities. One of the core functions is to handle the domestic sales of the modular belts produced in Hjoerring, although the activities by no means are limited to this. As it is apparent from the following pages, we also act as the international distributor for the vast number of products displayed throughout the catalogue.

The above mentioned advantages makes us an attractive partner for distributors and customers as it enables them to source a variety of different high quality conveying parts from the same supplier. Having worked from distributor network philosophy for many years, the ScanBelt group naturally has sufficient technical and practical back up in all corners of the world to support the high quality product that we sell.

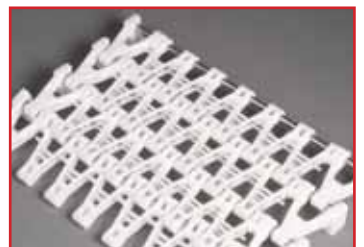

# Table of contents

## Thermoplastic conveyor chains

Materials .....	2
Thermoplastic straight running chains - Single hinge.....	3
Thermoplastic straight running chains - Double hinge.....	4
Thermoplastic sideflexing chains.....	5
Thermoplastic sideflexing chains on magnetic tracks.....	7
Thermoplastic sideflexing chains.....	8
Vacuum thermoplastic straight running chains/ - Single hinge .....	9
Straight running chains with thermoplastic Top plates .....	10
"1843" Sideflexing chains with thermoplastic Top plates.....	12
Thermoplastic straight running chains with rubber inserts - Single/Double hinge.....	13
Thermoplastic sideflexing chains with rubber inserts.....	14
"1873" Sideflexing chains with thermoplastic top plates and rubber inserts.....	16
Double hinge straight running chains - with low noise accumulation rollers.....	17
Straight running chains - Heavy duty single hinge - with low noise accumulation rollers.....	18
Sideflexing chains - with low noise accumulation rollers.....	19
Flex thermoplastic chains.....	20
Case conveyor chains .....	21
Plastic corrosion resistance table .....	22

## Metal conveyor chains

Materials .....	24
Straight running chains - Single hinge.....	25
"Mignon" straight running chains - Single hinge.....	29
Straight running chains - Double hinge.....	30
Sideflexing hinged slat chains .....	31
Sideflexing hinged slat chains for magnetic system .....	35
Straight running chains with rubber inserts for inclined conveyors - Single hinge .....	36
Sideflexing hinged slat chains with rubber inserts for inclined conveyors.....	37
"1864" Straight running plate top chains .....	38
"1874" Sideflexing plate top chains .....	39
Sprockets .....	40
Idlers .....	44

## Thermoplastic bearing units

Thermoplastic bearing units .....	46
Stainless steel bearing units .....	56
Support bases .....	62
Threated tube ends .....	63
Side mounting top brackets.....	64
Side mounting top brackets/ Connecting joints/ Support heads .....	65
Support heads/ Split collars .....	66
Accessories/ Return profile support.....	67
Return profile support/ Return accessories/ Chain return components.....	68
Chain return components/ Return profile support.....	69
Rollers/ Transfers.....	71
Roller guides/ Adjustable brackets .....	73
Supports/ Support spacer/ Knobs.....	77
Knobs/ Heads.....	78
Heads/ Adjusting rods.....	79
Clamps for round profile guides.....	80
Clamps for "MC" guides .....	82
Clamps for conical side guides .....	84
Extra side guides .....	86
Guides/ Accessories.....	88
Drip tray supports/ Cross block and photocell accessories.....	89
Cross block and photocell accessories/ Frame system .....	91
Frame accessories.....	92
Frame accessories/ Handles .....	93
Handles/ Hinges .....	94
Regulate greaser/ Guides for bottling and packaging .....	95
Guides for bottling and packaging/ Profiles of bevel channel.....	98
Roller chain guides .....	99
Roller chain guides/ Flat belt, V-belt and cable guides .....	103
Steel profile .....	104

## Feet

Fixed feet.....	105
Articulated feet - base in reinforced polyamide .....	106
Stainless steel accessories.....	108

## Belts

Wired belts/ Stainless steel belts .....	110
--	-----

The plastic slat-top chains from ScanBelt are of the highest quality and are long-lasting. These are supplied in a variety of materials, for both standard and specific applications. We are constantly developing chains in close contact with major OEMs and end users in the market. If you require chains that are not displayed in the following pages, please contact us for a discussion about the correct solution for your application.

We are currently supplying thermoplastic slat-top chains to all kinds of industries that have conveying applications, such as packaging, handling/ labelling, bakery, meat, fish and poultry, bottling and canning applications in the brewery sector as well as numerous other conveying tasks.

## DIMENSIONS ON SPROCKETS FOR THERMOPLASTIC AND METAL CONVEYOR CHAINS

Please note that for some thermoplastic and metal conveyor chains in this catalogue, the given dimensions on sprocket diameters are incorrect.

For correct dimensions, please contact ScanBelt AA; +45 76 74 86 00 or aa-chains@scanbelt.com.

Your local sales representative or distributor can also provide the correct information.

The information will, of course, be corrected in the upcoming issue of our catalogue.

We are deeply sorry for any inconvenience this may have caused.

## Materials

	<p><b>D</b></p> <p><b>ACETAL RESIN</b></p> <p>The acetal resin offers very good mechanical specifications, excellent wear resistance and a low coefficient of friction. Used in the manufacturing of plates for flat top chains, it is an economical alternative to our LFA material. FDA (Food drug Administration) approved for direct contact with food.</p> <p><b>Working temperatures:</b> -40° C / + 80° C (dry environment) -40° C / + 65° C (wet environment)</p> <p><b>Colour:</b> grey</p>
<p><b>LFA</b> <b>WLF</b></p> <p><b>LOW FRICTION ACETAL RESIN</b></p> <p>This material has a low coefficient of friction, high wear resistance and excellent resistance to chain tension. It is recommended for high load, high speed applications. FDA (Food and Drug Administration) approved for direct contact with food.</p> <p><b>Working temperatures:</b> -40° C / + 80° C (dry environment) -40° C / + 65° C (wet environment)</p> <p><b>LFA Colour:</b> light brown, green-blue / <b>WLF colour:</b> white</p>	<p><b>SP</b></p> <p><b>SUPER PERFORMANCE ACETAL RESIN</b></p> <p>The Super performance resin has a lower coefficient of friction than LFA material. Plate wear and chain elongation are reduced; it is suitable for high speed applications and reduced lubrication. FDA (Food drug Administration) approved for direct contact with food.</p> <p><b>Working temperatures:</b> -40° C / + 80° C (dry environment) -40° C / + 65° C (wet environment)</p> <p><b>Colour:</b> dark grey</p>
<p><b>WR</b></p> <p><b>WEAR RESISTANT RESIN</b></p> <p>It is especially wear resistant in abrasive environment and it is suitable for conveying glass, mechanical components, sand, etc.</p> <p><b>Working temperatures:</b> -40° C / + 80° C (dry environment) -40° C / + 65° C (wet environment)</p> <p><b>Colour:</b> light grey</p>	<p><b>AS</b></p> <p><b>ANTISTATIC ACETAL RESIN</b></p> <p>This material offers great protection against static electrical charges. It is ideal for explosive atmosphere and where an electrostatic force may cause product instability.</p> <p><b>Working temperatures:</b> -40° C / + 80° C (dry environment) -40° C / + 65° C (wet environment)</p> <p><b>Colour:</b> black</p>
<p><b>PPB</b></p> <p><b>CHEMICAL RESISTANT REINFORCED POLYPROPYLENE</b></p> <p>This improved polypropylene has acid and corrosion resistance characteristics; it is specially recommended when a chain is exposed to chemical agents.</p> <p><b>Working temperatures:</b> +5° C / + 105° C (dry environment) +5° C / + 105° C (wet environment)</p> <p><b>Colour:</b> white</p>	<p><b>PBT</b></p> <p><b>EXTRA PERFORMANCE POLYESTER RESIN (Available upon request)</b></p> <p>It has a very low coefficient of friction and offers an excellent wear resistance. Plate wear and pitch elongation are reduced. It is specially developed for high speed and dry running applications.</p> <p><b>Working temperatures:</b> -40° C / +125° C</p> <p><b>Colour:</b> green</p>

# Thermoplastic straight running chains - Single hinge

## 820 Series

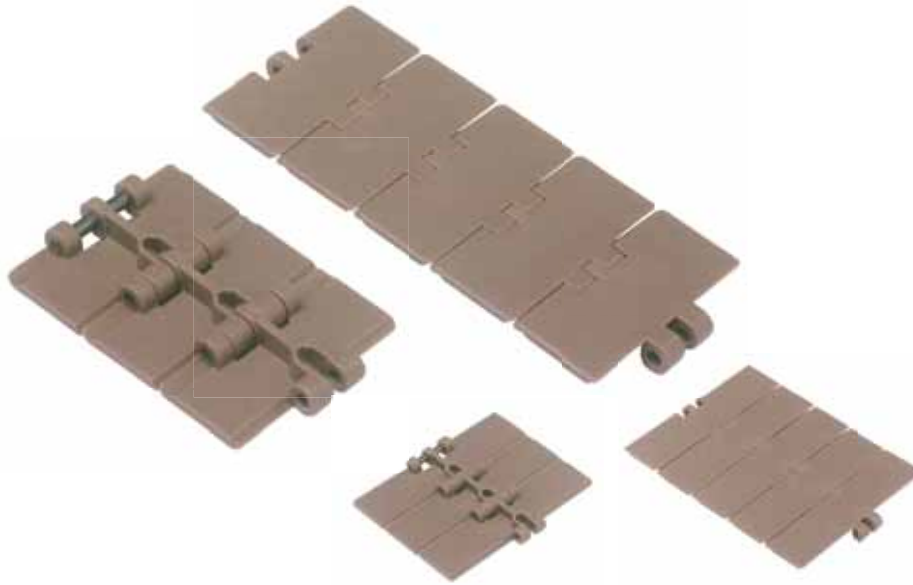

Chain Ref.	Material	Width L mm	Thickness S mm	Height H mm	Weight Kg/m
820 - K 250	See page 2	63,5	4	9,5	0,73
820 - K 325		82,5			0,83
820 - K 343		87,0			0,85
820 - K 350		88,9			0,87
820 - K 400		101,6			0,95
820 - K 450		114,3			1,03
820 - K 600		152,4			1,25
820 - K 750		190,5			1,47

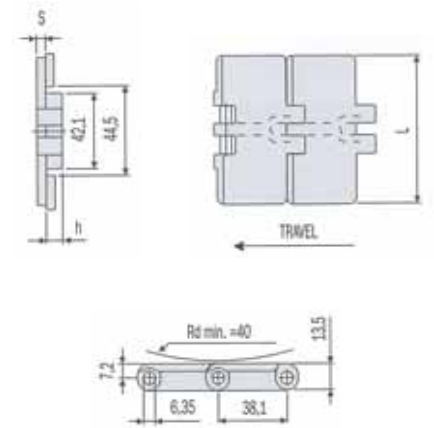

Chain Ref.	Material	Width L mm	Thickness S mm	Height H mm	Weight Kg/m
831 - K 325	See page 2	82,5	4,8	8,7	1,00
831 - K 400		101,6			1,15
831 - K 450		114,3			1,24
831 - K 600		152,4			1,51
831 - K 750		190,5			1,76

## 831 Series



- Standard shipping lengths = 80 pitches = 10 feet = 3,048 metres.
- These chains can be supplied either with pins in austenitic stainless steel, work hardened, highly wear resistant or in thermoplastic resin.

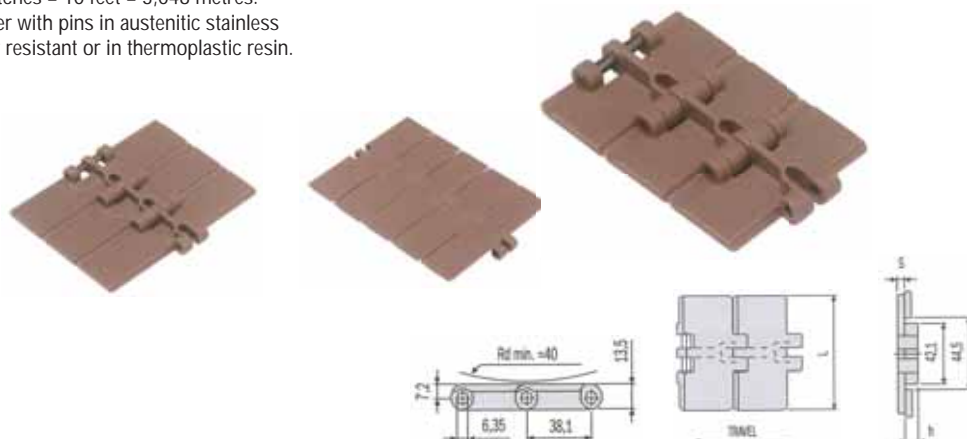

### Designation example

- LFA — Mat + Colour
- 831 — Chain type
- K 325 — Chain Width



# Thermoplastic straight running chains – Double hinge

821 Series



**Designation example**

LFA — Mat + Colour  
 821 — Chain type  
 K 750 — Chain Width

Chain Ref.	Material	Width L mm	Weight Kg/m
821 - K 750	See page 2	190,5	2,50
821 - K 1000		254,0	2,95
821 - K 1200		304,8	3,25

- Standard shipping lengths = 80 pitches = 10 feet = 3,048 metres.
- These chains can be supplied either with pins in austenitic stainless steel, work hardened, highly wear resistant or in thermoplastic resin.

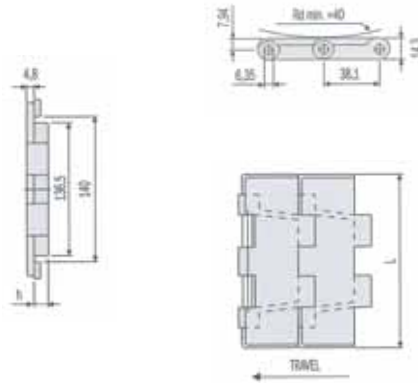

Thermoplastic straight running chains  
– Double hinge

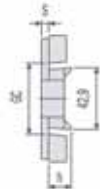
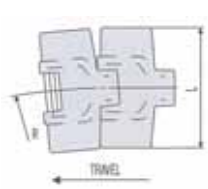
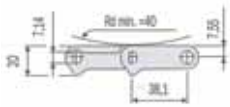

## 880 Series Bevel

Chain Ref.	Material	Width L mm	Thickness S mm	Height H mm	Min. Radius R mm	GC Straight mm	GC Sidefl. mm	Weight Kg/m
880 - K 325	See page 2	82,5	4	16	400	44,5	41,4	0,89
880 - K 350		88,9						0,91
880 - K 450		114,3						1,04
880 - K 750		190,5						1,40

## 879 Series

Chain Ref.	Material	Width L mm	Thickness S mm	Height H mm	Min. Radius R mm	GC Straight mm	GC Sidefl. mm	Weight Kg/m
879 - K 325	See page 2	82,5	4,8	15,2	400	44,5	41,4	0,93
879 - K 450		114,5	4,8	15,2	400	44,5	41,4	1,10

### Designation example

LFA — Mat + Colour  
 879 — Chain type  
 K 325 — Chain Width

## 879 TAB Series

Chain Ref.	Material	Width L mm.	Thickness S mm.	G mm.	Height H mm.	Min. Radius R mm.	GC Straight mm.	GC Sidefl. mm.	Weight Kg./m.
879 TAB - K 325	See page 2	82,5	4,8	11	15,2	400	46	44,2	0,98
879 TAB - K 450		114,3	4,8	11	15,2	400	46	44,2	1,14

- Standard shipping lengths = 80 pitches = 10 feet = 3,048 metres.
- These chains can be supplied either with pins in austenitic stainless steel, work hardened, highly wear resistant or in thermoplastic resin.

## 880 TAB Series

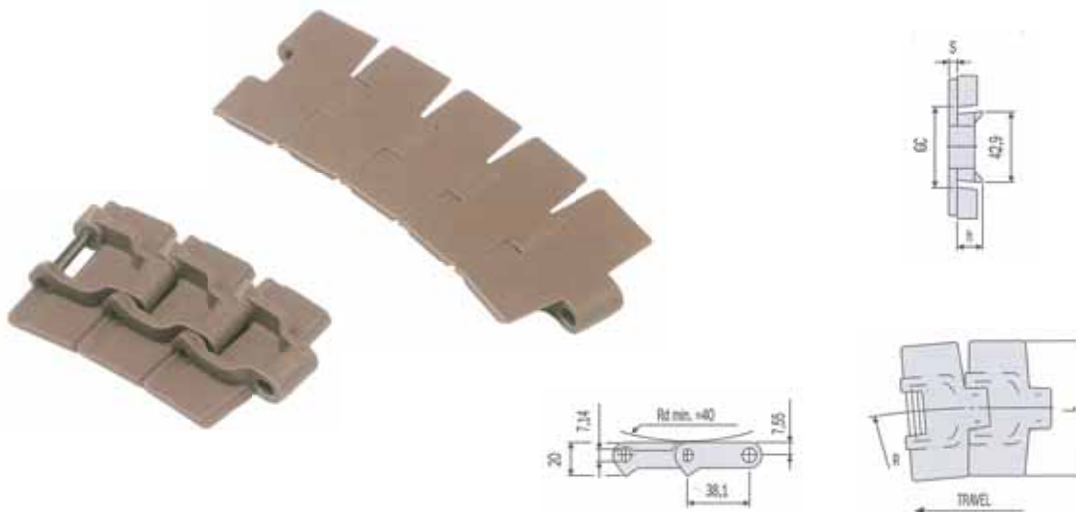

Chain Ref.	Material	Width L mm.	Thickness S mm.	G mm.	Height H mm.	Min. Radius R mm.	GC Straight mm.	GC Sidefl. mm.	Weight Kg./m.
880 TAB - K 250	See page 2	63,5	4	11,5	16	400	46	44,2	0,80
880 TAB - K 325		82,5							0,94
880 TAB - K 343		87,0							0,99
880 TAB - K 350		88,9							1,01
880 TAB - K 450		114,3							1,08
880 TAB - K 600		152,4							1,28
880 TAB - K 750		190,5							1,48

## 880 BO Series



Chain Ref.	Material	Width L mm.	Thickness S mm.	Min. Radius R mm.	GC Straight mm.	GC Sidefl. mm.	Weight Kg./m.
880 BO - K 325	See page 2	82,5	4	190	46	44,2	0,96
880 BO - K 450		114,3	4	190	46	44,2	1,11

Thermoplastic sideflexing chains

- Standard shipping lengths = 80 pitches = 10 feet = 3,048 metres.
- These chains can be supplied either with pins in austenitic stainless steel, work hardened, highly wear resistant or in thermoplastic resin.



# Thermoplastic sideflexing chains

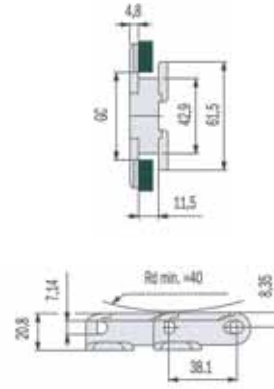

**878 BO Series**

Chain Ref.	Material	Width L mm.	Min. Radius R mm.	GC Straight mm.	GC Sidefl. mm.	Weight Kg./m.
878 BO - K 325	See page 2	82,5	190	46	44,2	1,08
878 BO - K 450		114,3	190	46	44,2	1,20

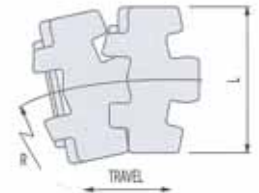

# Thermoplastic sideflexing chains on magnetic tracks

**879 M Series**

Chain Ref.	Material	Width L mm.	Thickness S mm.	Min. Radius R mm.	GC Straight mm.	GC Sidefl. mm.	Weight Kg./m.
879 M - K 325	See page 2	82,5	4,8	457	44	44	1,08

– Standard shipping lengths = 80 pitches = 10 feet = 3,048 metres.

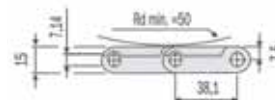
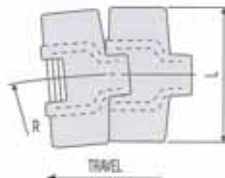
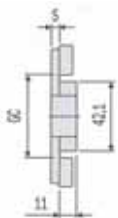

### Designation example

- LFA — Mat + Colour
- 880 M — Chain type
- K 325 — Chain Width

Chain Ref.	Material	Width L mm.	Thickness S mm.	Min. Radius R mm.	GC Straight mm.	GC Sidefl. mm.	Weight Kg./m.
880 M - K 325	See page 2	82,5	4	457	44	44	1,03
880 M - K 330		83,8					1,03
880 M - K 450		114,3					1,16

– Standard shipping lengths = 80 pitches = 10 feet = 3,048 metres.  
 – These chains can be supplied either with pins in austenitic stainless steel, work hardened, highly wear resistant or in thermoplastic resin.

# Thermoplastic sideflexing chains

## 882 Series

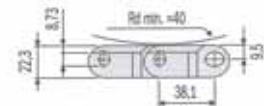
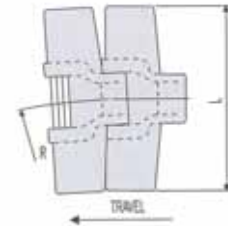

Chain Ref.	Material	Width L mm.	Min. Radius R mm.	GC Straight mm.	GC Sidefl. mm.	Weight Kg./m.
882 - K 450	See page 2	114,3	610	61,9	58	1,94
882 - K 750		190,5				2,38
882 - K 1000		254,0				2,83
882 - K 1200		304,8				2,75

## 882 TAB Series

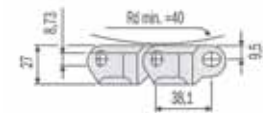
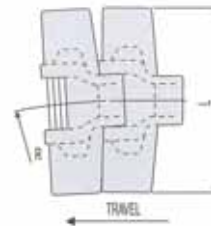
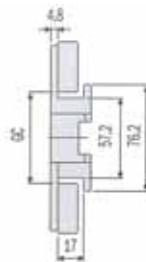
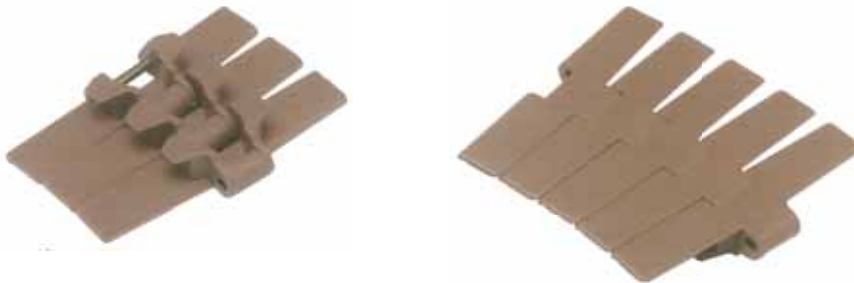

Chain Ref.	Material	Width L mm.	Min. Radius R mm.	GC Straight mm.	GC Sidefl. mm.	Weight Kg./m.
882 TAB - K 450	See page 2	114,3	610	60	58	1,98
882 TAB - K 750		190,5				2,43
882 TAB - K 1000		254,0				2,87
882 TAB - K 1200		304,8				3,41

- Standard shipping lengths = 80 pitches = 10 feet = 3,048 metres.  
 - These chains can be supplied either with pins in austenitic stainless steel, work hardened, highly wear resistant or in thermoplastic resin.

**Designation example**

LFA — Mat + Colour  
 882 — Chain type  
 K 450 — Chain Width

Thermoplastic sideflexing chains

# Vacuum thermoplastic straight running chains/ - Single hinge

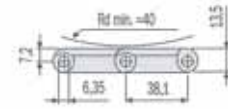
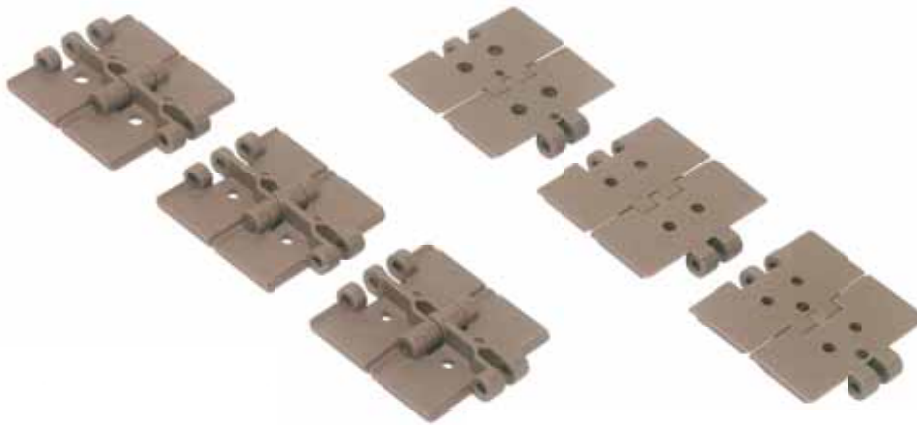

**820 Series  
Vacuum**

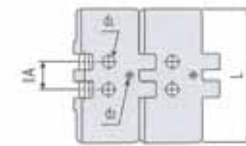
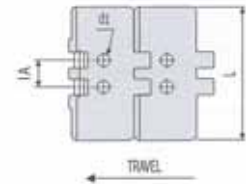

Chain Ref.	Material	Width L mm.	Ø Bore d1 mm.	Ø Bore d2 mm.	IA* mm.	Weight Kg./m.
<b>B2 Two bores</b>						
820 - K 325 B2	See page 2	82,5	6,5	-	19	0,83
820 - K 350 B2		88,9	4,0	-	45	0,87
820 - K 450 B2 H30		114,3	8,0	-	30	1,03
820 - K 450 B2 H50		114,3	8,0	-	50	1,03
<b>B2 Three bores</b>						
820 - K 325 B3		82,5	7,9	4,4	20	0,83

## Designation example

LFA — Mat + Colour  
820 — Chain type  
K 325 — Chain Width  
Vacum b2 — holes

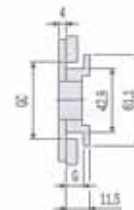
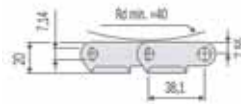

**880 TAB  
Series  
Vacuum**

Chain Ref.	Material	Width L mm.	Ø Bore d1 mm.	IA*	Min. Radius R mm.	GC Straight mm.	GC Sidefl. mm.	Weight Kg./m.
<b>B1 one bore</b>								
880 TAB - K 325 B1		82,5	5/6/6,5/8/9,5/10	-	457	46	44,2	0,94
<b>B2 two bore</b>								
880 TAB - K 335 B2	See page 2	82,5	6	24	457	46	44,2	0,94
		82,5	8	20	457	46	44,2	0,94
880 TAB - K 450 B2		114,3	6	24	610	46	44,2	1,08

\*IA = Distance between centres.

- Standard shipping lengths = 80 pitches = 10 feet = 3,048 metres.
- These chains can be supplied either with pins in austenitic stainless steel, work hardened, highly wear resistant or in thermoplastic resin.

# Straight running chains with thermoplastic Top Plates

## 843 Series

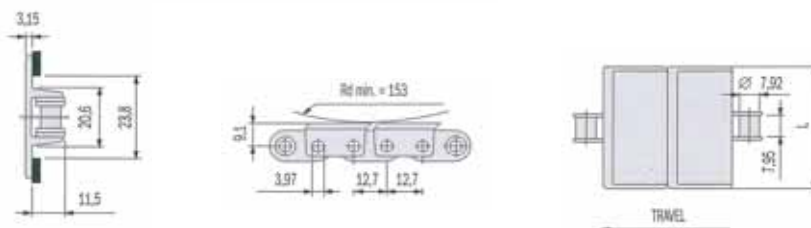

Chain Ref.	Material		Width L mm.	Weight Kg./m.
	Base chain	Top plate		
843 - K 138	Steel	See page 2	34,9	0,83
843 - K 144*			36,5	0,84
843 - K 200			50,8	0,89
843 - K 275*			70,0	0,92
843 - K 325*			82,5	1,03

Chain Ref.	Material		Width L mm.	Weight Kg./m.
	Base chain	Top plate		
843 SS - K 138	Stainless	See page 2	34,9	0,83
843 SS - K 144*			36,5	0,84
843 SS - K 200			50,8	0,89
843 SS - K 275*			70,0	0,92
843 SS - K 325*			82,5	1,03

## 845 Series



**Designation example**

LFA — Mat + Colour  
 845 — Chain type  
 K 118 — Chain Width

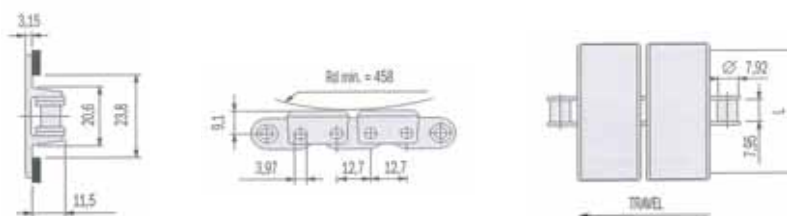

Chain Ref.	Material		Width L mm.	Weight Kg./m.
	Base chain	Top plate		
845 - K 118*	Steel	See page 2	28,6	0,85
845 - K 138			34,9	0,89
845 - K 200*			50,8	0,99

Chain Ref.	Material		Width L mm.	Weight Kg./m.
	Base chain	Top plate		
845 SS - K 118*	Stainless	See page 2	28,6	0,85
845 SS - K 138*			34,9	0,89
843 SS - K 200*			50,8	0,99

\*Size produced only upon request.  
 - Standard shipping lengths = 240 pitches = 10 feet = 3,048 metres.

Straight running chains with thermoplastic Top Plate

# Straight running chains with thermoplastic Top Plates

863 Series

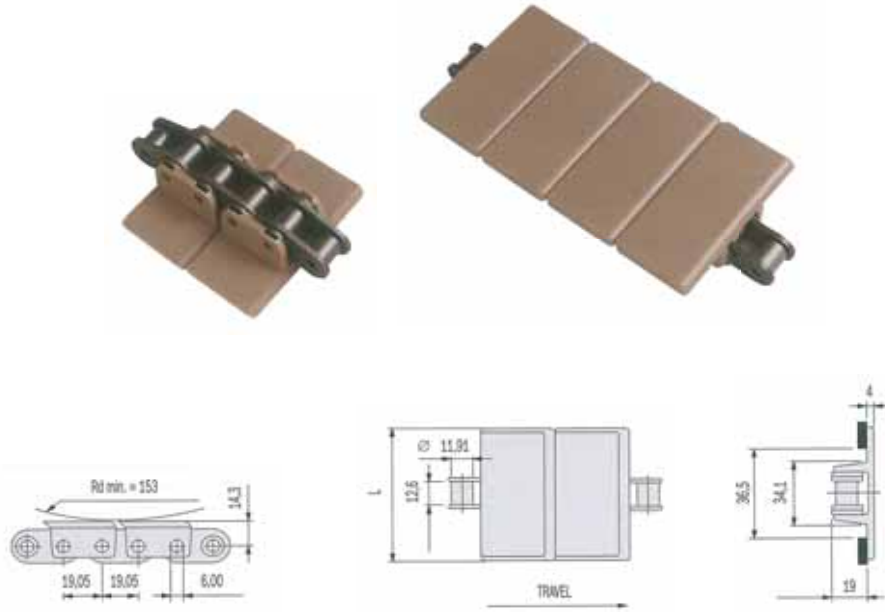

### Designation example

- LFA — Mat + Colour
- 863 — Chain type
- K 175 — Chain Width

Chain Ref.	Material		Width L mm.	Weight Kg./m.
	Base chain	Top plate		
863 - K 175*			44,5	1,9
863 - K 250			63,5	2,0
863 - K 325			82,5	2,1
863 - K 450	Steel	See page 2	114,3	2,3
863 - K 600*			152,4	2,5
863 - K 750			190,5	2,7

Chain Ref.	Material		Width L mm.	Weight Kg./m.
	Base chain	Top plate		
863 SS - K 175*			44,5	1,9
863 SS - K 250			63,5	2,0
863 SS - K 325	Stainless		82,5	2,1
863 SS - K 450	Steel	See page 3	114,3	2,3
863 SS - K 600*			152,4	2,5
863 SS - K 750			190,5	2,7

\*Size produced only upon request.  
 – Standard shipping lengths = 240 pitches = 10 feet = 3,048 metres.



## "1843" Sideflexing chains with thermoplastic Top Plates

### 1843 Series

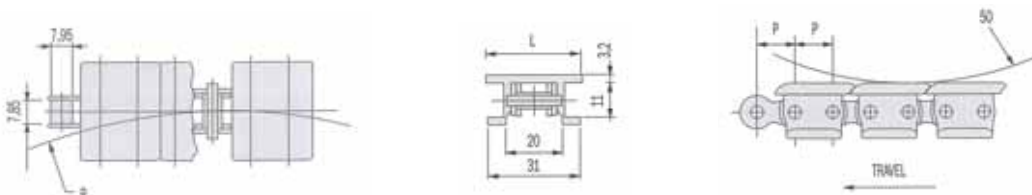

Chain Ref.	Material		Width L mm	Pitch P mm	Min. Radius R mm	Weight Kg/m
	Base chain	Top plate				
1843 TAB - K 125	Steel		31,80			0,74
1843 TAB - K 200	Steel		50,80			0,89
1843 TAB SS - K 125	Stainless Steel	See page 2	31,80	12,7	254	0,74
1843 TAB SS - K 200	Stainless Steel		50,80			0,89

## "1873" Sideflexing chains with thermoplastic Top Plates

### 1873 Series

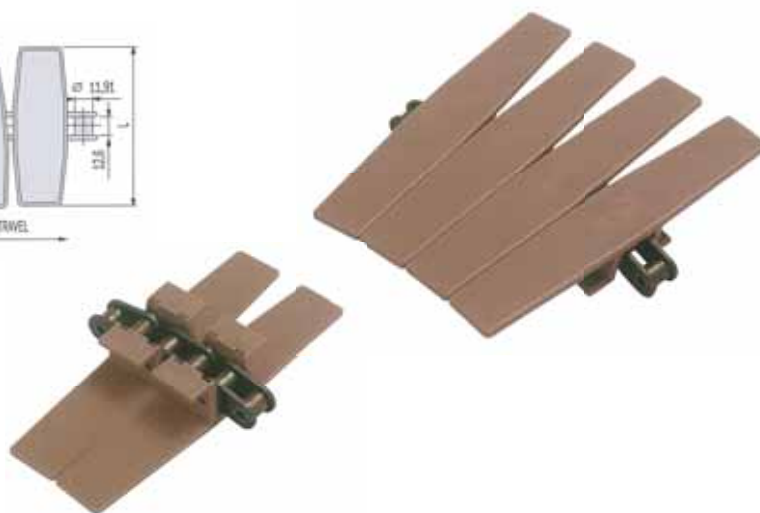
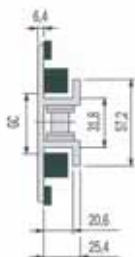
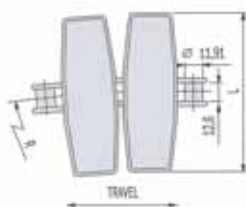
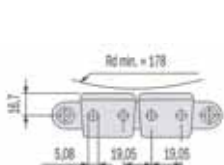

Chain Ref.	Material		Width L mm	Min. Radius R mm	GC Straight mm	GC Curve mm	Weight Kg/m
	Base chain	Top plate					
1873 TAB - K 325 / 1873 TAB SS - K 325	Steel / Stainless Steel		82,5	356			2,1
1873 TAB - K 450 / 1873 TAB SS - K 450	Steel / Stainless Steel		114,3	356			2,3
1873 TAB - K 600 / 1873 TAB SS - K 600	Steel / Stainless Steel	See page 2	152,4	457	33,3	34,6	2,4
1873 TAB - K 750 / 1873 TAB SS - K 750	Steel / Stainless Steel		190,5	457			2,6
1873 TAB - K 1000 / 1873 TAB SS - K 1000	Steel / Stainless Steel		254,0	457			2,8
1873 TAB - K 1200 / 1873 TAB SS - K 1200	Steel / Stainless Steel		304,8	610			3,0

- Standard shipping lengths = 80 pitches = 10 feet = 3,048 metres.

"1843" Sideflexing chains with thermoplastic Top Plate

# Thermoplastic straight running chains with rubber inserts – Single / Double hinge

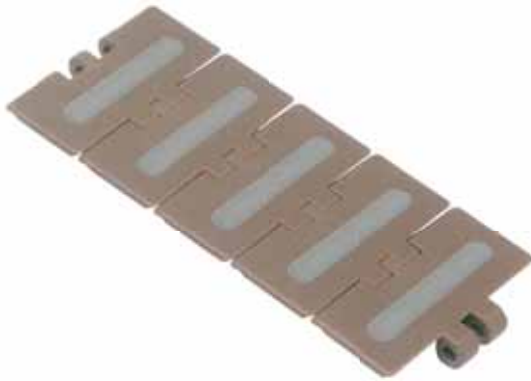

## HFL 820 Series

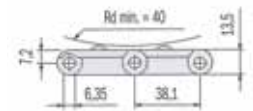
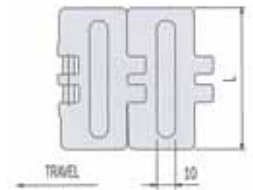
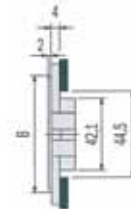

### High Friction Link

- Plates in self/lubricating acetal resin, light brown-coloured, with rubber inserts.
- Pins in special chrome-nickel stainless steel, work hardened for high resistance.

Chain Ref.	Material		L mm.	Width mm.	B mm.	Weight Kg/m
	Link	Antislip insert				
HFL 820 - K 325*	See page 2	Rubber 60 Shore A (Grey)	82,5	65,0	0,83	
HFL 820 - K 350*			88,9	88,9	0,87	
HFL 820 - K 400*			101,6	101,6	0,95	
HFL 820 - K 450*			114,3	114,3	1,03	
HFL 820 - K 600*			152,4	135,0	1,25	



## HFL 821 Series

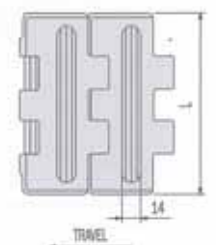
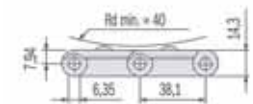
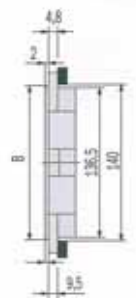

### High Friction Link

- Plates in self/lubricating acetal resin, light brown-coloured, with rubber inserts.
- Pins in special chrome-nickel stainless steel, work hardened for high resistance.

Chain Ref.	Material		L mm.	Width mm.	B mm.	Weight Kg/m
	Link	Antislip insert				
HFL 821 - K 750*	See page 2	Rubber 60 Shore A (Grey)	190,5	132,0	2,50	
HFL 821 - K 1000*			254,0	195,0	2,95	
HFL 821 - K 1200*			304,8	245,0	3,25	

\*Size produced only upon request.

– Standard shipping lengths = 80 pitches = 10 feet = 3,048 metres.

– Special configurations of distance between inserts are available upon request.

– These chains can be supplied with pins in austenitic stainless steel, work hardened, highly wear resistant, or with pins in thermoplastic resin.

# Thermoplastic sideflexing chains with rubber inserts

## HFL 880 TAB Series

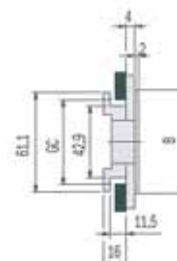
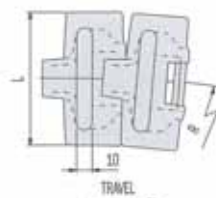
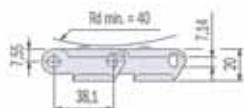

Chain Ref.	Material		L mm.	Width mm.	B mm.	Min. Radius R mm	GC Straight mm	GC Curve mm	Weight Kg/m
	Link	Antislip insert							
HFL 880 TAB - K 325*	See page 2	Rubber 60 Shore A	82,5	65	65	400	46	44,2	0,94
HFL 880 TAB - K 450*		(Grey)	114,3	95	400	46	44,2	1,08	

## HFL 880 BO Series

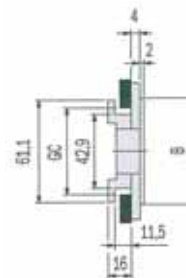
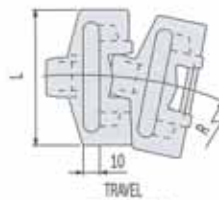
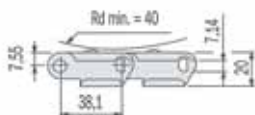

### Designation example

- HFL — Mat + Colour
- 880 — Chain type
- K 325 — Chain Width

Chain Ref.	Material		L mm.	Width mm.	B mm.	Min. Radius R mm	GC Straight mm	GC Curve mm	Weight Kg/m
	Link	Antislip insert							
HFL 880 BO - K 325*	See page 2	Rubber 60 Shore A (Grey)	82,5	65	65	190	46	44,2	0,96

- \*Size produced only upon request.
- Standard shipping lengths = 80 pitches = 10 feet = 3,048 metres.
- Special configurations of distance between inserts are available upon request.
- These chains can be supplied with pins in austenitic stainless steel, work hardened, highly wear resistant, or with pins in thermoplastic resin.



# Thermoplastic sideflexing chains with rubber inserts



**HFL 878  
BO Series**

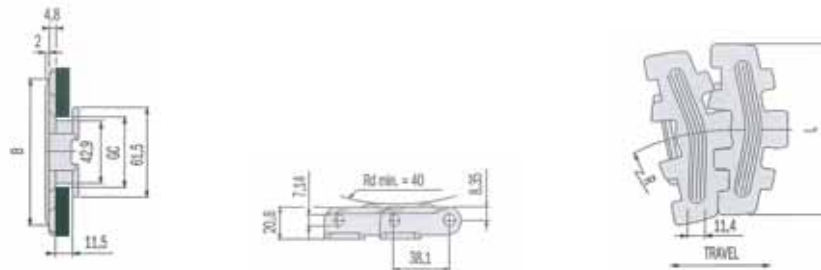

Chain Ref.	Material Link	Material Antislip insert	L mm.	Width mm.	B mm.	Min. Radius R mm	GC Straight mm	GC Curve mm	Weight Kg/m
HFL 878 BO - K 325 *	See page 2	Rubber 60 Shore A	82,5	71	71	190	46	44,2	1,08
HFL 878 BO - K 450*		(Grey)	114,3	102	102	190	46	44,2	1,20

**Designation example**  
HFL — Mat + Colour  
882 — Chain type  
K 750 — Chain Width



**HFL 878  
TAB Series**

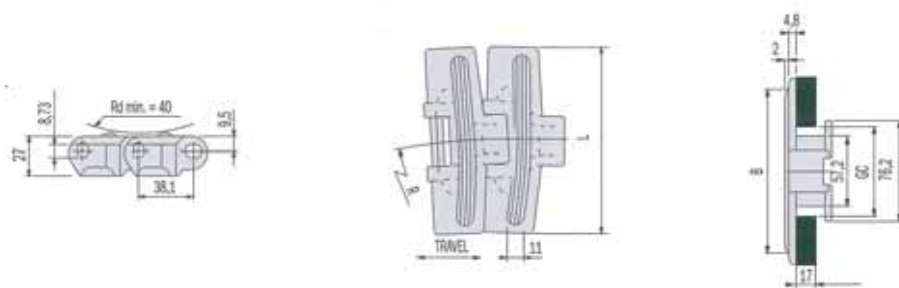

Chain Ref.	Material Link	Material Antislip insert	L mm.	Width mm.	B mm.	Min. Radius R mm	GC Straight mm	GC Curve mm	Weight Kg/m
HFL 882 TAB - K 750*	See page 2	Rubber 60 Shore A (Grey)	190,5	132	132	610	60	58	2,43
HFL 882 TAB - K 1000*			254,0	195	195				2,87
HFL 882 TAB - K 1200*			304,8	246	246				3,41

\*Size produced only upon request.  
- Standard shipping lengths = 80 pitches = 10 feet = 3,048 metres.  
- Special configurations of distance between inserts are available upon request.  
- These chains can be supplied with pins in austenitic stainless steel, work hardened, highly wear resistant, or with pins in thermoplastic resin.

Thermoplastic sideflexing chains with rubber inserts

# "1873" Sideflexing chains with themoplastic Top Plates and rubber inserts

**HFL 1873  
TAB Series**

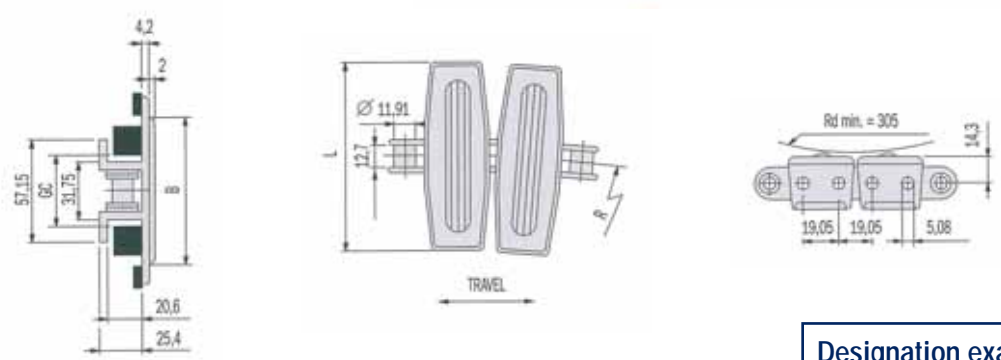
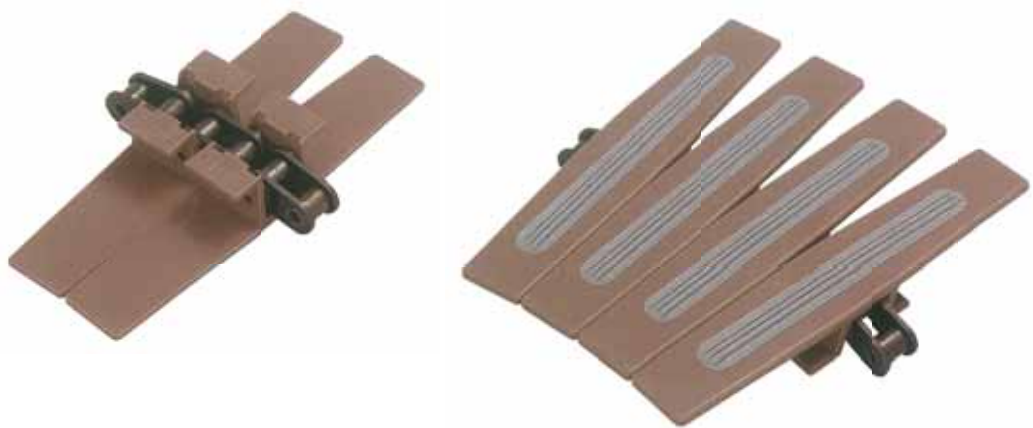

**Designation example**

HFL — Mat + Colour  
 1873 — Chain type  
 K 325 — Chain Width

Chain Ref.	Material		L mm.	Width mm.	B mm.	Min. Radius R mm	GC Straight mm	GC Curve mm	Weight Kg/m
	Base chain	Top Plate							
HFL 1873 TAB - K 325	Steel	See page 2	82,5	82,5	457	33,3	34,6		2,60
HFL 1873 TAB - K 350			88,9	88,9	457				2,65
HFL 1873 TAB - K 375			95,2	95,2	457				2,70
HFL 1873 TAB - K 450			114,3	114,3	457				2,80
HFL 1873 TAB - K 600			152,4	132	457				2,90
HFL 1873 TAB - K 750			190,5	132	457				3,10
HFL 1873 TAB - K 1000			254,0	195	457				3,40
HFL 1873 TAB - K 1200			304,8	245	610				3,60

HFL 1873 TAB SS - K 325	Stainless Steel	See page 2	82,5	82,5	457	33,3	34,6		2,60
HFL 1873 TAB SS - K 350			88,9	88,9	457				2,65
HFL 1873 TAB SS - K 375			95,2	95,2	457				2,70
HFL 1873 TAB SS - K 450			114,3	114,3	457				2,80
HFL 1873 TAB SS - K 600			152,4	132	457				2,90
HFL 1873 TAB SS - K 750			190,5	132	457				3,10
HFL 1873 TAB SS - K 1000			254,0	195	457				3,40
HFL 1873 TAB SS - K 1200			304,8	245	610				3,60

\*Size produced only upon request.  
 - Standard shipping lengths = 80 pitches = 10 feet = 3,048 metres.  
 - Special configurations of distance between inserts are available upon request.

"1873" Sideflexing chains with thermo-plastic Top Plates and rubber inserts

# Double hinge straight running chains - with low noise accumulation rollers

## Applications:

- Food and beverage industry packaging line (for ex. PET bottles in heat shrink film).
- General purpose conveying applications to reduce pressure created between product and flight surface.

## Advantages:

- High ultimate load.
- Rollers manufactured in low friction and low noise material: reduced back-line pressure and low noise level.
- Heavy duty.

## Characteristics:

This new series of thermoplastic chains is the solution to the pressure created between products and the conveying surface created by the accumulation of product. This is achieved by having a series of small width rollers which provides a stable conveying surface and enables the product to be handled without damage, however the chain still provides a positive forward motion and is based on our standard series LF821 / LF8257 / LF831 / LF882 chain.

### Designation example

- LBP — Mat + Colour  
821 — Chain type  
K 750 — Chain Width

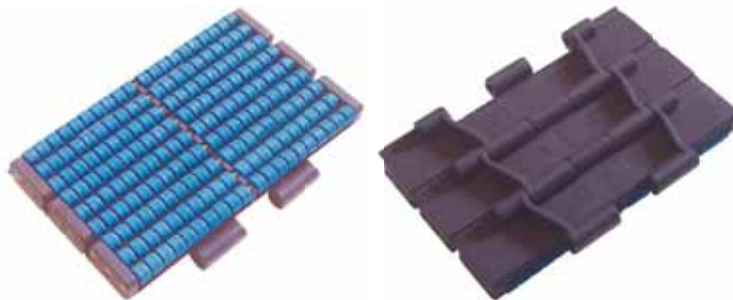

**LBP 821  
Series**

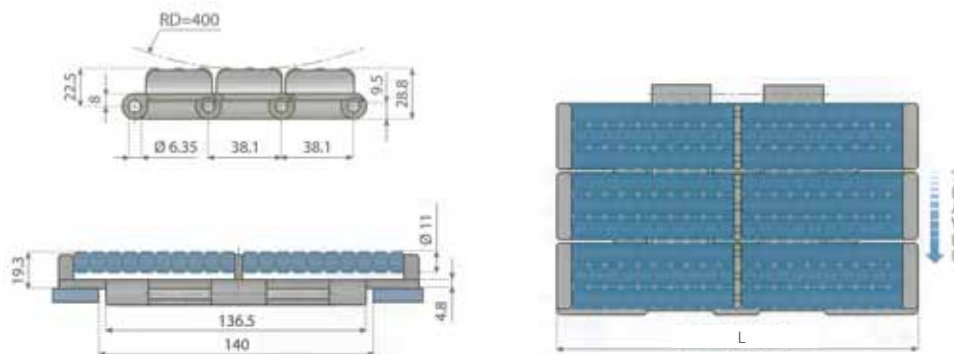

Chain Ref.	Material		Breaking Load N	Width L		Weight Kg/m
	Plate	Roller		mm.	inch.	
LBP 821 - K750	Dark Grey	Water Blue	8300	190,5	7.1/2	5.52
LBP 821 - K1000				254.0	10	6.90
LBP 821 - K1200				304.8	12	8.00

– Standard length: 40 pitches (5 Ft. - 1.524 m.)

# Straight running chains - Heavy duty single hinge - with low noise accumulation rollers

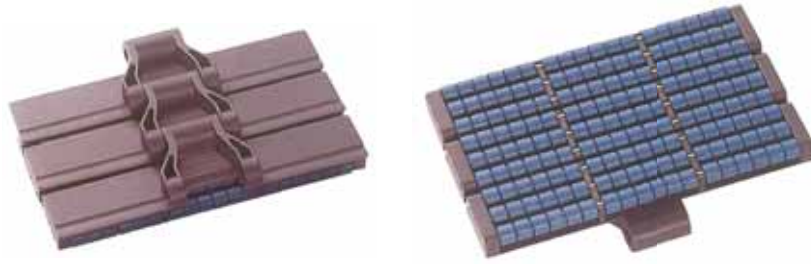

**LBP 8257 Series**

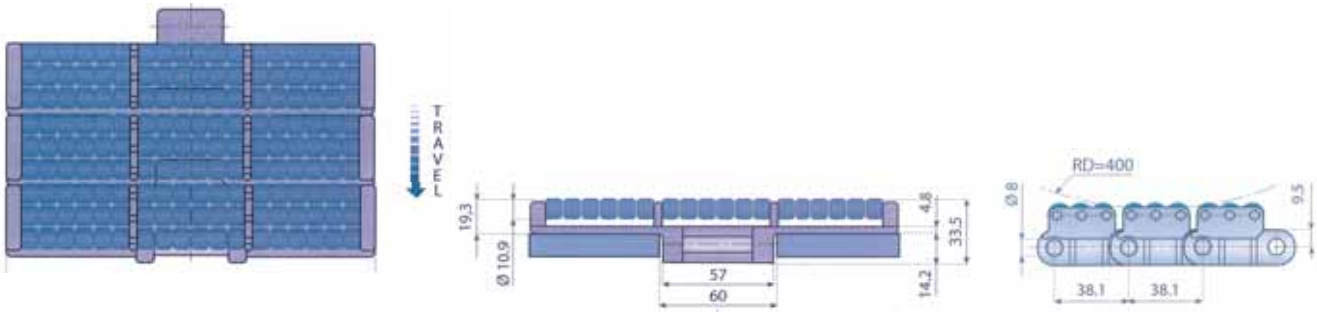

Chain Ref.	Material		Breaking Load N	Width L		Weight Kg/m
	Plate	Roller		mm.	inch.	
LBP 8257 - K750				190,5	7.1/2	5.65
LBP 8257 - K1000	Dark Grey	Water Blue	10000	254.0	10	7.20
LBP 8257 - K1200				304.8	12	8.10

**Designation example**

LBP — Mat + Colour  
 8257 — Chain type  
 K 750 — Chain Width

# Single hinge straight running chains - with low noise accumulation rollers

**LBP 831 Series**



**Designation example**

LBP — Mat + Colour  
 831 — Chain type  
 K 325 — Chain Width

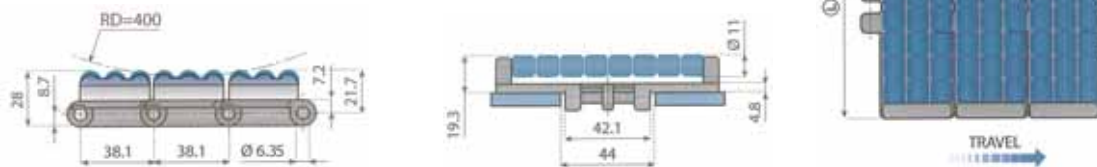

Chain Ref.	Material		Breaking Load N	Width L		Weight Kg/m
	Plate	Roller		mm.	inch.	
LBP 831 - K325				82,5	3.1/4	2.15
LBP 831 - K450	Dark Grey	Water Blue	5000	114.3	4.1/2	2.85

- Standard length: 40 pitches (5 Ft. - 1.524 m.).

Straight running chains - Heavy duty single hinge

# Sideflexing chains - with low noise accumulation rollers

**LBP 882  
TAB Series**

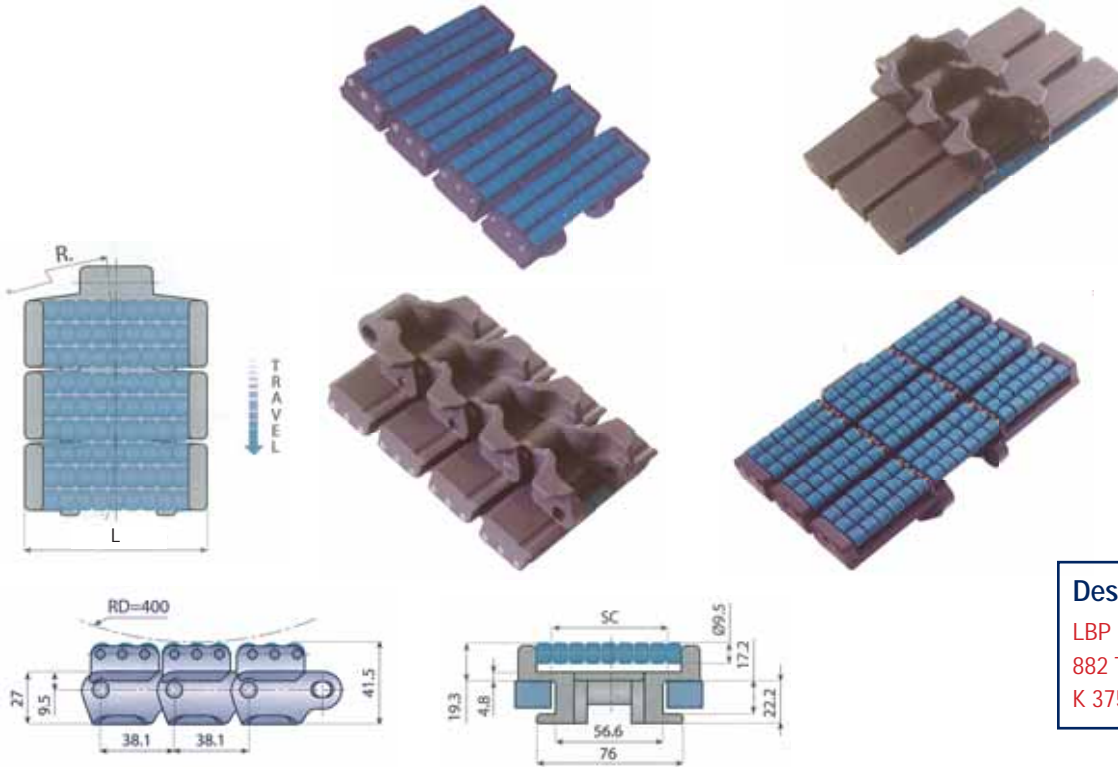

**Designation example**  
 LBP — Mat + Colour  
 882 TAB — Chain type  
 K 375 — Chain Width

Chain Ref.	Material		Breaking Load N	Width L		R. min.	SC		Weight Kg/m	
	Plate	Roller		mm.	inch.		Straight	Curving		
LBP 882 TAB - K375	LF Dark Grey	Water Blue	10000	95.3	3.3/4	610	60	58	3.31	
LBP 882 TAB - K450				114.3	4.1/2					4.03
LBP 882 TAB - K750				190.5	7.1/2					4.70
LBP 882 TAB - K1000				254	10					5.90
LBP 882 TAB - K1200				304.8	12					6.50

- Standard length: 40 pitches (5 Ft. - 1.524 m.)

# Flex thermoplastic chains

**1700  
Series**

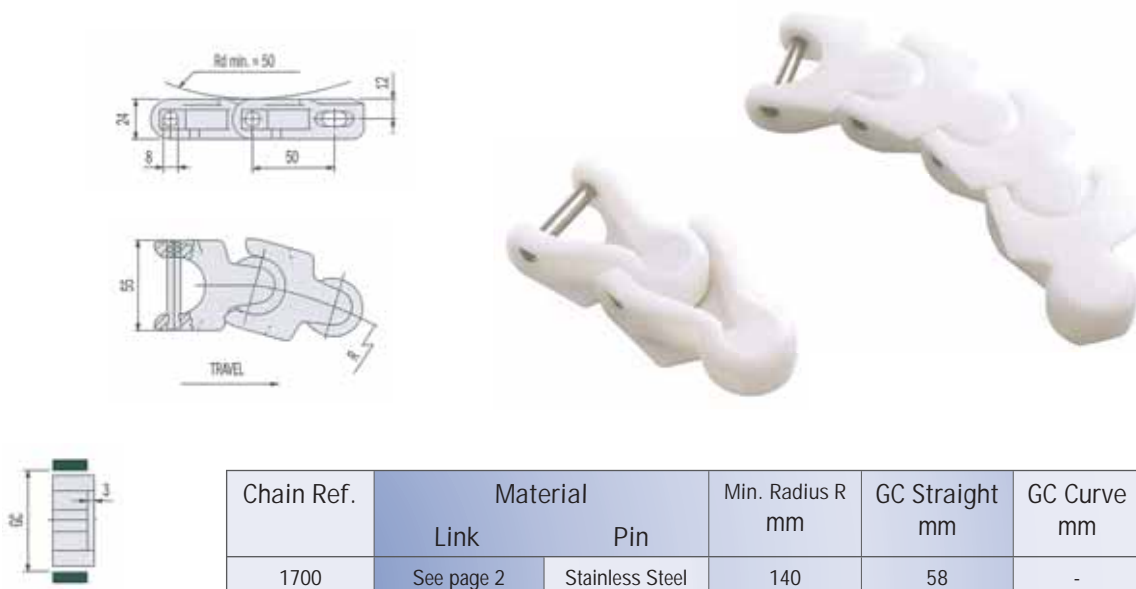

Chain Ref.	Material		Min. Radius R mm	GC Straight mm	GC Curve mm	Weight Kg/m
	Link	Pin				
1700	See page 2	Stainless Steel	140	58	-	1,26

Single hinge straight running chains  
- with low noise accumulation rollers

# Flex thermoplastic chains

## 1701 TAB Series

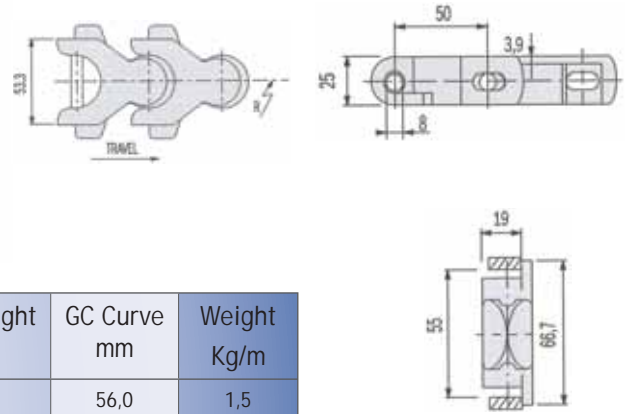

Chain Ref.	Material		Min. Radius R mm	GC Straight mm	GC Curve mm	Weight Kg/m
	Link	Pin				
1701 TAB	See page 2	Stainless Steel	150	57,5	56,0	1,5

## 1702 Series

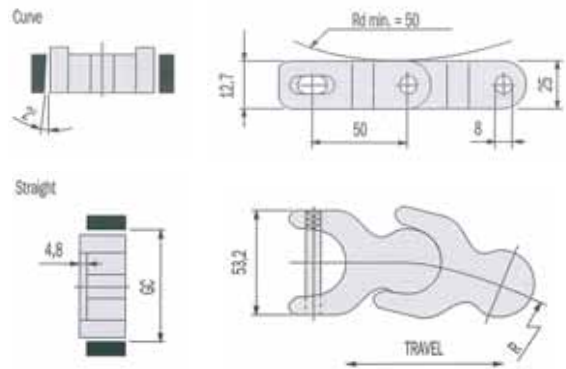

Chain Ref.	Material		Min. Radius R mm	GC Straight mm	GC Curve mm	Weight Kg/m
	Link	Pin				
1702	See page 2	Stainless Steel	140	59,5	56,8	1,43

**Designation example**  
 LFW — Mat + Colour  
 1700 — Chain type

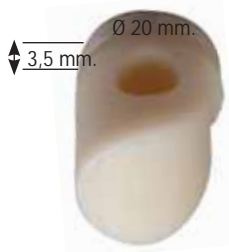
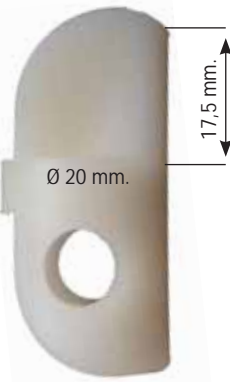
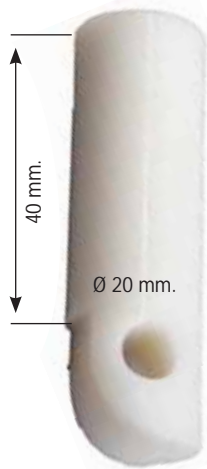

# Case conveyor chains

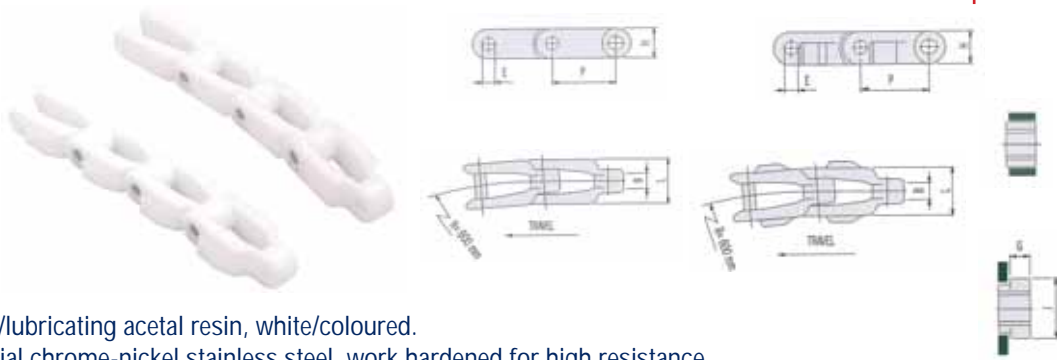

**CC 600 Series**

### Acetal Resin

- Links in self/lubricating acetal resin, white/coloured.
- Pins in special chrome-nickel stainless steel, work hardened for high resistance.

Chain Ref.	Material	Pitch P	Width L mm.	Pin Diameter E mm.	Max Sprocket Face B mm.	Depth of sidebar H mm.	Width Over Lug J mm.	Height Over Lug G mm.	Weight Kg./m.
CC 600	Acetal	63,5	43	11	14,3	29	-	-	1,44
CC 600 TAB	Acetal	63,5	43	11	14,3	29	54	15	1,49

- Standard shipping lengths = 61 pitches = 10 feet = 3,05 metres.
- Special configurations of distance between inserts are available upon request.

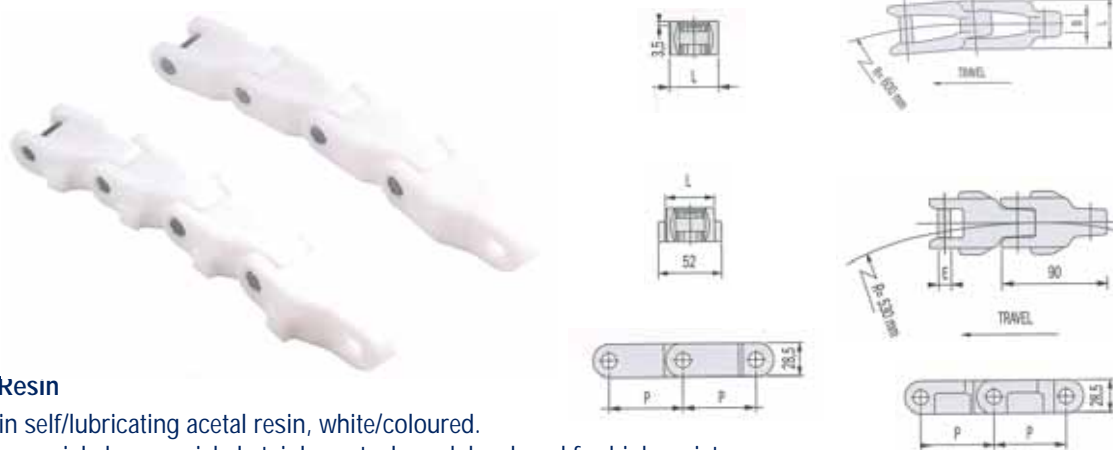

**CC 600 C Series**

### Acetal Resin

- Links in self/lubricating acetal resin, white/coloured.
- Pins in special chrome-nickel stainless steel, work hardened for high resistance.

Chain Ref.	Material	Pitch P	Width L mm.	Pin Diameter E mm.	Max Sprocket Face B mm.	Depth of sidebar H mm.	Width Over Lug J mm.	Height Over Lug G mm.	Weight Kg./m.
CC 600 C	Acetal	63,5	43	11	14,3	29	-	-	1,42
CC 600 C TAB	Acetal	63,5	43	11	14,3	29	52	15	1,55

- Standard shipping lengths = 48 pitches = 10 feet = 3,048 metres.



**CC 1400 Series**

### Acetal Resin

- Links in self/lubricating acetal resin, white/coloured.
- Pins in special chrome-nickel stainless steel, work hardened for high resistance.

Chain Ref.	Material	Pitch P	Width L mm.	Pin Diameter E mm.	Max Sprocket Face B mm.	Depth of sidebar H mm.	Width Over Lug J mm.	Height Over Lug G mm.	Weight Kg./m.
CC 1400	Acetal	82,5	50	9,5	15,9	38	-	-	1,44
CC 1400 TAB	Acetal	82,5	50	9,5	15,9	38	66	19	2,26

- Standard shipping lengths = 74 pitches = 20 feet = 6,105 metres.

CHEMICAL AGENT	Acetal Resin D	Acetal Resin LFA/WLF	Acetal Resin SP	Special Acetal Resin WR	Antistatic Resin AS	Polypropylene PPB
Acetic acid	0	0	0	••	0	••
Acetone	•	•	•	••	•	••
Aluminium chloride	0	0	0	••	0	0
Ammonia	••	••	••	••	••	••
Ammonium chloride	0	0	0	••	0	0
Amyl alcohol	0	0	0	••	0	••
Aniline	••	••	••	•	••	••
Beer	••	••	••	••	••	••
Benzene	••	••	••	••	••	••
Benzoic acid	0	0	0	•	0	••
Benzol	••	••	••	••	••	•
Boric acid	••	••	••	••	••	••
Brine	•	•	•	•	•	••
Butter	••	••	••	••	••	••
Butyl alcohol	0	0	0	••	0	••
Butyric acid	0	0	0	0	0	••
Calcium chloride	•	•	•	••	•	••
Carbon disulphide	••	••	••	••	••	••
Carbon tetrachloride	••	••	••	••	••	0
Caustic soda (20 %)	0	0	0	••	0	••
Cheese	••	••	••	0	••	••
Chlorine water	0	0	0	••	0	0
Chloroform	0	0	0	0	0	•
Citric acid	•	•	•	•	•	••
Copper sulphate	••	••	••	••	••	••
Diet oil	••	••	••	••	••	••
Diet fat	••	••	••	••	••	••
Distilled water	••	••	••	••	••	••
Ethyl acetate	0	0	0	••	0	••
Ethyl alcohol	••	••	••	••	••	••
Ethyl chloride	••	••	••	••	••	0
Ethyl ether	••	••	••	••	••	••
Flax oil	0	0	0	••	0	••
Formaldehyde	••	••	••	••	••	••
Formic acid	0	0	0	0	0	••
Freon 12	0	0	0	••	0	0
Fresh water	••	••	••	••	••	••
Fruit juice	••	••	••	••	••	••
Gasoline	••	••	••	••	••	•
Glycerin	••	••	••	••	••	••
Hydrochloric acid	0	0	0	0	0	••
Hydrofluoric acid	0	0	0	0	0	••
Hydrogen peroxide	0	0	0	0	0	••
Iodine	••	••	••	0	••	••
Iron chloride	0	0	0	••	0	••
Lactic acid	••	••	••	••	••	••
Magnesium chloride	0	0	0	••	0	••
Mercury	••	••	••	••	••	••
Methyl alcohol	••	••	••	••	••	••
Methylene chloride	0	0	0	••	0	•
Milk	••	••	••	••	••	••
Nitric acid	0	0	0	0	0	••
Oil	••	••	••	••	••	•
Oil ether	••	••	••	••	••	••
Oleic acid	0	0	0	••	0	••
Paraffin	••	••	••	0	••	•
Phenol	0	0	0	0	0	••
Phosphoric acid	0	0	0	••	0	••
Potassium hydroxide	0	0	0	••	0	0
Sea water	•	•	•	••	•	••
Silicon oil	0	0	0	••	0	••
Silver nitrate	0	0	0	••	0	••
Soapy water	••	••	••	••	••	••
Sodium carbonate	••	••	••	••	••	••
Sodium chloride	••	••	••	••	••	••
Sodium hydroxide	••	••	••	••	••	••
Sodium hypochlorite	0	0	0	••	0	••
Sodium silicate	0	0	0	••	0	0
Sodium sulphate	••	••	••	••	••	••
Soft drinks	••	••	••	••	••	••
Suds	0	0	0	••	0	••
Sulphuric acid	0	0	0	0	0	••
Tartaric acid	•	•	•	••	•	••
Tetraline	0	0	0	••	0	0
Tincture of iodine	••	••	••	0	••	••
Transformer oil	0	0	0	••	0	•
Trichloroethylene	0	0	0	•	0	•
Turpentine	0	0	0	•	0	0
Vegetable juice	••	••	••	••	••	••
Vegetable oil	••	••	••	••	••	••
Vinegar	••	••	••	••	••	••
Whisky	••	••	••	••	••	••
Wine	••	••	••	••	••	••
Xilol	••	••	••	••	••	0
Zinc chloride	0	0	0	•	0	••



Among our broad product range you will also find a vast selection of high-quality metal conveyor chains available in carbon steel, stainless steel and naturally in different sizes. Due to the many different surfaces and grades of hardness in which these chains can be supplied, the varieties of applications are endless. This enables us to offer high-speed, high wear or low noise chains etc. for curves, magnetic curves, straight running or even inclined/declined conveyors.



The chains are produced with high quality steel / stainless steel in order to satisfy the growing needs of technological progress on the conveying lines.

## SLATS

### Hard Inox

Special work hardened chrome-nickel, highly wear corrosion resistant stainless steel. It offers excellent mechanical characteristics and exceptional sliding properties, thanks to a very low surface roughness.

It is particularly suitable for the critical points of bottling lines.

Material used for the following chain models: Super, Flex RXMS, Flex FMS, Flex FMS2, New Flex Mag, Super-G, Flex RXMS-G and New Flex Mag-G.

### Inox

Ferritic, AISI 430 stainless steel, work hardened by cold-rolling, with good corrosion resistance. It has an excellent surface finishing with a low roughness, that is very important quality for the sliding of conveyed products. It is the preferred choice for standard bottling industry applications.

Material used for the following chain models: Special, Standard and Flex RXMC.

### HQ Inox (High Quality)

Special, new, chrome-nickel (W.1.4589) stainless steel, work hardened. It has been developed in cooperation with a major stainless steel manufacturer for very special applications such as pressureless combiners/inliners. Cold rolled to extremely high quality standards, this material is the right answer to the most sophisticated needs. Its exceptional surface finishing and flatness together with a very high working load and wear resistance are unique features.

Material used for the following chain models: Superspeed, Wear-Proof, Flex FMD and New Flex Mag-D.

### Inox 18/8

Austenitic, non-magnetic AISI 304 stainless steel (18% Chrome - 8% Nickel), work hardened for high resistance. It provides excellent resistance to chemical agents and corrosion, and offers excellent mechanical and duration characteristics. It is mainly used in the preservation and bottling industry. Approved by Food and Drug Administration (FDA), American government institute for the direct contact with foodstuff.

Material used for the following chain models: Stella D, Flex RXM, Flex FM and Flex FM2.

### Inox 316

Austenitic, non-magnetic AISI 316 stainless steel (18% Chrome - 14% Nickel - 3% Molybdenum). It is ideal with chemical agents and strong acids. Material used for the following chain models: 316 and Flex RXM 316.

### Carbon Steel

Heat-treated carbon steel with a surface and core hardness of 43 HRC. It is especially suitable for high working loads and it is highly resistant to wear. It is recommended for the glass, ceramic and general product conveying industry. In case of difficult applications, such as with abrasive dust, the carbon steel can be, upon request, case hardened, thus reaching a surface hardness of 55 HRC and a core hardness of 40 HRC.

Material used for the following chain models: Accate and Flex RXMA.

Materials	Minimum temperatures	Maximum temperatures	
		Dry env.	Wet env.
Inox	- 40°C	+ 260°C	+ 120°C
Hard Inox	- 40°C	+ 400°C	+ 120°C
HQ Inox	- 40°C	+ 430°C	+ 120°C
Inox 18/8	- 40°C	+ 400°C	+ 120°C
Inox 316	- 40°C	+ 400°C	+ 120°C
Carbon Steel	- 40°C	+ 180°C	+ 120°C

812 Series

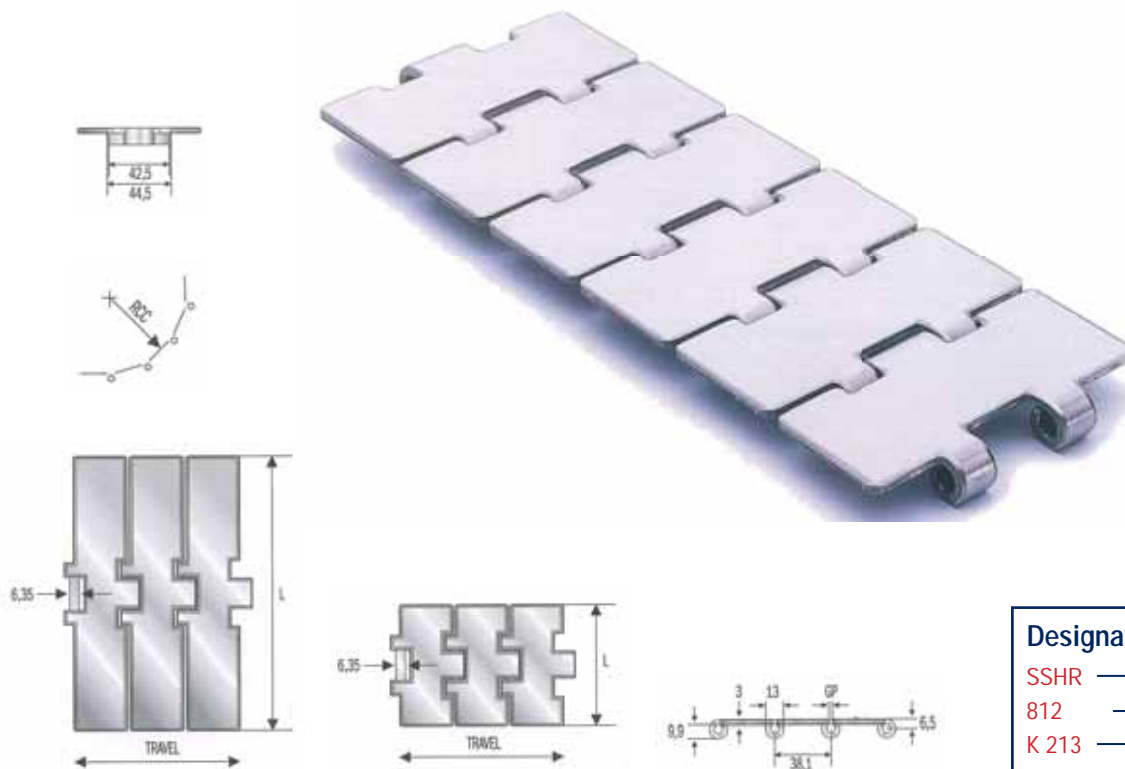

### Designation example

SSHR — Material  
812 — Chain type  
K 213 — Chain Width

### SUPER - Hard Inox

- Special, chrome-nickel, stainless steel slats, work hardened for high resistance, with shiny surface having a roughness of  $Ra \leq 0.3$  microns.
- AISI 431 stainless steel pins, magnetic and work hardened for high resistance.

Chain Ref.	Model	L=Slat width		Hardness HRC	GP mm.	RCC mm.	Weight per metre Kg./m.
		mm.	"				
SSHR 812 - K 213	Super	54,1	-	30	2,8	75	2,10
SSHR 812 - K 250	Super	63,5	2 1/2	30	2,8	75	2,20
SSHR 812 - K 263	Super	66,7	2 5/8	30	2,8	75	2,30
SSHR 812 - K 300	Super	76,2	3	30	2,8	75	2,45
SSHR 812 - K 325	Super	82,5	3 1/4	30	2,8	75	2,60
SSHR 812 - K 335	Super	85,0	-	30	2,8	75	2,68
SSHR 812 - K 350	Super	88,9	3 1/2	30	2,8	75	2,70
SSHR 812 - K 500	Super	127,0	5	30	2,8	75	3,50

SSH 812 - K 225	Super	57,1	2 1/4	30	1,6	150	2,18
SSH 812 - K 250	Super	63,5	2 1/2	30	1,6	150	2,25
SSH 812 - K 275	Super	69,9	2 3/4	30	1,6	150	2,35
SSH 812 - K 300	Super	76,2	3	30	1,6	150	2,50
SSH 812 - K 325	Super	82,5	3 1/4	30	1,6	150	2,65
SSH 812 - K 375	Super	95,3	3 3/4	30	1,6	150	2,85
SSH 812 - K 400	Super	101,6	4	30	1,6	150	3,00
SSH 812 - K 450	Super	114,3	4 1/2	30	1,6	150	3,30
SSH 812 - K 600	Super	152,4	6	30	1,6	150	4,20
SSH 812 - K 750	Super	190,5	7 1/2	30	1,6	150	5,10

- Standard shipping lengths = 80 pitches = 10 feet = 3,048 metres.

# Straight running chains

## - Single hinge

### SUPER SPEED - HQ Inox

- Special, new stainless steel, chrome-nickel (W.1.4589) slats, work hardened for high resistance with very little roughness of  $Ra \leq 0.18$  microns.
- Special stainless steel pins, magnetic and heat treated for high speed systems.

The chain is produced with a special profile: thanks to its perfect levelness and shiny surface, it is particularly suitable for pressureless combiners/inliners and high speed systems.

**812 Series**

Chain Ref.	Model	L=Slat width		Hardness	GP	RCC	Weight per metre
		mm.	"	HRC	mm.	mm.	Kg./m.
SSX 812 - K 325	Superspeed	82,5	3 1/4	30	1,6	150	2,60

### WEAR-PROOF - HQ Inox

- Special, new stainless steel, chrome-nickel (W.1.4589) slats, work hardened for high resistance with very little roughness of  $Ra \leq 0.2$  microns.
- Special stainless steel pins, magnetic and heat treated for high resistance.

Chain Ref.	Model	L=Slat width		Hardness	GP	RCC	Weight per metre
		mm.	"	HRC	mm.	mm.	Kg./m.
SSHQR 812 - K 325	Wear-Proof	82,5	3 1/4	30	2,8	75	2,60

SSHQ 812 - K 325	Wear-Proof	82,5	3 1/4	30	1,6	150	2,65
------------------	------------	------	-------	----	-----	-----	------

### STANDARD - Inox

- Ferritic, AISI 430 stainless steel slats, work hardened, with shiny surface having low roughness.
- AISI 431 stainless steel pins, magnetic and work hardened for high resistance.

Chain Ref.	Model	L=Slat width		Hardness	GP	RCC	Weight per metre
		mm.	"	HRC	mm.	mm.	Kg./m.
SSR 812 - K 213	Standard	54,1	-	20	2,8	75	2,10
SSR 812 - K 250	Standard	63,5	2 1/2	20	2,8	75	2,20
SSR 812 - K 263	Standard	66,7	2 5/8	20	2,8	75	2,30
SSR 812 - K 300	Standard	76,2	3	20	2,8	75	2,45
SSR 812 - K 335	Standard	85,0	-	20	2,8	75	2,68
SSR 812 - K 350	Standard	88,9	3 1/2	20	2,8	75	2,70

SS 812 - K 225	Standard	57,1	2 1/4	20	1,6	150	2,18
SS 812 - K 250	Standard	63,5	2 1/2	20	1,6	150	2,25
SS 812 - K 275	Standard	69,9	2 3/4	20	1,6	150	2,35
SS 812 - K 300	Standard	76,2	3	20	1,6	150	2,50
SS 812 - K 325	Standard	82,5	3 1/4	20	1,6	150	2,65
SS 812 - K 400	Standard	101,6	4	20	1,6	150	3,00
SS 812 - K 450	Standard	114,3	4 1/2	20	1,6	150	3,30
SS 812 - K 600	Standard	152,4	6	20	1,6	150	4,20
SS 812 - K 750	Standard	190,5	7 1/2	20	1,6	150	5,10

- Standard shipping lengths = 80 pitches = 10 feet = 3,048 metres.

# Straight running chains

## - Single hinge

### SPECIAL - Inox

- Ferritic, AISI 430 stainless steel slats, work hardened, with shiny surface having low roughness.
- AISI 431 stainless steel pins, magnetic and work hardened for high resistance.



812  
Series

Chain Ref.	Model	L=Slat width		Hardness	GP	RCC	Weight per metre
		mm.	"	HRC	mm.	mm.	Kg./m.
SSR 812 - K 325	Special	82,5	3 1/4	20	2,8	75	2,55

### STELLA D - Inox 18/8

- Chrome-nickel, austenitic AISI 304 stainless steel slats (18% Chrome - 8% Nickel), work hardened for high resistance - with a roughness of  $Ra \leq 0.5$  microns.
- Austenitic stainless steel pins (18% Chrome - 8% Nickel), work hardened for high resistance.

815  
Series

Chain Ref.	Model	L=Slat width		Hardness	GP	RCC	Weight per metre
		mm.	"	HRC	mm.	mm.	Kg./m.
SSAR 815 - K 213*	Stella D	54,1	-	26	2,8	75	2,10
SSAR 815 - K 250	Stella D	63,5	2 1/2	26	2,8	75	2,20
SSAR 815 - K 263	Stella D	66,7	2 5/8	26	2,8	75	2,30
SSAR 815 - K 300	Stella D	76,2	3	26	2,8	75	2,45
SSAR 815 - K 325	Stella D	82,5	3 1/4	26	2,8	75	2,60
SSAR 815 - K 335*	Stella D	85,0	-	26	2,8	75	2,68
SSAR 815 - K 350	Stella D	88,9	3 1/2	26	2,8	75	2,70
SSAR 815 - K 500	Stella D	127,0	5	26	2,8	75	3,50

SSA 815 - K 225	Stella D	57,1	2 1/4	26	1,6	150	2,18
SSA 815 - K 250	Stella D	63,5	2 1/2	26	1,6	150	2,25
SSA 815 - K 275	Stella D	69,9	2 3/4	26	1,6	150	2,35
SSA 815 - K 300	Stella D	76,2	3	26	1,6	150	2,50
SSA 815 - K 325	Stella D	82,5	3 1/4	26	1,6	150	2,65
SSA 815 - K 375	Stella D	95,3	3 3/4	26	1,6	150	2,85
SSA 815 - K 400	Stella D	101,6	4	26	1,6	150	3,00
SSA 815 - K 450	Stella D	114,3	4 1/2	26	1,6	150	3,30
SSA 815 - K 600	Stella D	152,4	6	26	1,6	150	4,20
SSA 815 - K 750	Stella D	190,5	7 1/2	26	1,6	150	5,10

### 316 - Inox 316

- Chrome-nickel, austenitic AISI 316L stainless steel slats (18% Chrome - 14% Nickel - 3% Molybdenum).
- Austenitic AISI 316 stainless steel pins.

Chain Ref.	Model	L=Slat width		Hardness	GP	RCC	Weight per metre
		mm.	"	HRC	mm.	mm.	Kg./m.
SSAA 815 - K 325*	316	82,5	3 1/4	-	1,6	150	2,65
SSAA 815 - K 450*	316	114,3	4 1/2	-	1,6	150	3,30
SSAA 815 - K 600*	316	152,4	6	-	1,6	150	4,20
SSAA 815 - K 750*	316	190,5	7 1/2	-	1,6	150	5,10

\*Size produced only upon request.

- Standard shipping lengths = 80 pitches = 10 feet = 3,048 metres.

# Straight running chains

## - Single hinge

### ACCATE - Carbon Steel

- Heat-treated carbon steel slats.
- Case hardened carbon steel pins.



815 Series

#### Designation example

- S — Material
- 815 — Chain type
- K 225 — Chain Width

Chain Ref.	Model	L=Slat width		Core Hardness	Surface Hardness	GP	RCC	Weight per metre
		mm.	"	HRC	HRC	mm.	mm.	Kg./m.
S 815 - K 225	Accate	57,1	2 1/4	43	43	1,6	150	2,15
S 815 - K 250	Accate	63,5	2 1/2	43	43	1,6	150	2,22
S 815 - K 300	Accate	76,2	3	43	43	1,6	150	2,50
S 815 - K 325	Accate	82,5	3 1/4	43	43	1,6	150	2,65
S 815 - K 400	Accate	101,6	4	43	43	1,6	150	3,00
S 815 - K 450	Accate	114,3	4 1/2	43	43	1,6	150	3,30
S 815 - K 473*	Accate	120,0	-	43	43	1,6	150	3,45
S 815 - K 600	Accate	152,4	6	43	43	1,6	150	4,20
S 815 - K 750	Accate	190,5	7 1/2	43	43	1,6	150	5,10

# "Mignon" straight running chains

## - Single hinge

812 Mini Series

### STANDARD - Inox

- Ferritic, AISI 430 stainless steel slats, work hardened, with shiny surface having low roughness.
- AISI 431 stainless steel pins, magnetic and work hardened for high resistance.

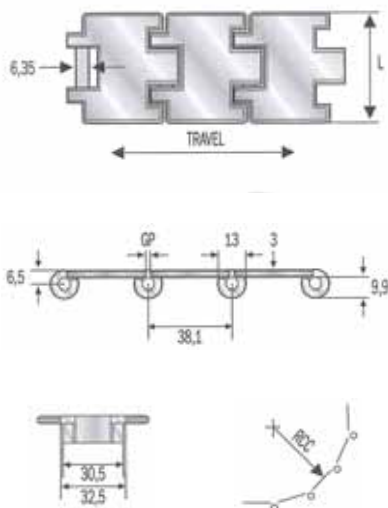

"Mignon" straight running chains - Single hinge

# "Mignon" straight running chains

## - Single hinge

812 Mini Series

### STELLA D - Inox 18/8

- Chrome-nickel, austenitic AISI 304 stainless steel slats (18% Chrome - 8% Nickel), work hardened for high resistance - shiny - with a roughness of  $Ra \leq 0.5$  microns.
- Austenitic stainless steel pins (18% Chrome - 8% Nickel), work hardened for high resistance.

Chain Ref.	Model	L=Slat width		Hardness	GP	RCC	Weight per metre
		mm.	"	HRC	mm.	mm.	Kg./m.
SSR 812 - K 197	Standard	50,0	-	20	2,5	90	1,60
SSAR 812 - K 197	Stella D	50,0	-	26	2,5	90	1,60

### SUPER - Hard Inox

- Special, chrome-nickel stainless steel slats, work hardened for high resistance - shiny - with shiny surface having a roughness of  $Ra \leq 0.3$  microns.
- AISI 431 stainless steel pins, magnetic and work hardened for high resistance.

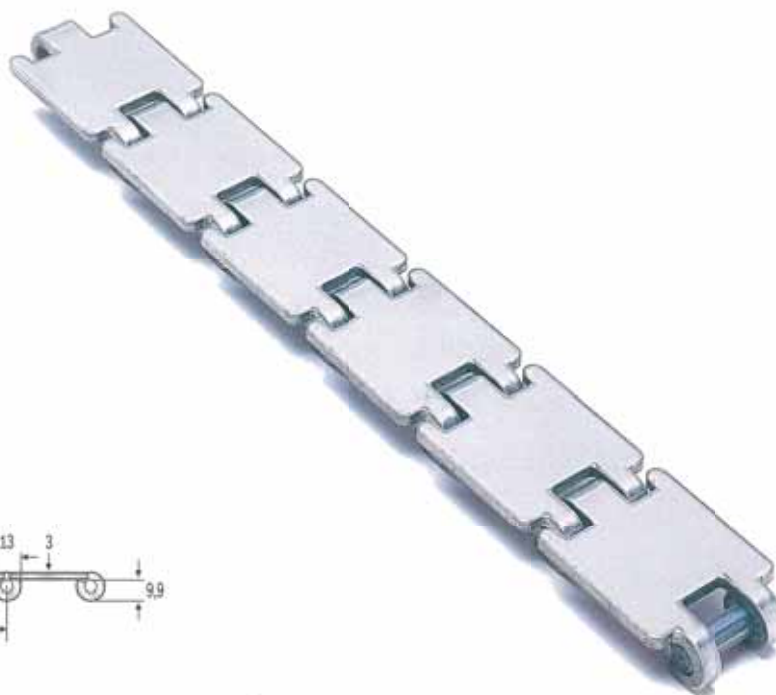

**Designation example**

SSAR — Material  
 812 — Chain type  
 K 197 — Chain Width

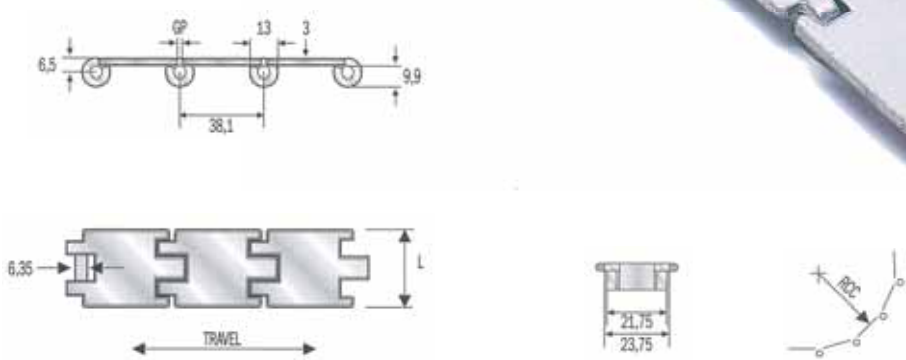

Chain Ref.	Model	L=Slat width		Hardness	GP	RCC	Weight per metre
		mm.	"	HRC	mm.	mm.	Kg./m.
SSHR 812 - K 125	Super	31,8	1 1/4	30	2,8	75	1,10
SSHR 812 - K 175	Super	44,5	1 3/4	30	2,8	75	1,30

- Standard shipping lengths = 80 pitches = 10 feet = 3,048 metres.

"Mignon" straight running chains - Single hinge

# Straight running chains

## - Double hinge

**802 Series**

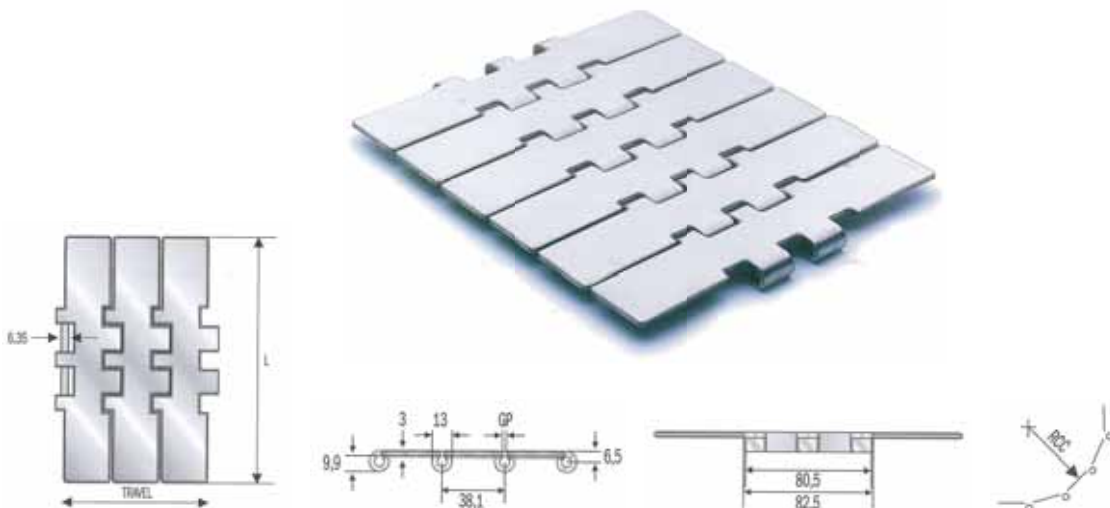

### STANDARD - Inox

- Ferritic, AISI 430 stainless steel slats, work hardened, with shiny surface having low roughness.
- AISI 431 stainless steel pins, magnetic and work hardened for high resistance.

### SUPER - Hard Inox

- Special, chrome-nickel stainless steel slats, work hardened for high resistance - shiny - with shiny surface having a roughness of  $Ra \leq 0.3$  microns.
- AISI 431 stainless steel pins, magnetic and work hardened for high resistance.

### STELLA D - Inox 18/8

- Chrome-nickel, austenitic AISI 304 stainless steel slats (18% Chrome - 8% Nickel), work hardened for high resistance - shiny - with a roughness of  $Ra \leq 0.5$  microns.
- Austenitic stainless steel pins (18% Chrome - 8% Nickel), work hardened for high resistance.

Chain Ref.	Model	L=Slat width		Hardness	GP	RCC	Weight per metre
		mm.	"				
SS 802 - K 750	Standard	190,5	7 1/2	20	1,6	150	5,80

SSH 802 - K 750	Super	190,5	7 1/2	30	1,6	150	5,80
-----------------	-------	-------	-------	----	-----	-----	------

SSA 805 - K 750	Stella D	190,5	7 1/2	26	1,6	150	5,80
-----------------	----------	-------	-------	----	-----	-----	------

Siderflexing hinged slat chains

### ACCATE - Carbon Steel

- Heat-treated carbon steel slats, with a surface and core of 43 HRC.
- Case hardened carbon steel pins.



**Designation example**

SS — Material

802 — Chain type

K 750 — Chain Width

Chain Ref.	Model	L=Slat width		Hardness	GP	RCC	Weight per metre
		mm.	"				
S 802 - K 750	Accate	190,5	7 1/2	43	1,6	150	5,80

– Standard shipping lengths = 80 pitches = 10 feet = 3,048 metres.



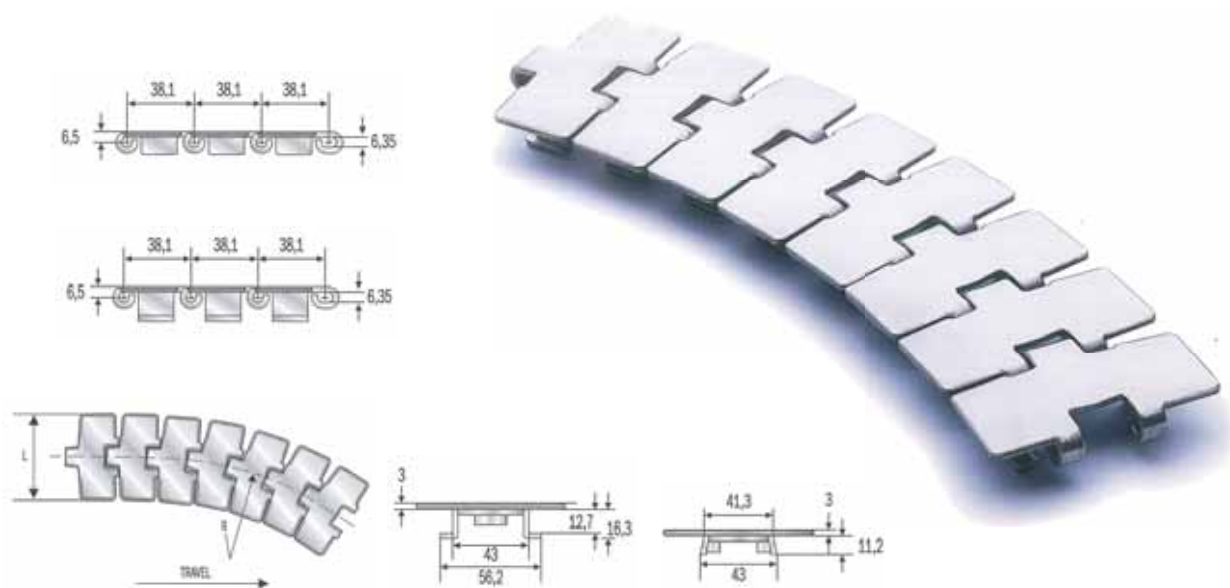

### FLEX RXMC - Inox

- Ferritic, AISI 430 stainless steel slats, work hardened, with shiny surface having low roughness.
- Chrome-nickel, austenitic stainless steel guide shoes (18% Chrome - 8% Nickel), work hardened for high resistance.
- AISI 431 stainless steel pins, magnetic and work hardened for high resistance.

### FLEX RXMS - Hard Inox

- Special, chrome-nickel stainless steel slats, work hardened for high resistance, with shiny surface having a roughness of  $Ra \leq 0.3$  microns.
- Chrome-nickel, austenitic stainless steel guide shoes (18% Chrome - 8% Nickel), work hardened for high resistance.
- AISI 431 stainless steel pins, magnetic and work hardened for high resistance.

Chain Ref.	Model	L=Slat width		R=Minimum sideflexing radius	Weight per metre
		mm.	"	mm.	Kg./m.
SS 881 - K 325	Flex RXMC TAB	82,5	3 1/4	457	3,10

SSH 881 - K 325	Flex RXMC 8	82,5	3 1/4	457	2,90
SSH 881 - K 450	Flex RXMC 8	114,3	4 1/2	500	3,60
SSH 881 - K 750	Flex RXMC 8	190,5	7 1/2	500	5,30
SSH 881 T - K 325	Flex RXMC TAB	82,5	3 1/4	457	3,10
SSH 881 T - K 450	Flex RXMC TAB	114,3	4 1/2	500	3,80
SSH 881 T - K 750	Flex RXMC TAB	190,5	7 1/2	500	5,50

– Standard shipping lengths = 80 pitches = 10 feet = 3,048 metres.

### FLEX RXM - Inox 18/8

- Chrome-nickel austenitic AISI 304 stainless steel slats (18% Chrome - 8% Nickel), work hardened for high resistance - shiny with a roughness of  $Ra \leq 0.5$  microns.
- Chrome-nickel, austenitic stainless steel guide shoes (18% Chrome - 8% Nickel), work hardened for high resistance.
- Austenitic stainless steel pins (18% Chrome - 8% Nickel), work hardened for high resistance.

Designation example	
SS	Material
881	Chain type
K 325	Chain Width

881 Series



### FLEX RXM - Inox 316

- Chrome-nickel, austenitic AISI 304 stainless steel slats (18% Chrome - 8% Nickel), work hardened for high resistance - shiny - with a roughness of  $Ra \leq 0.5$  microns.
- Austenitic stainless steel pins (18% Chrome - 8% Nickel), work hardened for high resistance.

### FLEX - RXMA - Carbon Steel

- Heat-treated carbon steel slats, with a surface and core of 43 HRC.
- Case hardened carbon steel pins.

**Designation example**

SSA — Material  
 881 — Chain type  
 K 325 — Chain Width

Chain Ref.	Model	L=Slat width		R=Minimum sideflexing radius	Weight per metre
		mm.	"	HRC	
SSA 881 - K 325	Flex RXM 8	82,5	3 1/4	457	2,90
SSA 881 - K 450	Flex RXM 8	114,3	4 1/2	500	3,60
SSA 881 - K 750	Flex RXM 8	190,5	7 1/2	500	5,30
SSA 881 T - K 325	Flex RXM 8	82,5	3 1/4	457	3,10
SSA 881 T - K 450	Flex RXM 8	114,3	4 1/2	500	3,80
SSA 881 T - K 750	Flex RXM 8	190,5	7 1/2	500	5,50

SSAA 881 T - K 325	Flex RXM 316 TAB	82,5	3 1/4	457	3,10
SSAA 881 T - K 450	Flex RXM 316 TAB	114,3	4 1/2	500	3,80
SSAA 881 T - K 750	Flex RXM 316 TAB	190,5	7 1/2	500	5,50

S 881 - K 325	Flex RXMA 8	82,5	3 1/4	457	2,90
S 881 - K 450	Flex RXMA 8	114,3	4 1/2	500	3,60
S 881 - K 750	Flex RXMA 8	190,5	7 1/2	500	5,30
S 881 T - K 250	Flex RXMA TAB	63,5	2 1/2	457	2,65
S 881 T - K 325	Flex RXMA TAB	82,5	3 1/4	457	3,10
S 881 T - K 450	Flex RXMA TAB	114,3	4 1/2	500	3,80
S 881 T - K 750	Flex RXMA TAB	190,5	7 1/2	500	5,50

Sideflexing hinged slat chains

– Standard shipping lengths = 80 pitches = 10 feet = 3,048 metres.



8811 Series

**Designation example**

SSH — Material  
 8811 — Chain type  
 K 325 — Chain Width

### FLEX RXM - Inox 18/8

- Chrome-nickel austenitic AISI 304 stainless steel slats (18% Chrome - 8% Nickel), work hardened for high resistance - shiny with a roughness of  $Ra \leq 0.5$  microns.
- Chrome-nickel, austenitic stainless steel guide shoes (18% Chrome - 8% Nickel), work hardened for high resistance.
- Austenitic stainless steel pins (18% Chrome - 8% Nickel), work hardened for high resistance.

### FLEX FMD - Hard Inox

- Special, new stainless steel, chrome-nickel (W.1.4589) slats, work hardened for high resistance, with low surface roughness,  $Ra \leq 0.3$  microns.
- Chrome-nickel, austenitic stainless steel guide shoes (18% Chrome - 8% Nickel), work hardened for high resistance.
- Special martensitic stainless steel pins, magnetic and heat treated for high resistance.

### FLEX FMD - Inox 18/8

- Chrome-nickel austenitic AISI 304 stainless steel slats (18% Chrome - 8% Nickel), work hardened for high resistance - shiny with a roughness of  $Ra \leq 0.5$  microns.
- Chrome-nickel, austenitic stainless steel guide shoes (18% Chrome - 8% Nickel), work hardened for high resistance.
- Austenitic stainless steel pins (18% Chrome - 8% Nickel), work hardened for high resistance.

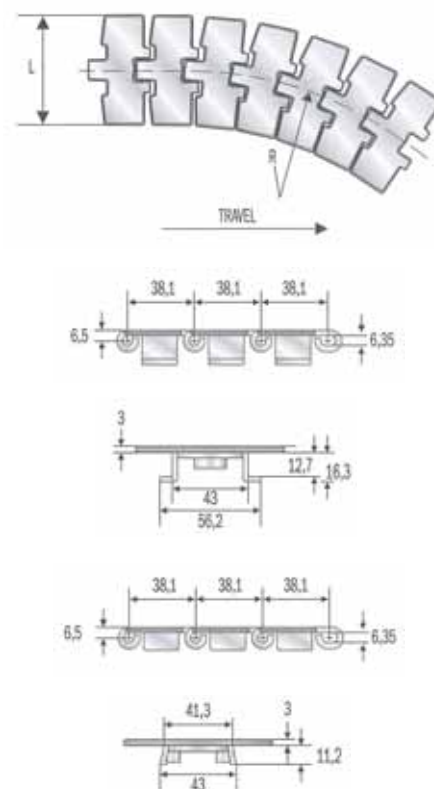

Chain Ref.	Model	L=Slat width		R=Minimum sideflexing radius	Weight per metre
		mm.	"		
SSH 8811 - K 325	Flex FMS 8	82,5	3 1/4	500	2,90
SSH 8811 - K 350	Flex FMS 8	88,9	3 1/2	500	3,10
SSH 8811 T - K 325	Flex FMS TAB	82,5	3 1/4	500	3,10
SSH 8811 T - K 350	Flex FMS TAB	88,9	3 1/2	500	3,30

SSX 8811 - K 325	Flex FMD TAB	82,5	3 1/4	500	3,10
------------------	--------------	------	-------	-----	------

SSA 8811 - K 325	Flex FM 8	82,5	3 1/4	500	2,90
SSA 8811 - K 350	Flex FM 8	88,9	3 1/2	500	3,10
SSA 8811 T - K 325	Flex FM TAB	82,5	3 1/4	500	3,10
SSA 8811 T - K 350	Flex FM TAB	88,9	3 1/2	500	3,30

– Standard shipping lengths = 80 pitches = 10 feet = 3,048 metres.

**881 Radius Series**



**FLEX FMS2 R=200 mm. - Hard Inox**

- Chrome-nickel austenitic AISI 304 stainless steel slats (18% Chrome - 8% Nickel), work hardened for high resistance - shiny with a roughness of  $Ra \leq 0.5$  microns.
- Chrome-nickel, austenitic stainless steel guide shoes (18% Chrome - 8% Nickel), work hardened for high resistance.
- Austenitic stainless steel pins (18% Chrome - 8% Nickel), work hardened for high resistance.

**Designation example**

SSH — Material  
 881 R — Chain type  
 TK 325 — Chain Width

**FLEX FM2 R=200 mm. - Inox 18/8**

- Chrome-nickel austenitic AISI 304 stainless steel slats (18% Chrome - 8% Nickel), work hardened for high resistance - shiny with a roughness of  $Ra \leq 0.5$  microns.
- Chrome-nickel, austenitic stainless steel guide shoes (18% Chrome - 8% Nickel), work hardened for high resistance.
- Austenitic stainless steel pins (18% Chrome - 8% Nickel), work hardened for high resistance.

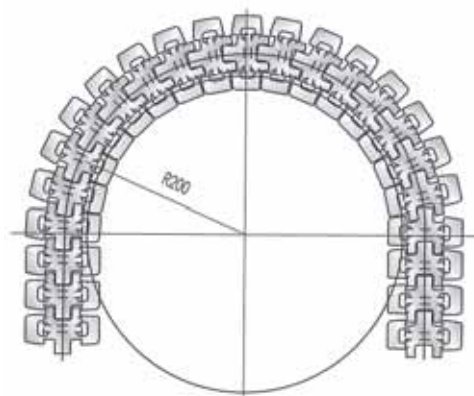
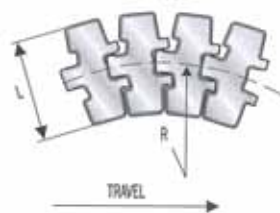
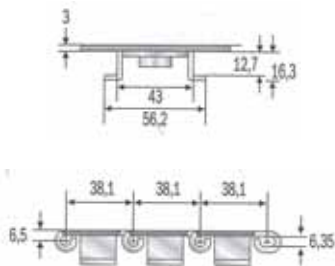

Sideflexing hinged slat chains for magnetic systems

Chain Ref.	Model	L=Slat width		R=Minimum sideflexing radius	Weight per metre
		mm.	"	mm.	Kg./m.
SSH 881 R T - K 325	Flex FMS2 TAB	82,5	3 1/4	200	3,00
SSA 881 R T - K 325	Flex FM2 TAB	82,5	3 1/4	200	3,00

– Standard shipping lengths = 80 pitches = 10 feet = 3,048 metres.  
 Not to be used with lateral curving discs.



881 Magnet Series

### NEW FLEX MAG - Hard Inox

- Special, chrome-nickel, stainless steel slats, work hardened for high resistance - with shiny surface having a roughness of  $Ra \leq 0.3$  microns.
- Special, stainless steel pins, 400 series - magnetic - work hardened for high resistance.

### NEW FLEX MAG D - HQ Inox

- Special, new stainless steel, chrome-nickel (W.1.4589) slats, work hardened for high resistance with very little roughness of  $Ra \leq 0.2$  microns.
- Special martensitic stainless steel pins, magnetic and heat treated for high resistance.

#### Designation example

SSH — Material  
 881 M — Chain type  
 K 325 — Chain Width

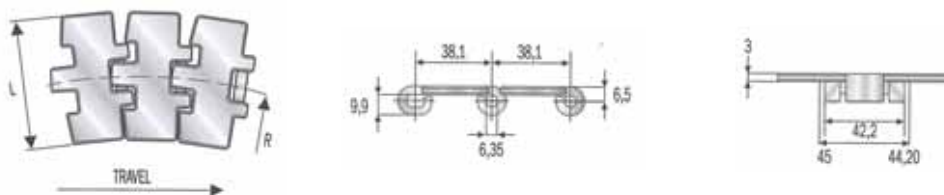

Chain Ref.	Model	L=Slat width		R=Minimum sideflexing radius	Weight per metre
		mm.	"		
SSH 881 M - K 325	New Flex Mag	82,5	3 1/4	500	2,50
SSH 881 M - K 450	New Flex Mag	114,3	4 1/2	500	3,20
SSH 881 M - K 750	New Flex Mag	190,5	7 1/2	500	4,90
SSX 881 M - K 325	New Flex Mag-D	82,5	3 1/4	500	2,50

\* Size produced only upon request.  
 – Standard shipping lengths = 80 pitches = 10 feet = 3,048 metres.

# Straight running chains with rubber inserts for inclined conveyors - Single hinge



**812 Friction Series**

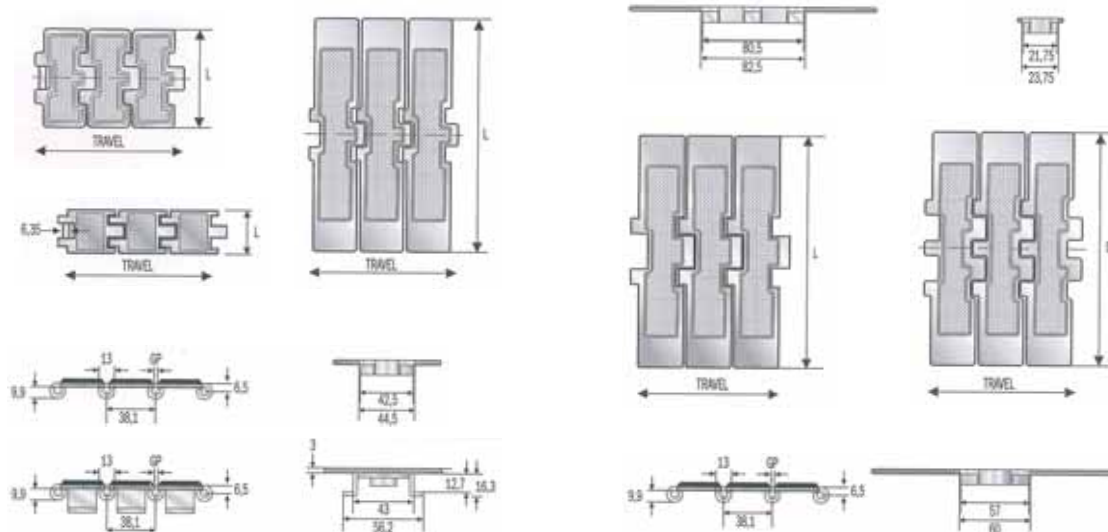

### SUPER-G/DHG - Hard Inox

- Special, chrome-nickel, stainless steel slats, work hardened for high resistance, with rubber insert.
- Chrome-nickel, austenitic stainless steel guide shoes (18% Chrome - 8% Nickel), (Super-G TAB).
- AISI 431 stainless steel pins, magnetic and work hardened for high resistance.

### Designation example

- SSHR — Material
- 812 G — Chain type
- K 125 — Chain Width

Chain Ref.	Model	L=Slat width		Hardness HRC	GP mm.	RCC mm.	Weight per metre Kg./m.
		mm.	"				
SSHR 812 G - K 125	Super-G	31,8	1 1/4	30	2,8	75	1,20
SSHR 812 G - K 325	Super-G	82,5	3 1/4	30	2,8	75	2,80
SSHR 812 T G - K 325	Super-G	82,5	3 1/4	30	2,8	75	3,40
SSH 812 G - K 450	Super-G	114,3	4 1/2	30	1,6	150	3,50
SSH 812 G - K 600	Super-G	152,4	6	30	1,6	150	4,40
SSH 812 G - K 750	Super-G	190,5	7 1/2	30	1,6	150	5,30
SSH 8127 G - K 750	Super-G	190,5	7 1/2	30	1,6	150	5,35
SSH 802 G - K 750	Super-DHG	190,5	7 1/2	30	1,6	150	6,20

– Standard shipping lengths = 80 pitches = 10 feet = 3,048 metres.

Sidexifexing hinged stat chains with rubber inserts for inclined conveyors

# Sideflexing hinged slat chains with rubber inserts for inclined conveyors



881 Friction Series

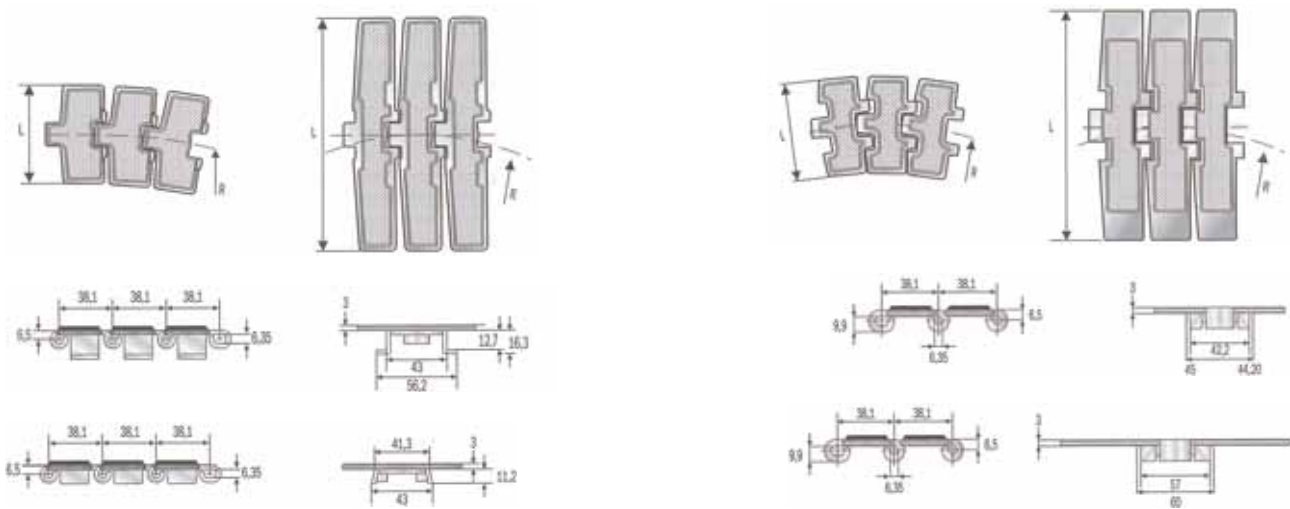

## FLEX RXMS-G NEW FLEX-G MAG - Hard Inox

- Special, chrome-nickel, stainless steel slats, work hardened for high resistance, with a rubber insert.
- Chrome-nickel, austenitic stainless steel guide shoes (18% Chrome - 8% Nickel), (Flex RXMS-G).
- Special, stainless steel pins, 400 series - magnetic - work hardened for high resistance.

### Designation example

- SSH — Material
- 881 G — Chain type
- K 325 — Chain Width

Chain Ref.	Model	L=Slat width		R=Minimum sideflexing radius	Weight per metre
		mm.	"		
SSH 881 G - K 325	Flex RXMS-G 8	82,5	3 1/4	457	3,10
SSH 881 G - K 450	Flex RXMS-G 8	114,3	4 1/2	500	3,80
SSH 881 G - K 750	Flex RXMS-G 8	190,5	7 1/2	500	5,50
SSH 881 T G - K 325	Flex RXMS-G TAB	82,5	3 1/4	457	3,30
SSH 881 T G - K 450	Flex RXMS-G TAB	114,3	4 1/2	500	4,00
SSH 881 T G - K 750	Flex RXMS-G TAB	190,5	7 1/2	500	5,70
SSH 881 M G - K 325	New Flex-G Mag	82,5	3 1/4	500	2,70
SSH 881 M G - K 750	New Flex-G Mag	190,5	7 1/2	500	5,10
SSH 8817 M G - K 750	New Flex-G Mag	190,5	7 1/2	860	5,14

– Standard shipping lengths = 80 pitches = 10 feet = 3,048 metres.

Straight running chains with rubber inserts for inclines conveyors

# "1864" Straight running Plate Top chains

1864 Series

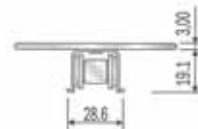
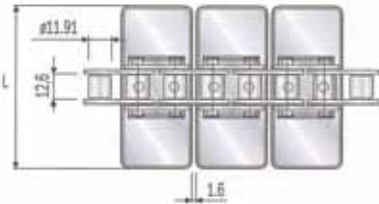

## 1864 SERIES

This high speed, high capacity series offers better efficiency and reliability in applications where high temperatures or abrasive materials are involved.

- Steel and stainless steel top plates.
- Base roller chain, 19,05 mm - 3/4" pitch.

**Designation example**

1864 SS — Chain type  
K 325 — Chain Width

Chain Ref.	Ultimate strength	Base chain material	Top plate material	L=Slat width	Weight per metre
	N			mm.	Kg./m.
1864 - K 325	37000	Carbon	Carbon	82,5	3,33
1864 - K 450			Steel	114,3	4,00
1864 - K 600		Steel	152,4	5,33	
1864 - K 750		Steel	190,5	5,68	

1864 A - K 325	37000	Carbon	Stainless	82,5	3,33
1864 A - K 450			Steel	114,3	4,00
1864 A - K 600		Steel	152,4	5,33	
1864 A - K 750		Steel	190,5	5,68	

1864 SS - K 325	26000	Stainless	Stainless	82,5	3,33
1864 SS - K 450			Steel	114,3	4,00
1864 SS - K 600		Steel	152,4	5,33	
1864 SS - K 750		Steel	190,5	5,68	

– Standard shipping lengths = 80 pitches = 10 feet = 3,048 metres.

"1874" Sideflexing Plate Top chains



# "1874" Sideflexing Plate Top chains

1874 Series

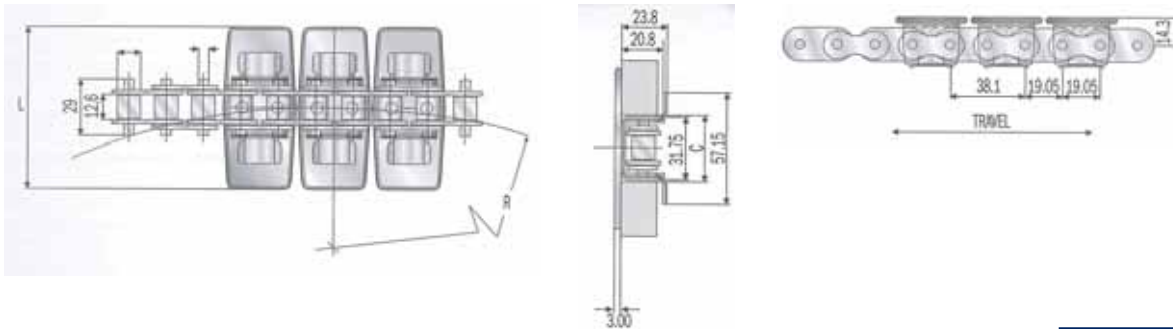

## 1874 SERIES

This high speed, high capacity series offers better efficiency and reliability in applications where high temperatures or abrasive materials are involved.

- Steel and stainless steel top plates.
- Base roller chain, 19,05 mm - 3/4" pitch.

### Designation example

1874 A — Chain type  
K 325 — Chain Width

Chain Ref.	Ultimate strength	Base chain material	Top plate material	L=Slat width	Straight C	Curve C	R=Minimum sideflexing radius	Weight per metre
	N			mm.	mm.	mm.	mm.	Kg./m.
1874 - K 325	27000	Steel	Steel	82,5	34,1	34,6	356	4,20
1874 - K 450				114,3				4,80
1874 - K 600				152,4				5,70
1874 - K 750				190,5				6,40

1874 A - K 325	27000	Steel	Stainless	82,5	34,1	34,6	356	4,20
1874 A - K 450				114,3				4,80
1874 A - K 600				152,4				5,70
1874 A - K 750				190,5				6,40

1874 SS - K 325	21000	Stainless	Stainless	82,5	34,1	34,6	356	4,20
1874 SS - K 450				114,3				4,80
1874 SS - K 600				152,4				5,70
1874 SS - K 750				190,5				6,40

– Standard shipping lengths = 80 pitches = 10 feet = 3,048 metres.

# Sprockets

Reinforced polyamide + screws in stainless steel.

**SPROCKETS**  
815  
812

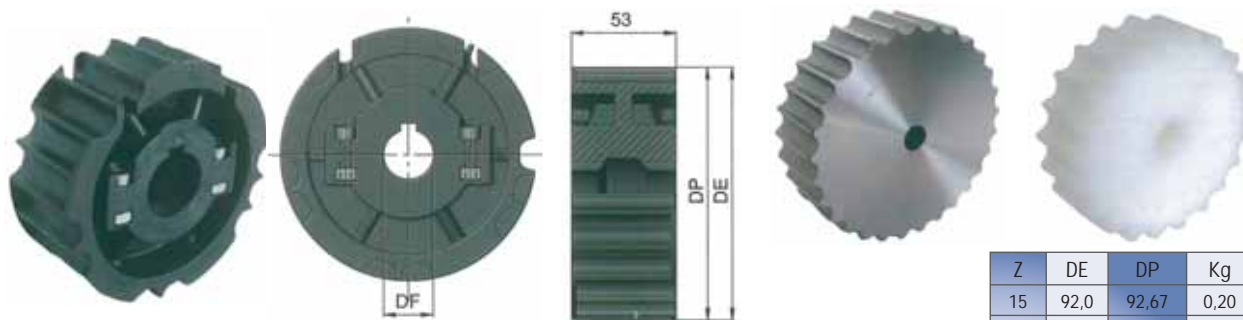

Z	DE	DP	Kg
15	92,0	92,67	0,20
17	104,0	105,47	0,20
19	117,0	117,34	0,30
21	129,0	129,26	0,40
23	141,0	141,22	0,50
25	153,0	153,20	0,60
27	165,0	165,21	0,80
29	177,0	177,23	1,00

Available in moulded and machined execution as split and non-split. Bores with and without keyway.

Reinforced polyamide + screws in stainless steel.

**SPROCKETS**  
820  
831



Z	DE	DP	Kg
15	92,0	92,67	0,18
17	104,0	105,47	0,18
19	117,0	117,34	0,28
21	129,0	129,26	0,38
23	141,0	141,22	0,48
25	153,0	153,20	0,58
27	165,0	165,21	0,78
29	177,0	177,23	0,98



Reinforced polyamide + screws in stainless steel.

Z	DE	DP	DF	Kg
15	93,0	93,67	20	3,5
17	104,0	105,47	20	4,6
19	117,0	117,34	20	5,8
21	129,0	129,26	20	7,2
23	141,0	141,22	20	8,6
25	153,0	153,20	20	10,2

**SPROCKETS**  
805  
821

Reinforced polyamide + screws in stainless steel.

Z	DE	DP	DF	Kg
12	147,2	147,21	25	0,39
			30	
			35	
			40	

Z	DE	DP	DF	Kg
12	147,2	147,21	25	0,39
			30	
			35	
			40	

Z	DE	DP	Kg
9	108,50	111,4	0,2
10	120,50	123,29	0,2
11	134,0	135,23	0,3
12	147,2	147,21	0,4

**SPROCKETS**  
880

Reinforced polyamide + screws in stainless steel.

Z	DE	DP	DF	Kg
19	117,0	117,34	25	0,30
			30	
			35	
			40	
21	129,0	129,26	25	0,40
			30	
			35	
			40	
23	141,0	141,22	25	0,50
			30	
			35	
			40	
25	153,0	153,20	25	0,60
			30	
			35	
			40	

**SPROCKETS**  
881

Sprockets

# Sprockets

Reinforced polyamide + screws in stainless steel.

**SPROCKETS 882**

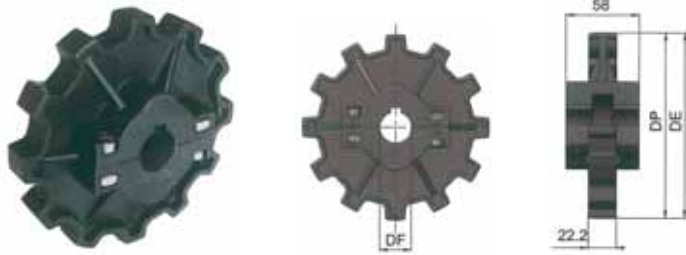

Z	DE	DP	DF	Kg
12	148,5	147,2	25	0,38
			30	
			35	
			40	
45				

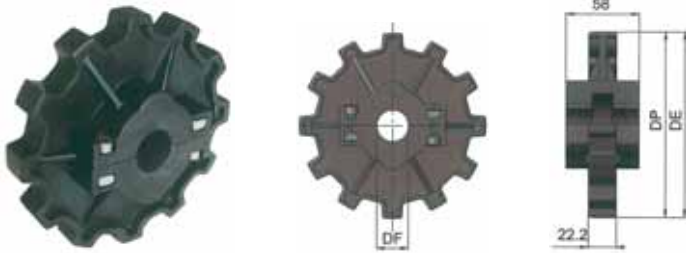

Z	DE	DP	DF	Kg
12	148,5	147,2	25	0,38
			30	
			35	
			40	
45				

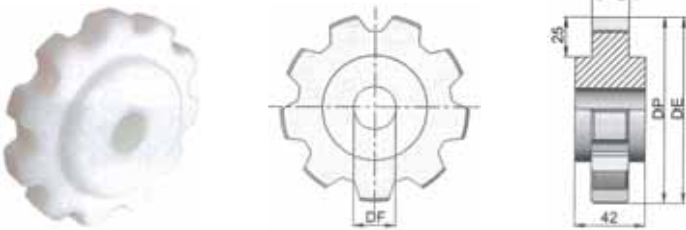

Z	DE	DP	DF	Kg
9	112,5	111,4	25	0,20
			30	
			35	
			40	

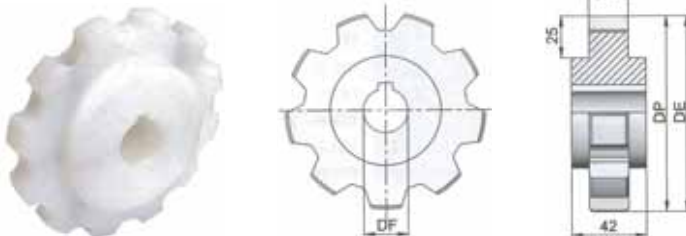

Z	DE	DP	DF	Kg
10	124,9	123,4	25	0,26
			30	
			35	
			40	

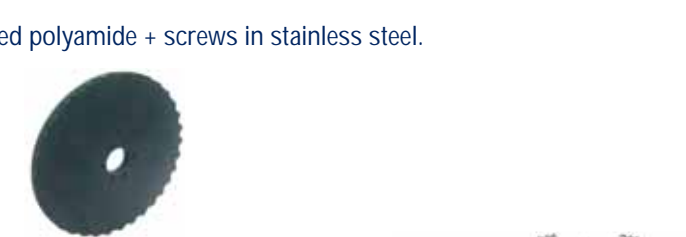

Z	DE	DP	DF	Kg
11	136,4	135,2	25	0,33
			30	
			35	
			40	

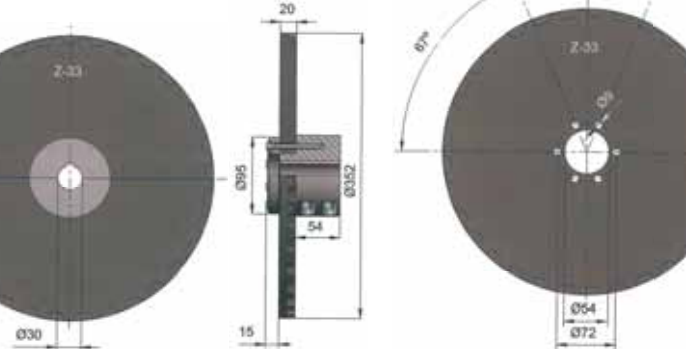

Z	DE	DP	DF	Kg
12	148,5	147,2	25	0,41
			30	
			35	
			40	

Reinforced polyamide + screws in stainless steel.

**SPROCKETS 880 R**

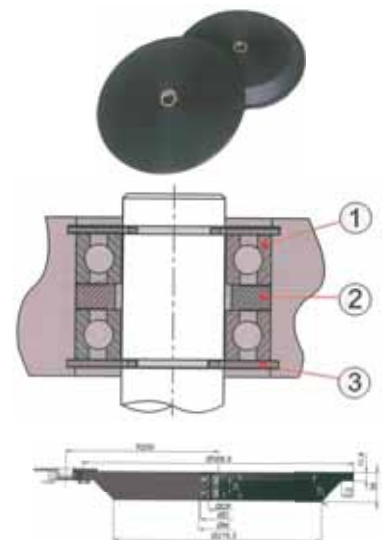

ØDF	ØD	ØM	H	Kg
25	47	51	6	2,20
30	55	60	3	2,20

- 1. DF25/ DF30: Bearing 6005 ZZ, pcs: 2
- 2. DF25: Bearings spacer Ø30 x Ø47 x 6, pcs: 1
- 3. DF25: DIN 472 J47, pcs: 2
- 4. DF25: DIN 472 J55, pcs: 2
- DF30: Bearings spacer Ø35 x Ø55 x 3, pcs: 1

Sprockets

Reinforced polyamide + screws in stainless steel.

**SPROCKETS  
1700**

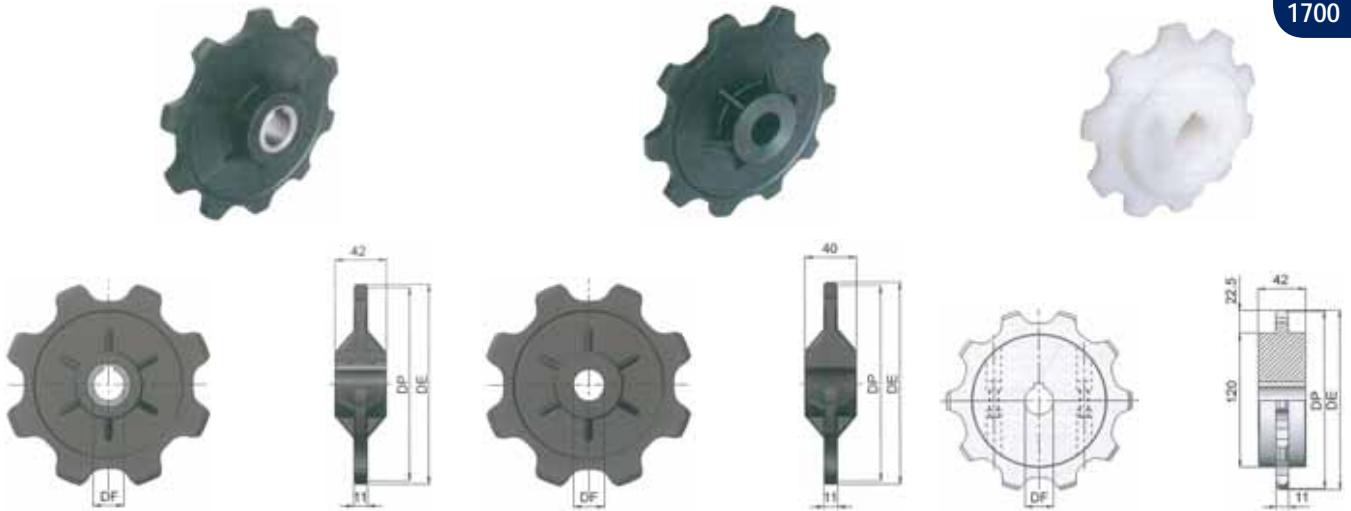

Z	DE	DP	DF	Kg
8	134	130,5	25	0,36
			30	0,40
10	165	161,8	25	0,43
			30	0,47

Z	DE	DP	DF	Kg
8	134	130,5	25	0,18
			30	
10	165	161,8	25	0,28
			30	

Z	DE	DP	DF	Kg
10	165	161,8	25*	0,8
			25	
			30	
			35	
			40	

\* Without key way

Reinforced polyamide + stainless steel.

**SPROCKETS  
CC 600**

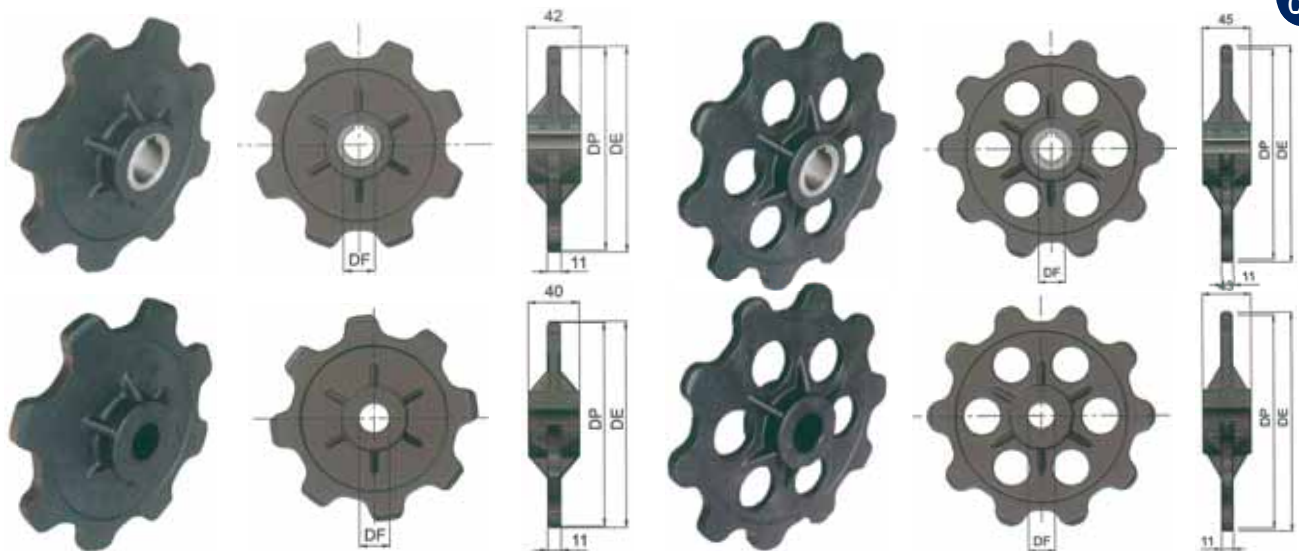

Z	DE	DP	DF	Kg
8	172	166	25	0,51
			30	0,56

Z	DE	DP	DF	Kg
10	215	205,45	25	0,43
			30	0,39

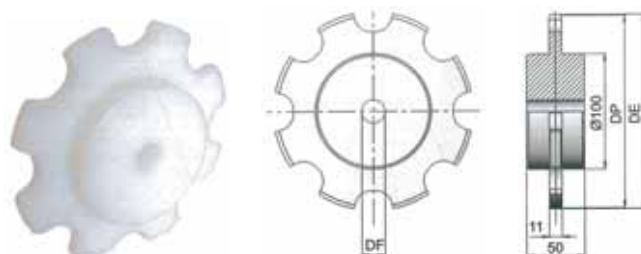

Z	DE	DP	Kg
8	172	165,93	0,600
10	215	205,49	0,800
12	256	245,35	1,100

Low friction/ Acetal.

- Idlers
- 815/820
- 831
- 879
- 880
- 881
- 881 M

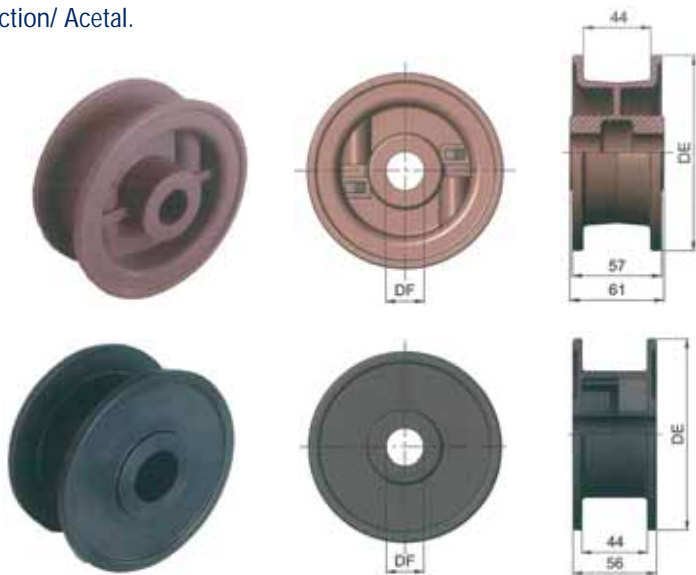

Z	DE	DP	Kg
19	117,0	-	0,2
21	129,0	-	0,2
23	141,0	-	0,3
25	153,0	-	0,3

Acetal.

- Idlers
- 879 TAB
- 880 TAB
- 880 BO
- 881 TAB

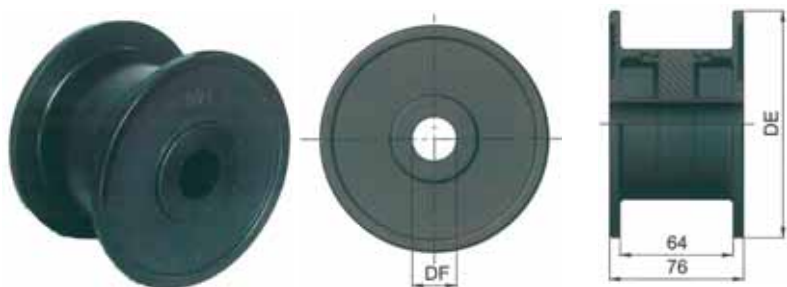

Z	DE	DP	DF	Kg
19	117,0	-	25	0,3
			30	
			35	
			40	
21	129,0	-	25	0,3
			30	
			35	
			40	
23	141,0	-	25	0,3
			30	
			35	
			40	
25	153,0	-	25	0,4
			30	
			35	
			40	

Acetal.

- Idlers
- 805

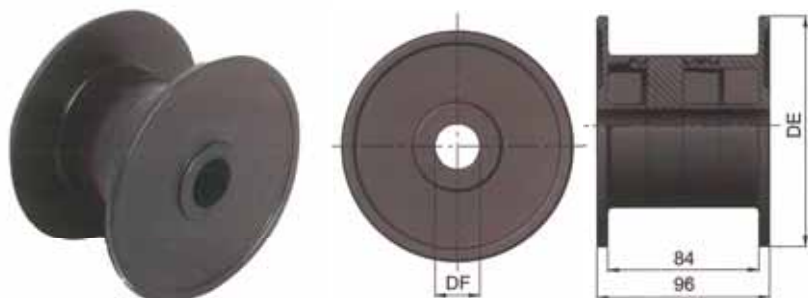

Z	DE	DP	DF	Kg
19	117,0	-	25	0,3
			30	
			35	
			40	
21	129,0	-	25	0,3
			30	
			35	
			40	
23	141,0	-	25	0,3
			30	
			35	
			40	
25	153,0	-	25	0,4
			30	
			35	
			40	

Idlers

## Acetal.

Z	DE	DP	DF	Kg
19	117,0	-	25	0,3
			30	
			35	
			40	
21	129,0	-	25	0,3
			30	
			35	
			40	
23	141,0	-	25	0,3
			30	
			35	
			40	
25	153,0	-	25	0,4
			30	
			35	
			40	



**Idlers  
821**

## Reinforced polyamide.

Z	DE	DP	DF	Kg
17	104	-	20	0,4
			25	
			30	
			35	
			40	
19	117,0	-	20	0,5
			25	
			30	
			35	
			40	
21	129,0	-	20	0,6
			25	
			30	
			35	
			40	
23	141,0	-	20	0,7
			25	
			30	
			35	
			40	
25	153,0	-	20	0,9
			25	
			30	
			35	
			40	

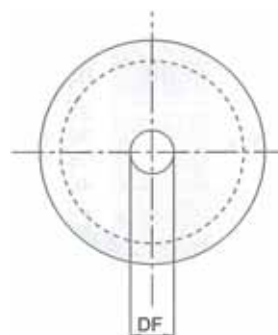

**Idlers  
815  
820  
831  
879  
880  
881  
881 M**

## Reinforced polyamide.

Z	DE	DP	DF	Kg
17	104	-	20	0,6
			25	
			30	
			35	
			40	
19	117,0	-	20	0,8
			25	
			30	
			35	
			40	
21	129,0	-	20	1,0
			25	
			30	
			35	
			40	
23	141,0	-	20	1,2
			25	
			30	
			35	
			40	
25	153,0	-	20	1,4
			25	
			30	
			35	
			40	

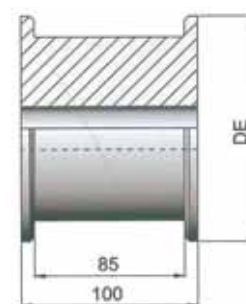
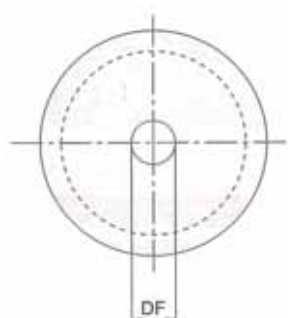

**Idlers  
805**

We are the leading distributor of Thermoplastic bearing units from ANB.

There are many reasons to use ANB housings, such as:

- 100% corrosion resistant PBT reinforced material.
- 100% plain mounting surface to avoid debris getting trapped.
- Stainless steel greasing nipple.
- All seals and caps with stainless springs.
- FDA & FSDA approved.
- 100% smooth surface for minimised bacteria growth.
- Stainless and seamless insert reinforcements in the mounting holes.
- Caps DO NOT FALL OFF.
- 100% interchangeable with cast iron units.
- Temperatures from -35 to 102 degrees C.

**We supply the ANB housings from stock in Green, White and Black colour.**

Units can either be assembled with High-Quality bearings or "Economy" bearings.  
3D drawings available upon request.





You can choose between ANB inserts or "Economy" inserts (SSUC)

### Technical data

- No corrosion
- FDA&FSDA approval
- From 12 to 50 mm.
- Interchangeable with cast iron standarts units
- Maintenance free
- Temperature work from - 35 to 102 degree
- Tensile strength at break (ASTM 0630) is an impressive 17.300 PSI
- Excellent mechanical strengths stiffness and dimension stability
- Stainless Steel greaser and inserts
- Solid base prevents dirt and bacteria
- Reluabe

### Options

- Closed covers
- Open covers (with Stainless Steel spring)
- Back seals
- Plastic seals
- Plastic covers for grease nipple
- Color

### Bearing inserts

- Stainless Steel type MUC
- Stainless Steel type MB
- Steel UC
- Steel B
- Economy stainless steel type SSUC

### Material

- Housing: Exclusive PBT
- Stainless Steel 304 inserts
- Stainless Steel 304 greaser
- Cover: Polypropylene
- Stainless Steel ring

### Designation example

MUC PPL — Type  
206 — Size  
White — Colour

PPL

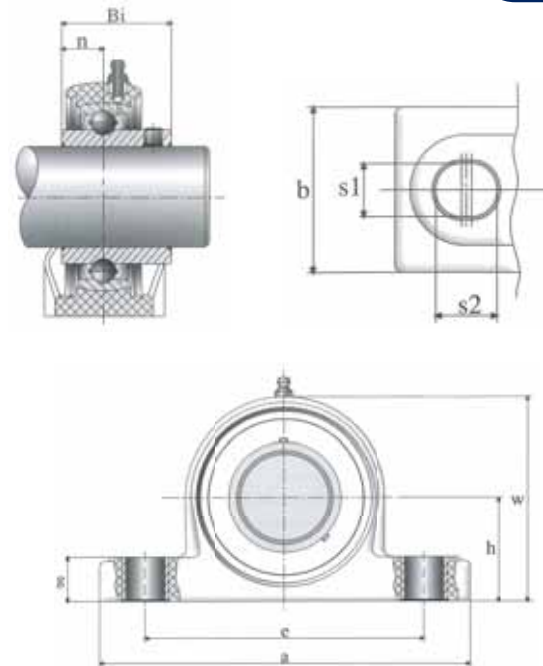

Mode of load	Breaking point test						
	204	205	206	207	208	209	210
	8800	13700	12650	12750	13100	13360	13850
	7700	10000	10600	10800	11100	11400	11750
	5000	8100	5750	7500	8500	8950	9550

Housing number	Shaft diameter		Dimensions (mm)										Weight (Kg.)	max. Torque	
	mm.	inch	h	a	e	b	s1	s2	g	w	Bi	n		bolt d.	Nm
PPL204	12	1/2	33,3	127	95	38	11	14	14,2	65,5	31	12,7	0,32	M10	18
PPL204	15	9/16,5/8	33,3	127	95	38	11	14	14,2	65,5	31	12,7	0,31	M10	18
PPL204	17	11/16	33,3	127	95	38	11	14	14,2	65,5	31	12,7	0,30	M10	18
PPL204	20	3/4	33,3	127	95	38	11	14	14,2	65,5	31	12,7	0,29	M10	18
PPL205	25	13/16,7/8,15/16,1	36,5	140,5	105	38	11	14	14,5	71	34	14,3	0,34	M10	25
PPL206	30	11/16,11/8,13/16,11/14	42,9	163	119	46	14	18	17,8	84	38,1	15,9	0,54	M12	30
PPL207	35	11/4,15/16,13/8,17/16	47,6	168	127	48	14	18	18	94,5	42,9	17,5	0,78	M12	35
PPL208	40	11/12,19/16	49,2	184	137	54	14	18	19,5	99	49,2	19	0,97	M12	45
PPL209	45	15/8,111/16,13/4	54	192	146	54	17	20	23	106	49,2	19	1,09	M16	50
PPL210	50	113/16,17/8,115/16,2	57,2	206	159	60	17	20	23	114	51,6	19	1,20	M16	55

– Thermoplastic housed pillow blocks.

# Thermoplastic bearing units

## NFL



**Designation example**  
MUC NFL — Type  
204 — Size  
White — Colour

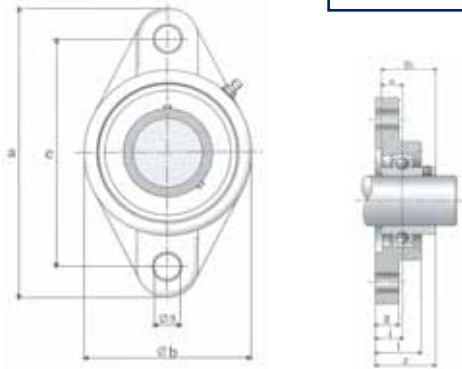

Mode of load	Breaking point test						
	204	205	206	207	208	209	210
	11750	11375	16450	16900	17350	17600	17950
	11000	13850	13350	13950	14050	14300	14550
	8500	11100	14200	14900	14900	15150	15650

Housing number	Shaft diameter		Dimensions (mm)										Weight (Kg.)	max. Torque	
	mm.	inch	a	e	b	g	l	s	z	i	Bi	n		bolt d.	Nm
NFL204	12	1/2	114	90	65	11,4	26,5	11	33,7	15,4	31	12,7	0,27	M10	18
NFL204	15	9/16,5/8	114	90	65	11,4	26,5	11	33,7	15,4	31	12,7	0,26	M10	18
NFL204	17	11/16	114	90	65	11,4	26,5	11	33,7	15,4	31	12,7	0,25	M10	18
NFL204	20	3/4	114	90	65	11,4	26,5	11	33,7	15,4	31	12,7	0,24	M10	18
NFL205	25	13/16,7/8,15/16,1	131	99	69,5	13,5	29,1	11	36,7	17	34	14,3	0,30	M10	25
NFL206	30	11/16,11/8,13/16,11/14	148	117	80	13,3	30,5	11	41,2	19	38,1	15,9	0,45	M10	30
NFL207	35	11/4,15/16,13/8,17/16	164	130	90	16,1	32,8	13	43,4	18	42,9	17,5	0,66	M12	35
NFL208	40	11/12,19/16	176	144	100	20	37,5	14	51,7	21,5	49,2	19	0,87	M12	40
NFL209	45	15/8,111/16,13/4	188,5	148,5	108	21	41	17	54,2	24	49,2	19	1,00	M16	45
NFL210	50	113/16,17/8,115/16,2	197	157	115	21	43	17	57,6	25	51,6	19	1,20	M16	50

– Thermoplastic housed 2-bolt flange.

## FPL



**Designation example**  
MUC FPL — Type  
204 — Size  
White — Colour

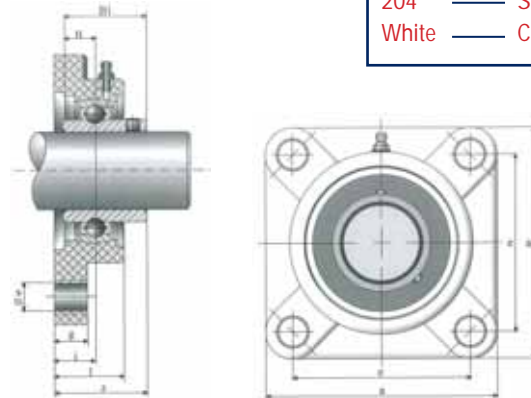

Mode of load	Breaking point test						
	204	205	206	207	208	209	210
	15950	13000	18000	18500	19100	19350	19650
	10250	12150	17700	18500	19250	19350	19620
	3650	3350	3350	3520	3790	3850	3990

Housing number	Shaft diameter		Dimensions (mm)										Weight (Kg.)	max. Torque	
	mm.	inch	a	e	g	l	s	z	i	Bi	n	bolt d.		Nm	
FPL204	12	1/2	87	63,5	13,4	27,8	11	36,3	18	31	12,7	0,32	M10	18	
FPL204	15	9/16,5/8	87	63,5	13,4	27,8	11	36,3	18	31	12,7	0,31	M10	18	
FPL204	17	11/16	87	63,5	13,4	27,8	11	36,3	18	31	12,7	0,30	M10	18	
FPL204	20	3/4	87	63,5	13,4	27,8	11	36,3	18	31	12,7	0,29	M10	18	
FPL205	25	13/16,7/8,15/16,1	95	70	14,3	28	11	36,7	17	34	14,3	0,36	M10	25	
FPL206	30	11/16,11/8,13/16,11/14	107	83	14,3	31,5	11	41,4	19,2	38,1	15,9	0,50	M10	30	
FPL207	35	11/4,15/16,13/8,17/16	118	92	15,5	34,8	13	46,9	21,5	42,9	17,5	0,74	M12	35	
FPL208	40	11/12,19/16	130	102	17	37,5	14	53,2	23	49,2	19	0,97	M12	40	
FPL209	45	15/8,111/16,13/4	137	105	19	41	17	54,2	24	49,2	19	1,10	M16	45	
FPL210	50	113/16,17/8,115/16,2	143	111	21	43	17	57,2	25	51,6	19	1,25	M16	50	



– Thermoplastic housed square flange.

## Designation example

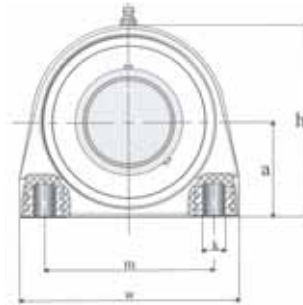
MUC TBL — Type  
204 — Size  
White — Colour



TBL

Mode of load	Breaking point test						
	204	205	206	207	208	209	210
	8210	8540	10370	12150	12230	12900	13850
	6900	7010	6580	8080	9100	10400	11050
	2980	2850	4950	8160	9800	10710	11360

Housing number	Shaft diameter		Dimensions (mm)								Weight (Kg.)	max. Torque	
	mm.	inch	a	b	h	m	w	k	Bi	n		bolt d.	Nm
TBL204	12	1/2	33,3	34,5	66	50,8	72,8	M8	31	12,7	0,38	M8	18
TBL204	15	9/16,5/8	33,3	34,5	66	50,8	72,8	M8	31	12,7	0,37	M8	18
TBL204	17	11/16	33,3	34,5	66	50,8	72,8	M8	31	12,7	0,36	M8	18
TBL204	20	3/4	33,3	34,5	66	50,8	72,8	M8	31	12,7	0,35	M8	18
TBL205	25	13/16,7/8,15/16,1	36,5	39,5	73,5	50,8	76,2	M10	34	14,3	0,40	M10	25
TBL206	30	11/16,11/8,13/16,11/14	42,9	42,5	84	76,2	101	M10	38,1	15,9	0,55	M10	30
TBL207	35	11/4,15/16,13/8,17/16	47,6	47,5	95	82,6	110	M10	42,9	17,5	0,80	M10	35
TBL208	40	11/12,19/16	49,2	48	100,5	88,9	120	M12	49,2	19	0,95	M12	45
TBL209	45	15/8,11/16,13/4	54	50	108,5	95,3	124	M12	49,2	19	1,10	M16	50
TBL210	50	113/16,17/8,115/16,2	57,2	54	115	101,6	135	M16	51,6	19	1,25	M16	55



– Thermoplastic housed tapped base.

## Designation example

MUC FBL — Type  
204 — Size  
White — Colour

FBL



Mode of load	Breaking point test			
	204	205	206	207
	7200	9100	12200	12900
	9200	11100	11800	11900
	2600	2800	2900	3100

Housing number	Shaft diameter		Dimensions (mm)													Weight (Kg.)	max. Torque	
	mm.	inch	a	b	c	d	e	f	g	h	i	j	k	m	n		bolt d.	Nm
FBL204	12	1/2	76,2	62	38,1	42,9	33,7	22,2	11,4	108	63,5	26,5	10,7	18,3	12,7	0,28	M10	18
FBL204	15	9/16,5/8	76,2	62	38,1	42,9	33,7	22,2	11,4	108	63,5	26,5	10,7	18,3	12,7	0,26	M10	18
FBL204	17	11/16	76,2	62	38,1	42,9	33,7	22,2	11,4	108	63,5	26,5	10,7	18,3	12,7	0,25	M10	18
FBL204	20	3/4	76,2	62	38,1	42,9	33,7	22,2	11,4	108	63,5	26,5	10,7	18,3	12,7	0,25	M10	18
FBL205	25	13/16,7/8,15/16,1	85,7	63,5	41,3	46	41,2	28,6	11,4	120,6	70	34	10,7	19,7	14,3	0,30	M10	25
FBL206	30	11/16,11/8,13/16,11/14	96,5	76	47,6	52,4	41,5	31,8	13,3	138,5	83	32	10,7	22,2	15,9	0,46	M10	30
FBL207	35	11/4,15/16,13/8,17/16	109,5	89	50,8	60,3	47,1	31,8	16,1	157	95	36,5	13,1	25,4	17,5	0,66	M12	35

– Thermoplastic housed 3-bolt flange.

# Thermoplastic bearing units

## TPL

### Designation example

MUC TPL — Type  
 204 — Size  
 White — Colour

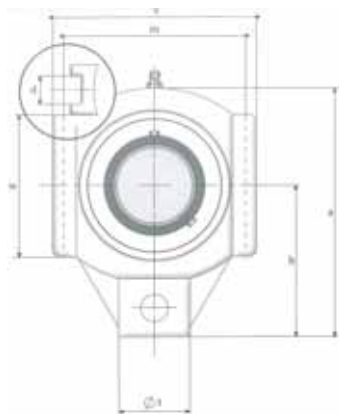

Mode of load	Breaking point test						
	204	205	206	207	208	209	210
	14800	15500	15800	16500	17300	18210	18860
	3930	4530	5100	6500	7800	8710	9750
	8500	10350	10900	11300	12150	12900	13550
	40770	45300	46100	44100	42800	44230	44880



Housing number	Shaft diameter		Dimensions (mm)											Weight (Kg.)
	mm.	inch	a	c	d	h	m	s	t	v	w	Bi	n	
TPL204	12	1/2	99	27,5	12	64	76	M16	36	89	47	31	12,7	0,38
TPL204	15	9/16,5/8	99	27,5	12	64	76	M16	36	89	47	31	12,7	0,37
TPL204	17	11/16	99	27,5	12	64	76	M16	36	89	47	31	12,7	0,36
TPL204	20	3/4	99	27,5	12	64	76	M16	36	89	47	31	12,7	0,35
TPL205	25	13/16,7/8,15/16,1	99	27,5	12	64	76	M16	36	89	47	34	14,3	0,40
TPL206	30	11/16,11/8,13/16,11/4	125	34,5	12	76	89	M16	40	102,5	63	38,1	15,9	0,55
TPL207	35	11/4,15/16,13/8,17/16	125	34,5	12	76	89	M16	40	102,5	63	42,9	17,5	0,80
TPL208	40	11/2,19/16	140	34,5	16	85	102	M16	40	113	80	49,2	19	0,95
TPL209	45	15/8,11/16,13/4	149	40	16	90	102	M20	50	117	85	49,2	19	1,10
TPL210	50	113/16,17/8,115/16,2	149	40	16	90	102	M20	50	117	85	51,6	19	1,25

– Thermoplastic housed take-up unit.

## HPL

### Designation example

MUC HPL — Type  
 204 — Size  
 White — Colour

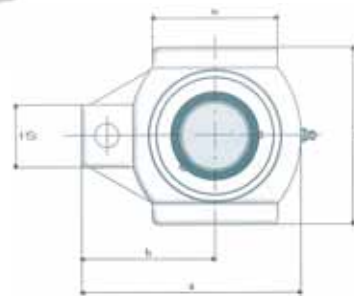

Mode of load	Breaking point test						
	204	205	206	207	208	209	210
	14800	15500	15800	16500	17300	18210	18860
	3930	4530	5100	6500	7800	8710	9750
	8500	10350	10900	11300	12150	12900	13550
	40770	45300	46100	44100	42800	44230	44880

Housing number	Shaft diameter		Dimensions (mm)										Weight (Kg.)
	mm.	inch	a	c	h	m	s	t	w	Bi	n		
HPL204	12	1/2	99	27,5	63,5	65	M16	36	47	31	12,7	0,38	
HPL204	15	9/16,5/8	99	27,5	63,5	65	M16	36	47	31	12,7	0,37	
HPL204	17	11/16	99	27,5	63,5	65	M16	36	47	31	12,7	0,36	
HPL204	20	3/4	99	27,5	63,5	65	M16	36	47	31	12,7	0,35	
HPL205	25	13/16,7/8,15/16,1	99	27,5	63,5	74	M16	36	47	34	14,3	0,40	
HPL206	30	11/16,11/8,13/16,11/4	125	34,5	76	90	M16	40	63	38,1	15,9	0,55	
HPL207	35	11/4,15/16,13/8,17/16	125	34,5	76	90	M16	40	63	42,9	17,5	0,80	
HPL208	40	11/2,19/16	140	34,5	85	100	M16	40	80	49,2	19	0,90	
HPL209	45	15/8,11/16,13/4	149	40	90	110	M20	50	85	49,2	19	1,10	
HPL210	50	113/16,17/8,115/16,2	149	40	90	110	M20	50	85	51,6	19	1,20	



– Thermoplastic housed hanger unit.

**Designation example**  
 MUC CTL — Type  
 204 — Size  
 White — Colour

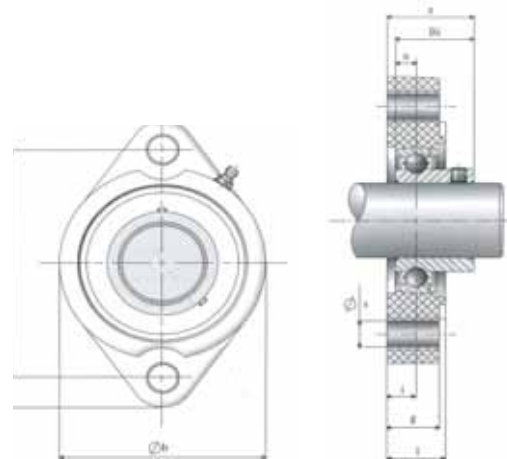

**CTL**

Mode of load	Breaking point test				
	204	205	206	207	208
	9900	10100	14000	14300	14700
	9300	11700	11300	11800	11900
	7200	9400	12000	12600	12800

Housing number	Shaft diameter		Dimensions (mm)										Weight (Kg.)	max. Torque	
	mm.	inch	a	e	b	g	l	s	z	Bi	n	i		bolt d.	Nm
CTL204	20	1/2	90,5	71,4	66,5	18,4	20	9	27	24,7	7	9,5	0,17	M8	15
CTL205	25	13/16,7/8,15/16,1	97	76,2	71	18,4	21,2	9	29,5	27	7,5	10,0	0,22	M8	15
CTL206	30	11/16,11/8,13/16,11/14	112,5	90,5	84	20,5	23,3	11	33,5	30,3	8	11,5	0,34	M10	20
CTL207	35	11/4,15/16,13/8,17/16	126	100	94	22,5	25,3	11	36,5	32,9	8,5	12,5	0,49	M10	25
CTL208	40	11/2,19/16	150	119	100	24	26,8	14	39,5	35,5	9	13,5	0,62	M12	30

– Thermoplastic housed 2 bolt range.

**Designation example**  
 MUC LPPL– Type  
 203 — Size  
 White — Colour

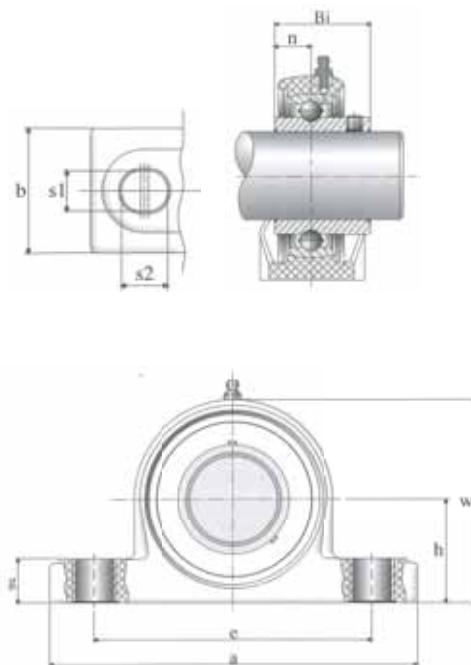

**L-PPL**

Mode of load	Breaking point test
	201-203
	8100
	7200
	4800

Housing number	Shaft diameter		Dimensions (mm)										Weight (Kg.)	max. Torque	
	mm.	inch	h	a	e	b	S1	S2	g	w	Bi	n		bolt d.	Nm
L-PPL203	12	1/2	30,2	114	87	25	11	14	14,2	57	26	10	0,24	M10	16
L-PPL203	15	9/16,5/8	30,2	114	87	25	11	14	14,2	57	26	10	0,23	M10	16
L-PPL203	17	11/16	30,2	114	87	25	11	14	14,2	57	26	10	0,22	M10	16

– Thermoplastic housed light pillow blocks.

# Thermoplastic bearing units

## L-FPL

Mode of load	Breaking point test	
	201-203	
	14500	
	9250	
	3550	

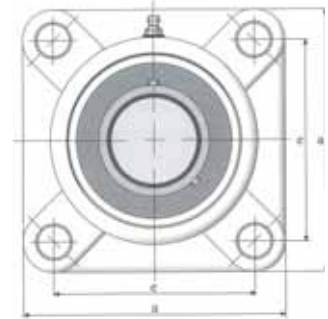
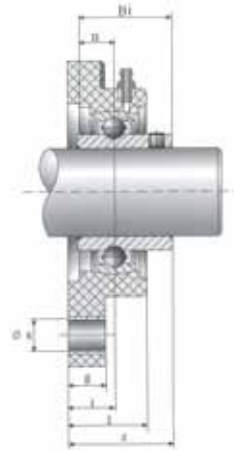

### Designation example

MUC FPL — Type  
 203 — Size  
 White — Colour

Housing number	Shaft diameter		Dimensions (mm)									Weight (Kg.)	max. Torque	
	mm.	inch	a	e	g	l	s	z	i	Bi	n		bolt d.	Nm
L-FPL203	12	1/2	77	54	13,3	28	10,7	33	17	26	10	0,24	M10	16
L-FPL203	15	9/16,5/8	77	54	13,3	28	10,7	33	17	26	10	0,23	M10	16
L-FPL203	17	11/16	77	54	13,3	28	10,7	33	17	26	10	0,22	M10	16
L-FPL203	20	3/4	77	54	13,3	28	10,7	34,7	17	24,7	7	0,24	M10	16

– Thermoplastic housed light 4-hole flange.

## LXL

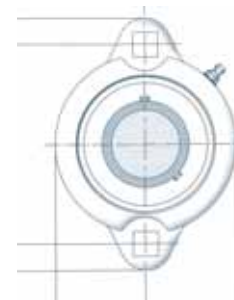
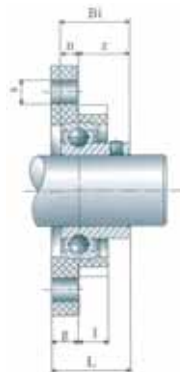

### Designation example

MBLXL — Type  
 203 — Size  
 White — Colour

Mode of load	Breaking point test				
	203	204	205	206	207
	8000	8400	8800	11500	11800
	7800	8500	9200	10900	11600
	5200	6300	8600	10300	10500

Housing number	Shaft diameter	Dimensions (mm)										bolt size	Weight
	mm.	a	c	h	m	s	t	w	Bi	L	n	(mm)	(Kg.)
MBLXL203	12	81	64	10	8	7	56	16	22	28,6	6	M6	0,26
MBLXL203	15	81	64	10	8	7	56	16	22	28,6	6	M6	0,26
MBLXL203	17	81	64	10	8	7	56	16	22	28,6	6	M6	0,24
MBLXL204	20	90	71	11	9	9	63	17,5	24,7	31	7	M8	0,28
MBLXL205	25	95	76	11	10	9	69	19,5	27	31	7,5	M8	0,36
MBLXL206	30	113	90	12	11	11,5	79	22,5	30,3	35,7	8	M10	0,56
MBLXL207	35	122	100	13	11	11,5	89	24,5	32,9	38,9	8,5	M10	0,79



– Thermoplastic housed 2-hole flange.

## Designation example

MBLFL — Type  
 203 — Size  
 White — Colour



LFL

Mode of load	Breaking point test				
	203	204	205	206	207
	8000	8400	8800	11500	11800
	7800	8500	9200	10900	11600
	5200	6300	8600	10300	10500

Housing number	Shaft diameter mm.	Dimensions (mm)										bolt size (mm)	Weight (Kg.)
		a	e	g	l	s	b	z	Bi	L	n		
MBLFL203	12	81	64	10	8	7	56	16	22	28,6	6	M6	0,26
MBLFL203	15	81	64	10	8	7	56	16	22	28,6	6	M6	0,25
MBLFL203	17	81	64	10	8	7	56	16	22	28,6	6	M6	0,24
MBLFL204	20	90	71	11	9	10	63	17,5	24,7	31	7	M8	0,28
MBLFL205	25	95	76	11	10	10	69	19,5	27	31	7,5	M8	0,36
MBLFL206	30	113	90	12	11	11,5	79	22,5	30,3	35,7	8	M10	0,56
MBLFL207	35	122	100	13	11	11,5	89	24,5	32,9	38,9	8,5	M10	0,79

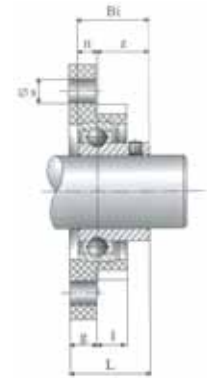

– Thermoplastic housed 2-hole flange.

## Covers - Thermoplastic units



# Covers - Dimensions / Material

Dimensions /Material

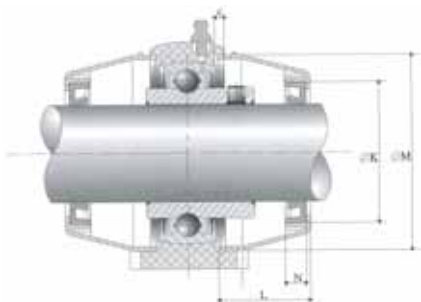
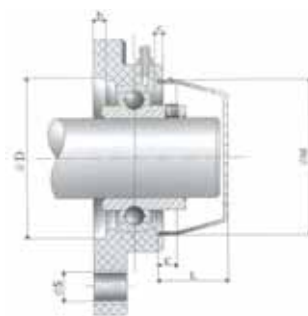
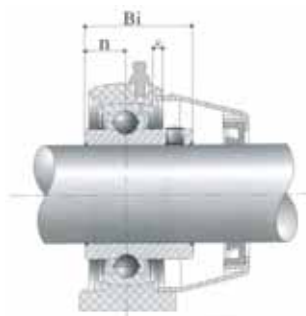
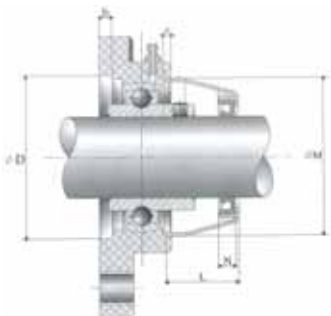

Shaft diameter		Dimensions (mm)						
mm.	inch	K	N	L	M	D	b	c
12	1/2	28	7	22	45	46	6	2,5
15	9/16,5/8	28	7	22	45	46	6	2,5
17	11/16	28	7	22	45	46	6	2,5
20	3/4	32	7	23	50	52	6	3
25	13/16,7/8,15/16,1	37	7	25	55	62	6	4
30	11/16,11/8,13/16,11/4	42	7	30	64	72	6	4
35	11/4,115/16,13/8,17/16	47	7	32	74,5	82	6	4,5
40	11/2,19/16	52	7	37	84	88	6	3,5
45	15/8,111/16,13/4	57	7	41	89	93	6	4,5
50	113/16,17/8,115/16,2	62	7	47	94	98	6	5

### Physical properties

Properties	Unit	Test method	Value
Density	G/cm <sup>3</sup>	DIN 53479	1,53
Water absorption (23 <sup>o</sup> )	%	DIN 53495	0,5
Mould Shrinkage	%	-	0,4
Moisture absorption (23 <sup>o</sup> )	%	DIN 53714	0,2

### Mechanical properties

Properties	Unit	Test method	Value
Tensile yield strength	MPa	ASTM-D638	12
Elongation at break	%	ASTM-D638	1125
Flexural strength	MPa	ASTM-D790	29
Notched izod impact	J/m	ASTM-D256	12

### Thermal properties

Properties	Unit	Test method	Value
HDT at load 1,8 Mpa	°C	DIN 53461	210
HDT at load 0,45 MPa	°C	DIN 53461	220
Melting point	°C	-	225
UL Flammability (thickness)	°C	UL 94	HB
Max. Temp in glow wire test	°C	IEC 695/2/1	
2 mm. thickness			750
4 mm. thickness			960

### Electrical properties

Properties	Unit	Test method	Value
Dielectric constant at 1 MHz	-	IEC 250	3,8
Dielectric	Kv/mm.	VDE 0303/2	34
Volume resistivity	Ohm x cm.	VDE 0303/2	>10 <sup>15</sup>
Surface resistivity	ohm	VDE 0303/2	>10 <sup>15</sup>



**Back Seals**



**Back Seals**

Back seal eliminates the down-time associated with particles that invade bearing components and ultimately cause failure.

Back Seal eliminates the down-time associated with peeling, chipping and flaking of the housing.

They can be used with B steel insert or Special MB Stainless Steel inserts.

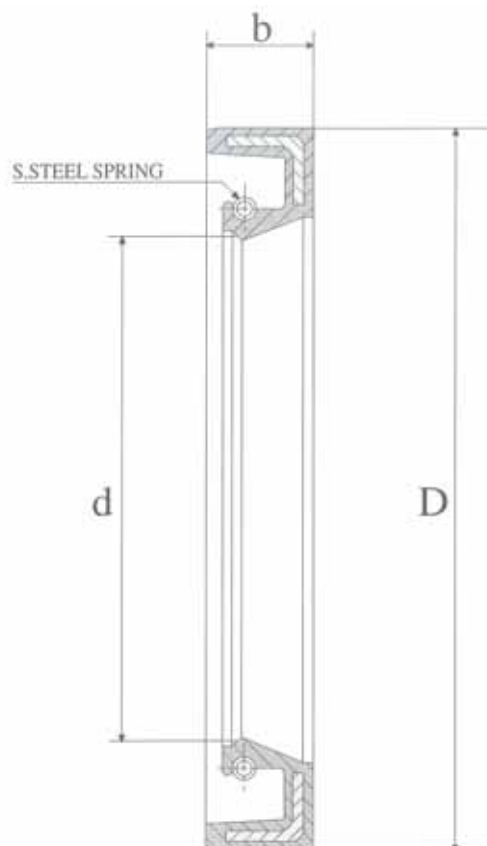

Size	Dimensions (mm)		
	d	b	D
201	12	6	46
202	15	6	46
203	17	6	46
204	20	6	52
205	25	6	62
206	30	6	72
207	35	6	82
208	40	6	88
209	45	6	93
210	50	6	98

- Back Seals.

### Technical data

Our 100% Stainless Steel units are manufactured from a select grade of Stainless Steel which has been carefully chosen to give you what you have asked for: optimal corrosion resistance. Bearing life is excellent because it is not limited to the life of the coating and/or nickel plating.

### Operating temperatures range

-20~+120c.

Scratches and marks have absolutely no effect on the bearings ability to resist rust and corrosion.

Excellent for use in food processing, beverage and other high-corrosive applications, these bearings are 100% stainless throughout: housing, balls, inner and outer races, cages, slingers and set screws.

Material	Unit MUC200
Ring and Balls	SUS440C
Slinger and Retainer	SUS304
Seal	Nitril rubber (NBR)
Set screw	SUS304
Housing	SCS13

Tolerance for SS bearing inner rings								
Nominal Bore DIA (mm.)		Bore diameter				Width		Radial run-out
		dm. Deviations		d Deviations		B Deviations		
over	incl.	high	low	high	low	high	low	max.
18	30	+21	0	+25	-4	0	-120	18
30	50	+25	0	+30	-5	0	-120	20

**SP**

### Designation example

SP — Housing type  
 204 — Size

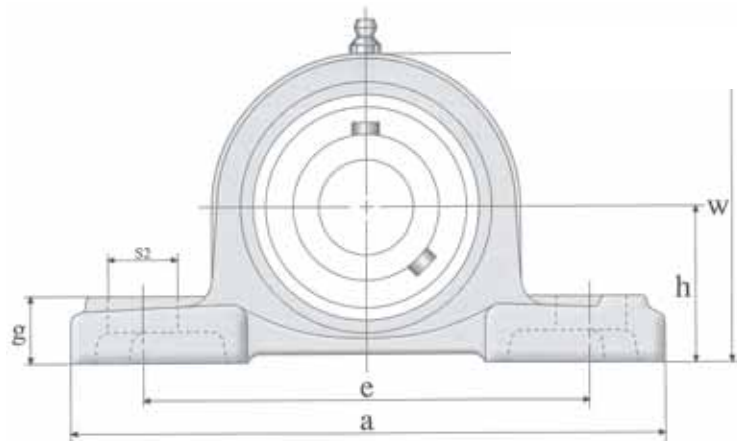
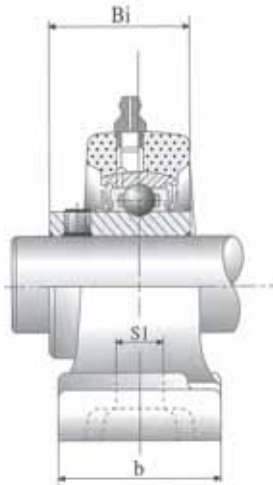

Stainless Steel units

Housing number	Shaft diameter	Dimensions (mm)										Weight (Kg.)	Bolt size
		mm.	Da	h	a	e	b	S1	S2	g	w		
SP204	20	47	33,3	126	95	38	11	17,5	15,1	65,1	31	0,9	M10
SP205	25	52	36,5	140	105	38	12,5	17,5	16	70	34,1	0,95	M10
SP206	30	62	42,9	165	121	48	14,3	21	18	83	38,1	1,6	M14
SP207	35	72	47,6	167	127	48	14,3	22	19	94	42,9	1,9	M14
SP208	40	80	49,2	184	136,5	54	14,3	22	19	100	49,2	2,4	M14
SP209	35	85	54,0	190	146	54	15	22	20	109	49,2	2,7	M14
SP210	40	90	57,2	206	159	60	18	24	22	114	51,6	3,1	M16

– Stainless Steel pillow blocks.

### Designation example

SF — Housing type  
 204 — Size

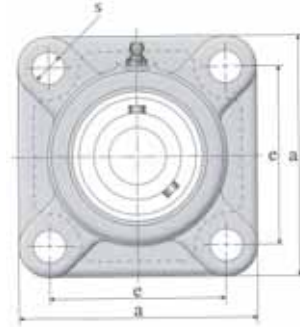

SF

Housing number	Shaft diameter mm.	Dimensions (mm)								Weight (Kg.)	Bolt size mm.
		Da	a	e	i	l	g	s	Bi		
SF204	20	47	86	63,5	15,1	25,4	12	11	33,4	0,63	M10
SF205	25	52	95	70	15,9	27	14	11,5	35,7	0,85	M10
SF206	30	62	108	82,5	17,9	30	14	13,1	40,1	1,17	M14
SF207	35	72	117,5	92	19,1	33	14,3	13,1	44,5	1,51	M14
SF208	40	80	130	101,6	21	36	14,3	14	51,2	2	M14
SF209	45	85	137	104,8	21,8	38	14,3	16	52	2,2	M16
SF210	50	90	143	111	21,8	39	15,1	16	54,4	2,4	M16

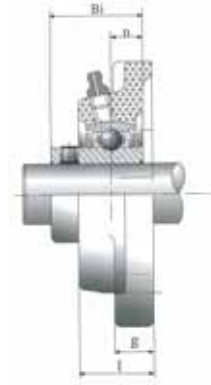

– Stainless Steel 4-hole flange.

### Designation example

SFL — Housing type  
 204 — Size

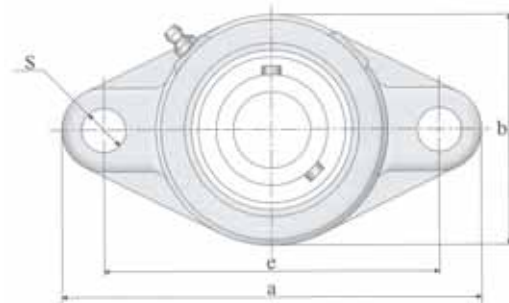

SFL

Housing number	Shaft diameter mm.	Dimensions (mm)									Weight (Kg.)	Bolt size mm.
		Da	a	e	i	b	l	g	s	Bi		
SFL204	20	47	112	90	15,1	60	25,4	11,5	10	31	0,5	M10
SFL205	25	52	125	99	15,9	68	27	13	12	34,1	0,65	M14
SFL206	30	62	141	117	17,9	80	30	13	12	38,1	0,9	M14
SFL207	35	72	155,5	130	19,1	90	33	14,3	13	42,9	1,2	M14
SFL208	40	80	171,5	144	21	100	36	14,3	13	49,2	1,6	M14
SFL209	45	85	179	148	21,8	108	37	14,3	15	49,2	1,8	M16
SFL210	50	90	189	157	21,8	115	38	15,1	15	51,6	2,1	M16

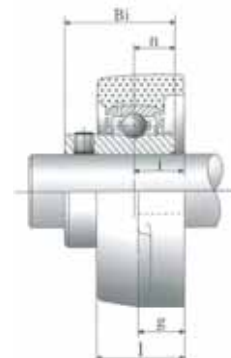

– Stainless Steel 2-hole flange.

# Stainless Steel bearing insert

MUC

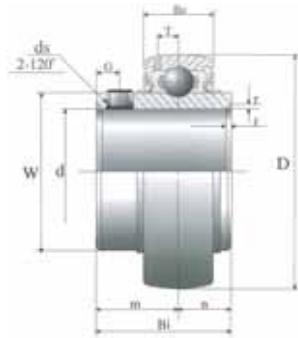

### Designation example

MUC — ANB insert  
206 — Size

Housing number	Shaft diameter mm.	Dimensions (mm)										Weight (Kg.)	Basic load rating (n)	
		D	Bi	Be	r	n	m	G	ds	T	W		Dynamic Cr	Static Cor
*MUC201	12	47	31	17	1	12,7	18,3	4,5	M6X0,75	4,5	29	0,21	10900	5300
*MUC202	15	47	31	17	1	12,7	18,3	4,5	M6X0,75	4,5	29	0,19	10900	5300
*MUC203	17	47	31	17	1	12,7	18,3	4,5	M6X0,75	4,5	29	0,18	10900	5300
MUC204	20	47	31	17	1	12,7	18,3	4,5	M6X0,75	4,5	29	0,15	10900	5300
MUC205	25	52	34	17	1,5	14,3	19,8	8	M6X0,75	4,5	34	0,19	11900	6300
MUC206	30	62	38,1	19	1,5	15,9	22,2	5	M6X0,75	5,1	40,5	0,31	16700	9050
MUC207	35	72	42,9	20	2	17,5	25,4	6	M8X1	5,8	48	0,48	22000	12300
MUC208	40	80	49,2	21	2	19	30,2	8	M8X1	6,2	53	0,62	24900	14300
MUC209	45	85	49,2	22	2	19	30,2	8	M8X1	6,5	57,3	0,67	28100	16400
MUC210	50	90	51,6	23	2	19	32,6	9	M810X1,25	6,5	63	0,78	30200	18600

\* Available in 40 OD.

MB

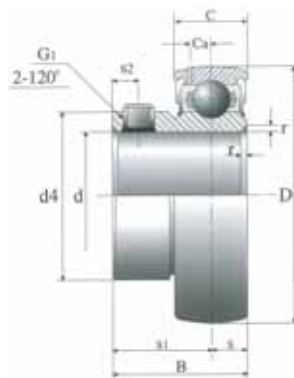

### Designation example

MB — ANB insert  
204 — Size

Housing number	Shaft diameter mm.	Dimensions (mm)											Weight (Kg.)	Basic load rating (n)	
		d	D	B	C	r	s	s1	s2	G1	Ca	d4		Dynamic Cr	Static Cor
MB204	20	20	47	24,7	14	1,5	7	17,7	4,5	M5X0,80	4,1	29	0,125	10900	5300
MB205	25	25	52	27	15	1,5	7,5	19,5	5	M6X0,75	4,1	34	0,160	11900	6300
MB206	30	30	62	30,3	16	1,5	8	22,3	5	M6X0,75	4,9	40,5	0,250	16700	9000
MB207	35	35	72	32,9	17	2	8,5	24,4	6	M8X1	5,4	48	0,380	22000	12300
MB208	40	40	80	35,5	18	2	9	26,5	8	M8X1	5,9	53	0,490	24900	14300

Special for use with back seal.

**Designation example**  
 UC — ANB insert  
 208 — Size

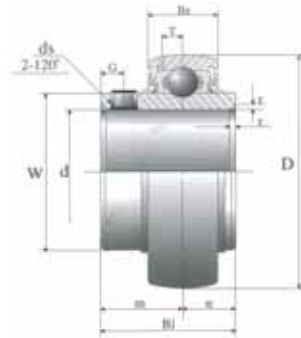

UC

Housing number	Shaft diameter	Dimensions (mm)										Weight	Basic load rating (n)	
		D	Bi	Be	r	n	m	G	ds	T	W		Dynamic Cr	Static Cor
	mm.											(Kg.)	mm.	
UC201	12	47	31	17	1	12,7	18,3	4,5	M6X0,75	4,5	29	0,20	12850	6670
UC202	15	47	31	17	1	12,7	18,3	4,5	M6X0,75	4,5	29	0,18	12850	6670
UC203	17	47	31	17	1	12,7	18,3	4,5	M6X0,75	4,5	29	0,18	12850	6670
UC204	20	47	31	17	1	12,7	18,3	4,5	M6X0,75	4,5	29	0,16	12850	6670
UC205	25	52	34	17	1,5	14,3	19,8	5	M6X0,75	4,5	34	0,19	14028	7848
UC206	30	62	38,1	19	1,5	15,9	22,2	5	M6X0,75	5,1	40,5	0,30	19620	11280
UC207	35	72	42,9	20	2	17,5	25,4	6	M8X1	5,8	48	0,48	25898	15400
UC208	40	80	49,2	21	2	19	30,2	8	M8X1	6,2	53	0,62	29330	17950
UC209	45	85	49,2	22	2	19	30,2	8	M8X1	6,5	57,3	0,67	32860	20500
UC210	50	90	51,6	23	2	19	32,6	9	M810X1,25	6,5	63	0,78	35315	23249

## Plastic insert - under water units

- No maintenance
- Chemical resistant
- Easily cleaned smooth surface

### Material

- PNS: Delrin
- UC200P: Acetal and 316
- Stainless Steel balls



Plastic Insert

Capacity versus Speed

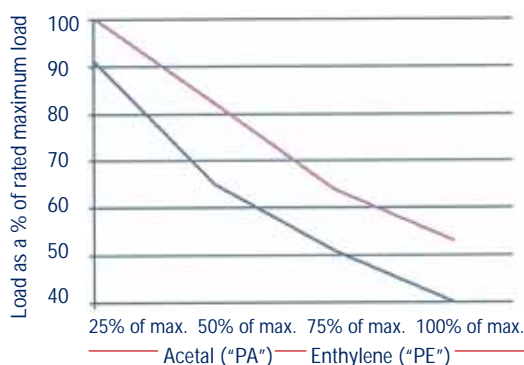

Capacity versus Temperature

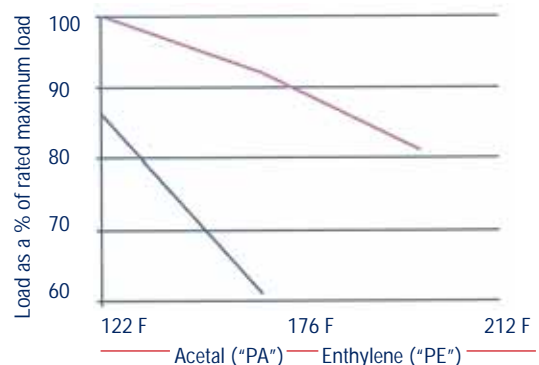

# Plastic insert - under water units

## UCP

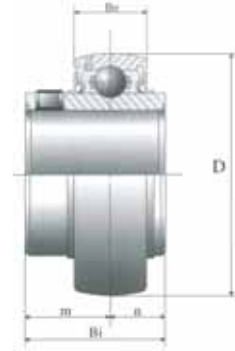

Housing number	d	D	Bi	Be	m	n	Load capacity single row (N)		max. speed single row
	mm.	mm.	mm.	mm.	mm.	mm.	stat.	dyn	rpm
UC200P	10	47	31,0	17	18,3	12,7	270	420	1050
UC201P	12	47	31,0	17	18,3	12,7	270	420	1050
UC202P	15	47	31,0	17	18,3	12,7	270	420	1050
UC203P	17	47	31,0	17	18,3	12,7	270	420	1050
UC204P	20	47	31,0	17	18,3	12,7	270	420	1050
UC205P	25	52	34,1	17	19,6	14,5	320	480	950
UC206P	30	62	38,1	19	22,2	15,9	360	550	800
UC207P	35	72	42,9	20	25,4	17,5	410	620	700
UC208P	40	80	49,2	21	30,2	19,0	440	660	326
UC209P	45	85	49,2	22	30,2	19,0	470	720	580

## PNS

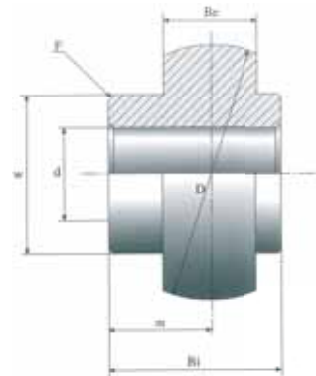

Housing number	Dimensions (mm)							
	d	tol.	D	Bi	m	Be	w	F
PNS201	12		47	31	18,3	17	29	1,5
PNS202	15	+0,03	47	31	18,3	17	29	1,5
PNS203	17	+0,06	47	31	18,3	17	29	1,5
PNS204	20		47	31	18,3	17	29	1,5
PNS205	25	+0,04	52	34	19,7	17	34	1,5
PNS206	30	+0,08	62	38,1	22,2	19	40,5	1,5
PNS207	35	+0,05	72	42,9	25,4	20	48	1,5
PNS208	40	+0,10	80	49,2	30,2	21	53	1,5
PNS209	45	+0,06	85	49,2	30,2	22	57,3	1,5
PNS210	50	+0,12	90	51,6	32,6	23	63	1,5

Plastic bearing insert

An obvious complimentary product to conveyor building is the side guard brackets, return rollers, hinges, photo-cell holders and clamps etc.

We offer a wide range of products from stock in reinforced polyamide quality, for effective, time- and cost- saving, design related tasks. All the components are made from the philosophy that they should be Easy-To-Use and Easy-To-Clean.

***Apart from the numerous standard wear profiles found in the following pages, we also offer to produce special curves, tracks or wear parts from our own workshop.***



# Support bases

TRIPOD

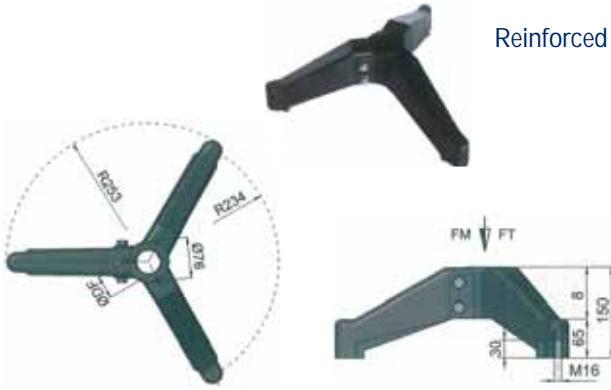

Reinforced polyamide, bushings in nickel plated brass, screws according to table.

DF		mm	inch	SS	FM N (Newton)	FD N (Newton)	FT N (Newton)	Kg	COD.
mm	inch								
42,4	1 ¼				16000	-	8000	1,90	8310005
48,3	1 ½				16000	-	8500	1,90	8310008
50,9	-				16000	-	9000	1,90	8310010
60,3	2				16000	-	10000	1,90	8310012

BIPOD

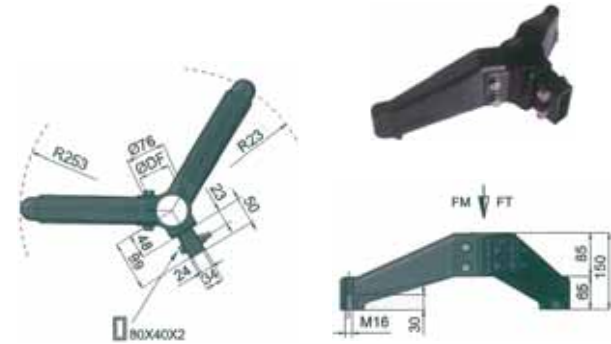

DF		mm	inch	SS	FM N (Newton)	FD N (Newton)	FT N (Newton)	Kg	COD.
mm	inch								
42,4	1 ¼				13000	-	7500	1,70	8310023
48,3	1 ½				13000	-	8000	1,60	8310024
50,9	-				13000	-	8500	1,60	8310025
60,3	2				13000	-	9000	1,60	8310026

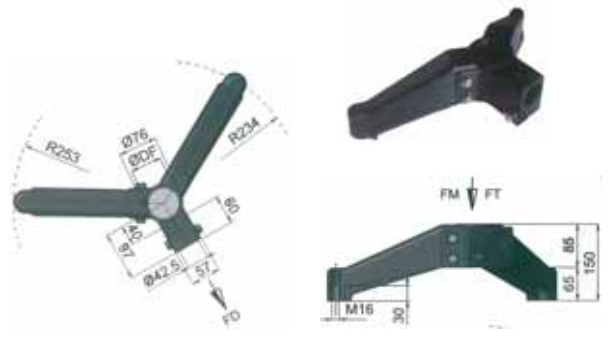

DF		mm	inch	SS	FM N (Newton)	FD N (Newton)	FT N (Newton)	Kg	COD.
mm	inch								
42,4	1 ¼				13000	7500	7500	1,60	8310037
48,3	1 ½				13000	7500	8000	1,60	8310038
50,9	-				13000	7500	8500	1,60	8310039
60,3	2				13000	7500	9000	1,60	8310040

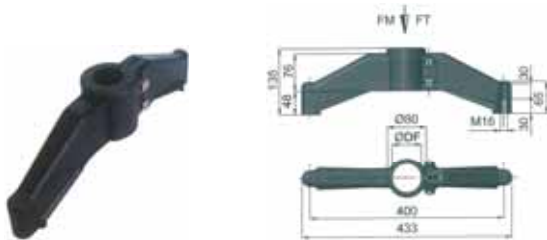

DF		mm	inch	SS	FM N (Newton)	FD N (Newton)	FT N (Newton)	Kg	COD.
mm	inch								
42,4	1 ¼				12000	-	8000	1,03	8310057
48,3	1 ½				12000	-	8500	1,01	8310058
50,9	-				12000	-	9000	0,99	8310059
60,3	2				12000	-	10000	0,97	8310060



DF		mm	inch	SS	FM N (Newton)	FD N (Newton)	FT N (Newton)	Kg	COD.
mm	inch								
48,3	1 ½				13000	4500	8000	1,60	8310061
50,9	-				13000	4500	8500	1,40	8310062
60,3	2				13000	4500	9000	1,19	8310063

Support bases



# Threated tube ends

Reinforced polyamide, bushings in nickel plated brass.

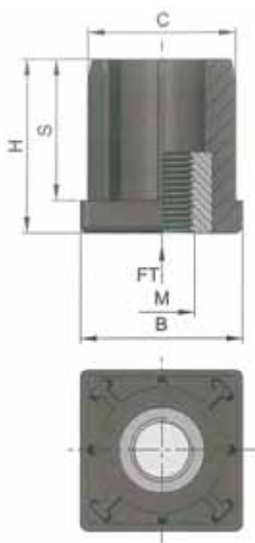

TUBE ENDS

FT: Max. static load.

M	B	C	H	S	Square tubes			FT N (Newton)	Kg	COD.
					EXT.	INT.	Thickness			
8	25	22,5	30	25	25	22	1,5	5000	0,04	1482201
10									0,04	1482205
12									0,04	1482209
10	30	27,5	33	27	30	27	1,5	5500	0,04	1482211
12									0,04	1482212
14									0,04	1482213
16									0,04	1482214
10	30	26,5	33	27	30	26	2	5500	0,04	1482215
12									0,04	1482216
14									0,04	1482217
16									0,04	1482218
10	35	32,5	43	35	35	32	1,5	5500	0,04	1482221
12									0,04	1482222
14									0,04	1482223
16									0,04	1482224
20									0,04	1482225
10	38	35,4	43	35	38,1	34,9	1,6	6000	0,05	1482230
12									0,05	1482231
14									0,05	1482232
16									0,05	1482233
20									0,05	1482234
10	40	37,5	43	35	40	37	1,5	6000	0,05	1482240
12									0,05	1482241
14									0,06	1482242
16									0,06	1482243
20									0,06	1482244
10	40	36,5	43	35	40	36	2	6000	0,06	1482247
12									0,06	1482248
14									0,06	1482249
16									0,06	1482250
20									0,06	1482251
12	50	47,5	55	44	50	47	1,5	10000	0,10	1482254
14									0,10	1482255
16									0,10	1482256
20									0,10	1482257
12	50	46,5	55	44	50	46	2	10000	0,10	1482265
14									0,10	1482266
16									0,10	1482267
20									0,10	1482268
12	50	45,5	55	44	50	45	2,5	10000	0,10	1482309
14									0,10	1482311
16									0,10	1482314
20									0,10	1482318
14	60	56,5	55	45	60	56	2	12000	0,14	1482270
16									0,14	1482271
20									0,14	1482272

Threated tube ends

# Threated tube ends

Reinforced polyamide, bushings in nickel plated brass.

TUBE ENDS



FT: Max. static load

M	B	C	H	S	Round tubes			FT N (Newton)	Kg	COD.
					EXT.	INT.	Thickness			
10	38	35,5	43	34	38	35	1,5	5000	0,05	1483360
12									0,05	1483361
14									0,05	1483362
16									0,05	1483363
10	42	39,9	42	34	42,4	39,4	1,5	6000	0,07	1483365
12									0,07	1483366
14									0,07	1483367
16									0,07	1483368
20								0,07	1483369	
12	48	45,8	49	38	48,3	45,3	1,5	6000	0,09	1483380
14									0,09	1483381
16									0,09	1483382
20									0,09	1483383
12	48	45	49	38	48,3	44,3	2	6000	0,09	1483384
14									0,09	1483385
16									0,09	1483386
20									0,09	1483387
16	60	56,7	54,5	44,5	60,3	56,3	2	8000	0,10	1483390
20									0,10	1483391
24									0,10	1483392
16	60	56	54,5	44,5	60,3	55,3	2,5	8000	0,10	1483405
20									0,10	1483406
24									0,10	1483407

# Side mounting top brackets

Reinforced polyamide + fastener in stainless steel.  
\* To use this hole break the diaphragm.

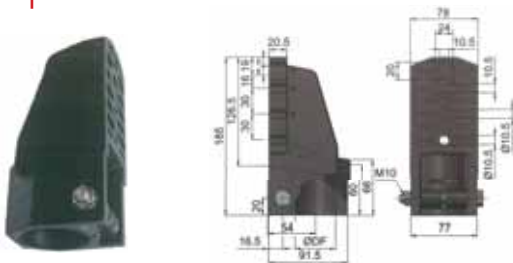

DF		FT N (Newton)	Kg	COD.
mm	inch			
48,3	1 ½	4000	0,58	8330119
60,3	2		0,58	8330121

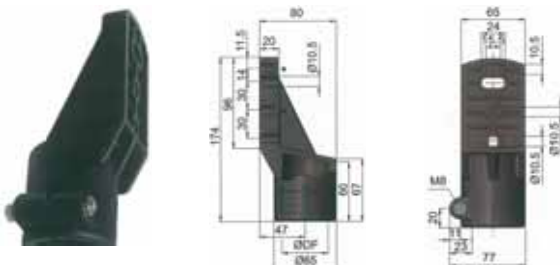

DF		FT N (Newton)	Kg	COD.
mm	inch			
48,3	1 ½	3500	0,36	8330125
50,9	-			8330126

Threated tube ends  
Side mounting top brackets

## Side mounting top brackets

Reinforced polyamide + fastener in stainless steel.

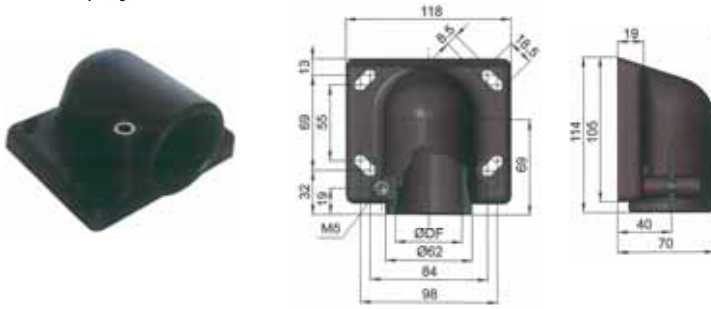

TOP  
BRACKETS

DF		FT N (Newton)	Kg	COD.
mm	inch			
48,3	1 ½	3500	0,34	8330135

## Connecting joints

CONNECTING  
JOINTS

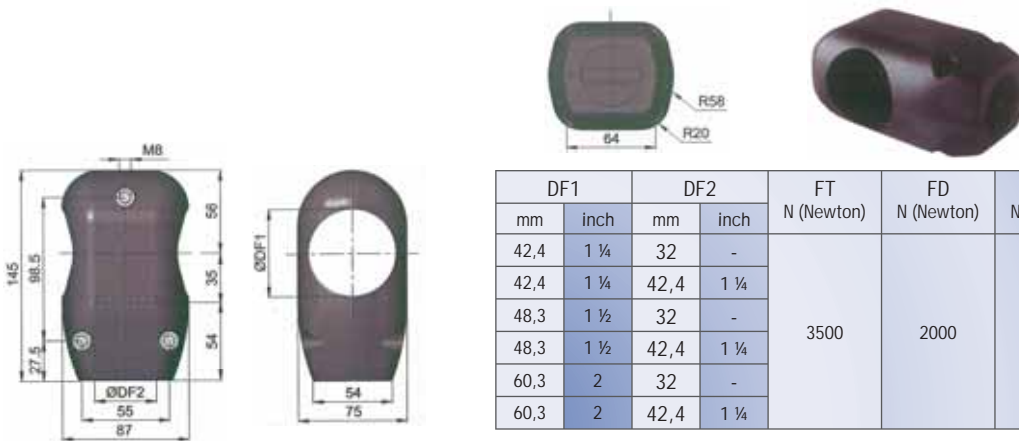

DF1		DF2		FT N (Newton)	FD N (Newton)	FM N (Newton)	Kg	COD.
mm	inch	mm	inch					
42,4	1 ¼	32	-	3500	2000	-	0,40	8330045
42,4	1 ¼	42,4	1 ¼				0,40	8330046
48,3	1 ½	32	-				0,40	8330047
48,3	1 ½	42,4	1 ¼				0,40	8330048
60,3	2	32	-				0,39	8330049
60,3	2	42,4	1 ¼				0,39	8330050

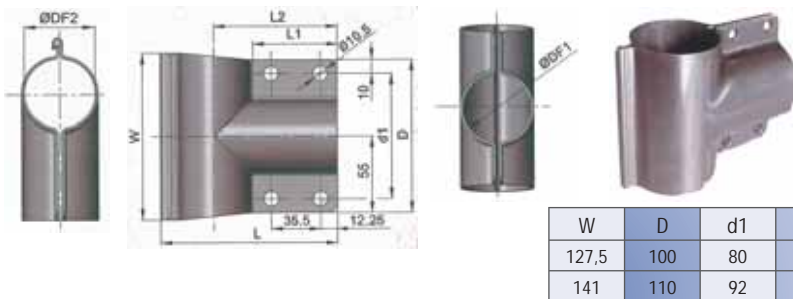

W	D	d1	L	L1	L2	DF1	DF2	Kg	COD.
127,5	100	80	120	64,2	88,5	48,3	48,3	0,52	8360501
141	110	92	136	64,8	95	60,3	60,3	0,68	8360530

## Support heads

SUPPORT  
HEADS



Reinforced polyamide + fastener in stainless steel.

DF		FT N (Newton)	Kg	COD.
mm	inch			
42,4	1 ¼	2000	0,35	8330052
48,3	1 ½		0,35	8330053
50,9	-		0,35	8330054
60,3	2		0,34	8330055

Side mounting top brackets  
Connecting joints, Support heads

## Support heads

Reinforced polyamide + fastener in stainless steel.

SUPPORT HEADS

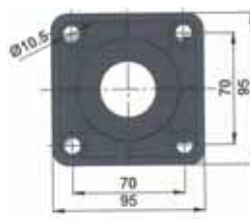
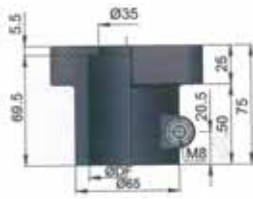

DF		FT N (Newton)	Kg	COD.
mm	inch			
48,3	1 ½	1500	0,30	8330112
50,9	-		0,30	8330114

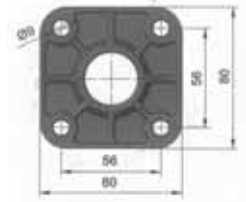
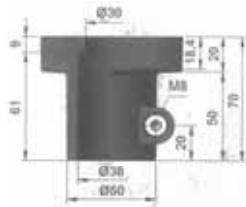

FT N (Newton)	Kg	COD.
1200	0,17	8330082

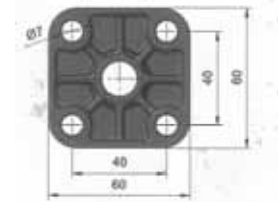
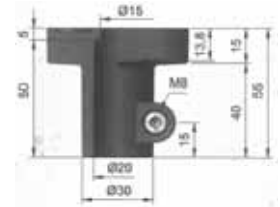

FT N (Newton)	Kg	COD.
800	0,07	8330071

SPLIT COLLARS

## Split collars

Reinforced polyamide + fastener in stainless steel.

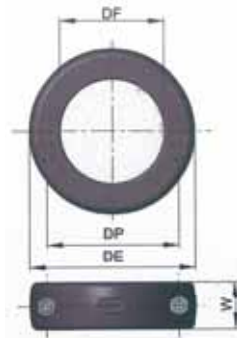

DF	DE	DP	W	Kg	COD.
10	30	20	12	0,01	8235324
12	30	20	12	0,01	8235325
14	30	20	12	0,01	8235327
15	39	27	14	0,02	8235329
16	39	27	14	0,02	8235331
18	39	27	14	0,02	8235334
20	40	29	14	0,02	8235350
25	45	35	14	0,02	8235351
30	55	45	16	0,03	8235352
35	60	47	16	0,03	8235353
40	64	51	18	0,04	8235354



# Accessories

Reinforced polyamide, bush in nickel plated brass.

M	Kg	COD.
M8	0,03	1485470
M10		1485495

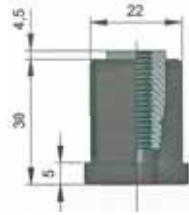

Reinforced polyamide, fastener in stainless steel.

Kg	COD.
0,03	1485540

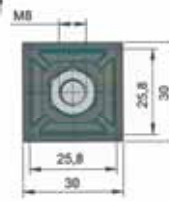

Accessories

M	Kg	COD.
M8	0,02	1486505
M10		1486526



Kg	COD.
0,06	1486571



Reinforced polyamide, fastener in stainless steel.

DE1	DE2	Kg	COD.
38	38	0,07	1486620
	48	0,08	1486625
	60	0,09	1485536



Reinforced polyamide, fastener in stainless steel.

Kg	COD.
0,28	7645301



# Return profile support

RETURN PROFILE SUPPORT

Self-lubricating polyethylene

Kg	COD.
0,04	8025601

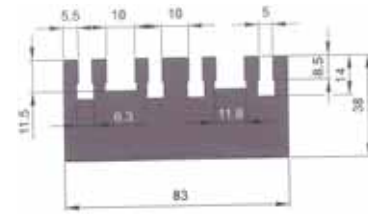

Kg	COD.
0,04	8025630

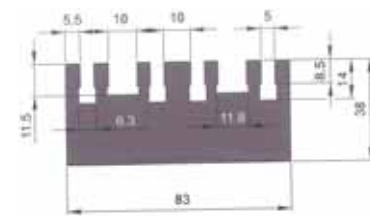

Accessories/  
Return profile support

## Return profile support

UHMW 1000 "DESLIDUR" Polyethylene.

RETURN PROFILE SUPPORT

Colour	L	Kg/m	COD.
Green	25	0,10	P20240

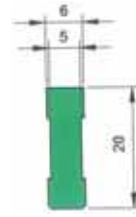

Self-lubricating polyethylene.

Kg	COD.
0,04	8025615

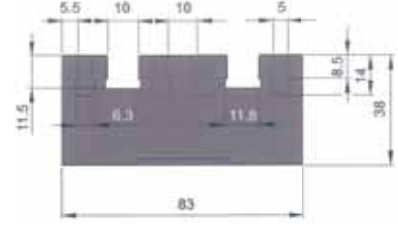

Kg	COD.
0,04	8025621

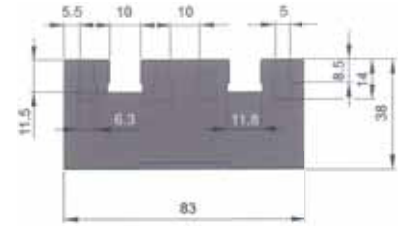

## Return accessories

RETURN Accessories

Self-lubricating polyethylene.

Kg	COD.
0,01	8025645

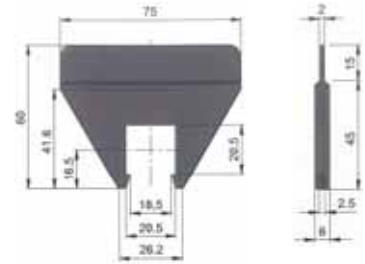

Kg	COD.
0,01	8025650

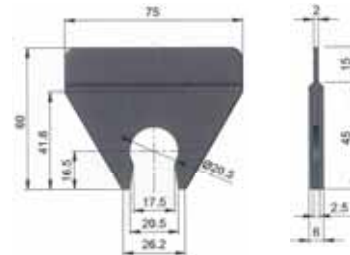

## Chain return components

Self-lubricating polyethylene.



Kg	COD.
0,12	8025104

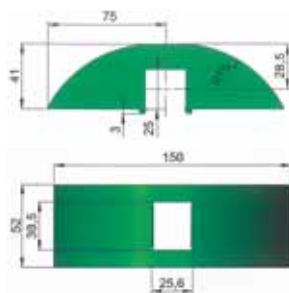

Self-lubricating polyethylene.



Kg	COD.
0,07	8025105

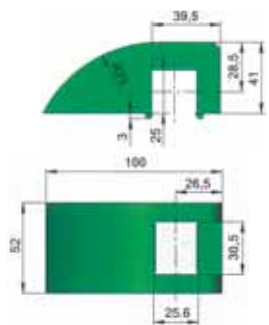

Return profile support, Return accessories, Chain return components.

# Chain return components

Self-lubricating polyethylene.

Kg	COD.
0,09	8025101



**DOUBLE SLIDING**

Kg	COD.
0,15	8025140

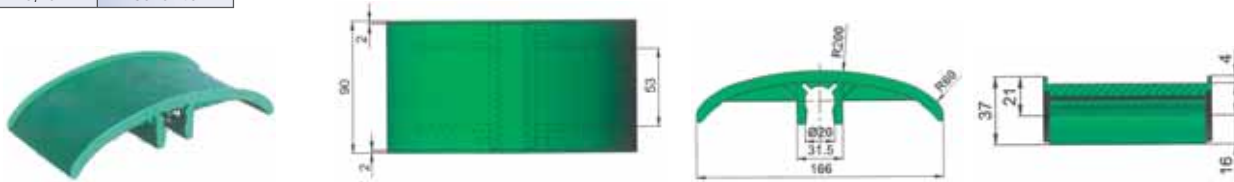

**OSCILLATING SLIDING SHOE**

Colour	Kg/m	COD.
Green	0,14	8025102V
Black		8025102N

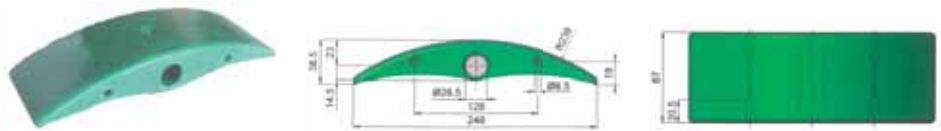

**CLIP-ON OSCILLATING SLIDING SHOE**

Kg	COD.
0,13	8025103



## Return rollers

**RETURN ROLLERS**

Self-lubricating polyamide.

DF	Kg	COD.
12,2	0,03	8010024
16,2	0,03	8010026
18,2	0,03	8010027
20,2	0,03	8010028



DF	Kg	COD.
12,2	0,03	8010235
16,2	0,03	8010237
18,2	0,03	8010238
20,2	0,03	8010239

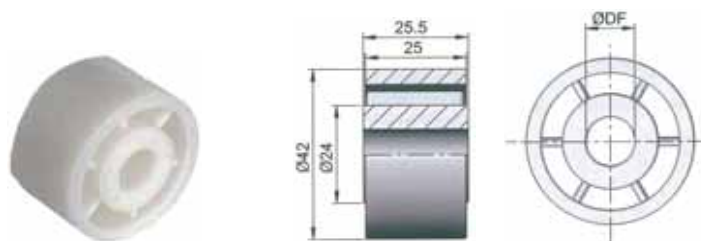

DF	Kg	COD.
12,2	0,03	8010201
16,2	0,03	8010202
18,2	0,03	8010203
20,2	0,03	8010204

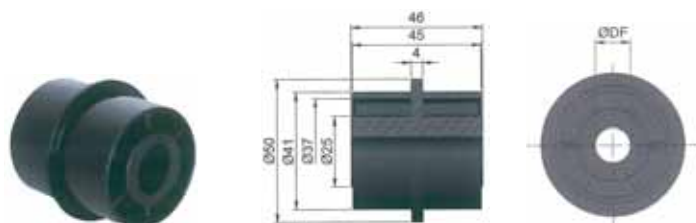

Chain return component:  
Return rollers

Self-lubricating polyamide.

**ROLLERS**

DF	Kg	COD.
12,2	0,03	8010211
16,2	0,03	8010212
18,2	0,03	8010214
20,2	0,03	8010215

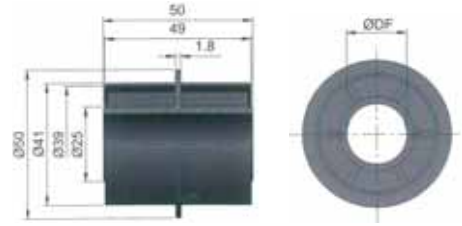

D1	DF	Kg	COD.
18	12,2	0,05	8010230
24,2	20,2	0,05	8010241

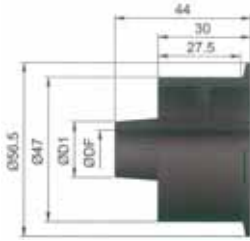

D1	DF	Kg	COD.
18	12,2	0,05	8010234
24,2	20,2	0,05	8010231

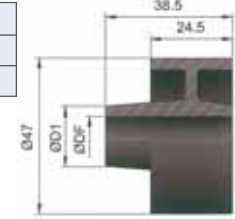

DF	Kg	COD.
20,2	0,06	8010232

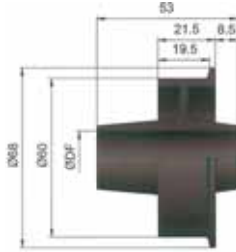

DF	Kg	COD.
20,2	0,06	8010233

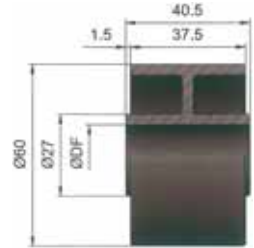

DF	Kg	COD.
20,2	0,06	8010236

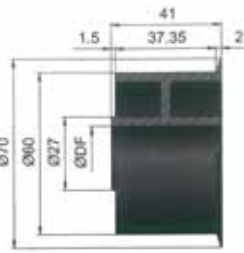

DF	Kg	COD.
12,2	0,07	8010271

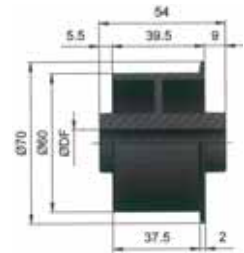

DF	W	Kg	COD.
12,2	31	0,01	8010114
16,2		0,01	8010115
18,2		0,01	8010116
20,2		0,01	8010117
12,2	39	0,01	8010106
16,2		0,01	8010107
18,2		0,01	8010108
20,2		0,01	8010109

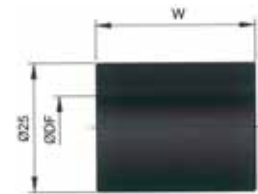

Rollers

Self-lubricating polyethylene.

DE	DF	Kg	COD.
40	20,2	0,04	8010315
60	20,2	0,06	8010340

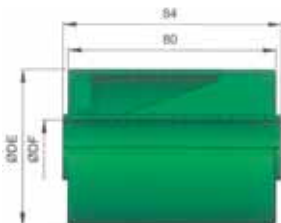

Self-lubricating polyethylene.

DE	DF	Kg	COD.
70	20,2	0,01	8015250

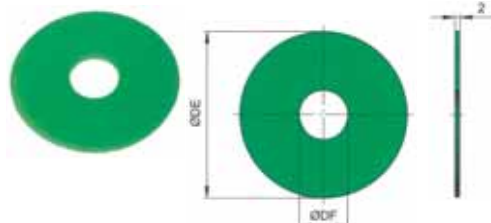



## Self-lubricating polyamide.

DF	W	Kg	COD.
12,2	84	0,09	8010221
14,2		0,09	8010220
16,2		0,09	8010222
18,2		0,09	8010223
20,2		0,09	8010224

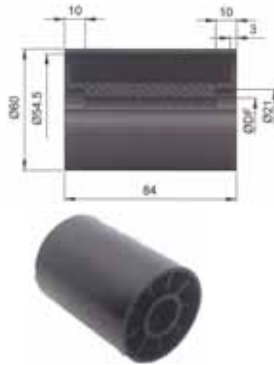

## ROLLERS

DF	W	Kg	COD.
12,2	-	0,01	8015225
16,2		0,01	8015226
18,2		0,01	8015227
20,2		0,01	8015228

DE	DF	W	Kg	COD.
22	11,1	13	0,01	8010022
30	11,1	13	0,01	8010023

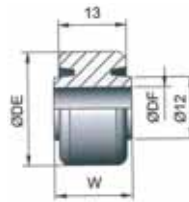
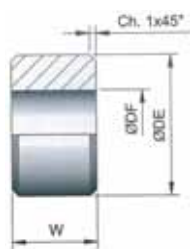

DE	DF	W	Kg	COD.
22	8,2	15	0,01	8010055
22	6,5	17	0,01	8010032
30	8,2	15	0,01	8010057



DE	DF	W	Kg	COD.
22	6,3	25	0,01	8010035

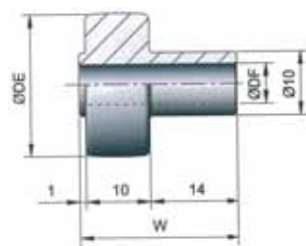

## Reinforced polyamide.

- WITHOUT BEARING - To use (\*)

*	DE	K	M	D	Kg	COD.
6002	50	32	29	47	0,02	8010401

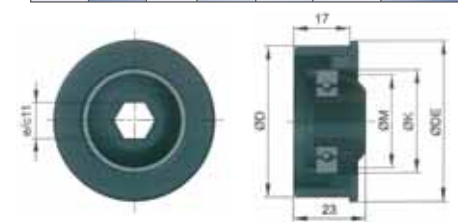

- WITHOUT BEARING - To use (\*)

*	DE	K	M	D	Kg	COD.
6002	50	32	29	47	0,02	8010416
6202	60	35	32	57	0,03	8010420
6302	70	42	39	67	0,04	8010429

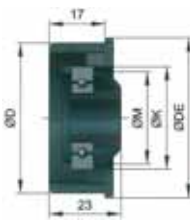
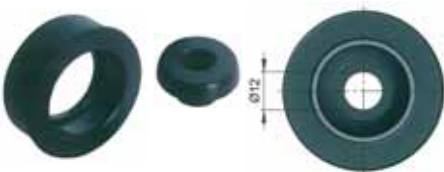

## Self-lubricating acetal, fasteners in stainless steel.

RM	Kg	COD.
400	0,13	8427104

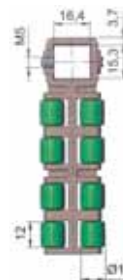

Kg	COD.
0,05	8427190

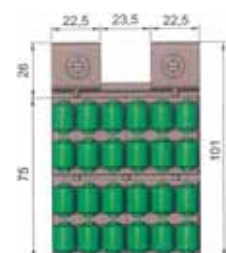
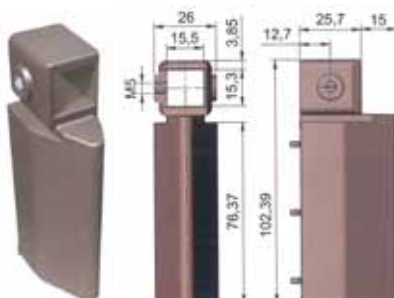
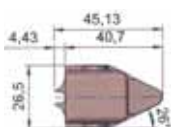

# Transfers

Stainless steel.

PLIERS

Kg	COD.
0,50	8427160

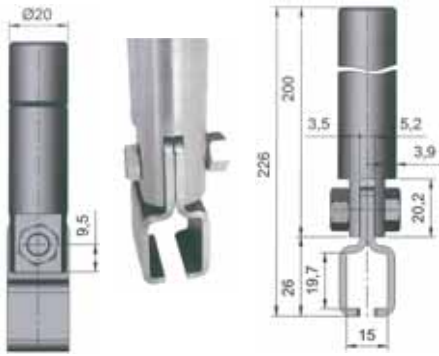

Kg	COD.
0,04	8427165



Self-lubricating acetal, fasteners in stainless steel.

TRANSFER MODULE

Kg	COD.
0,05	8429412

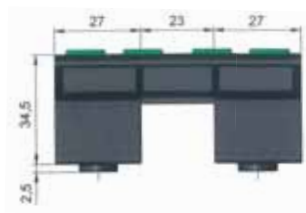
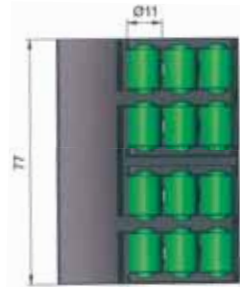
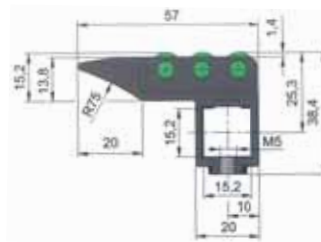

Reinforced polyamide, fasteners in stainless steel.

TRANSFER JUNCTION

Kg	COD.
0,03	8429480

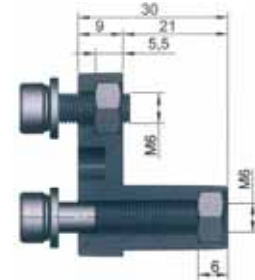
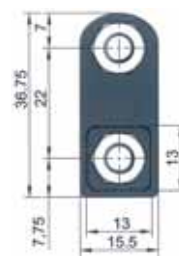

# Roller guides

ROLLER GUIDES

Stainless steel.

DE		LT	Kg	COD.
12	10	104	0,11	8220801
14	12	104	0,14	8220505
15	12	104	0,16	8220811
16	14	104	0,18	8220819

1pc = 1 spindle + 1 screw + 1 washer

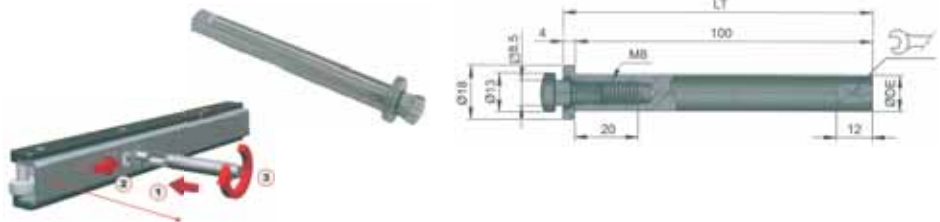

Structure and pin in stainless steel, roller in acetal.

L	Kg	COD.
1000	2,41	8411652
2000	5,80	8412790
3000	8,22	8413877

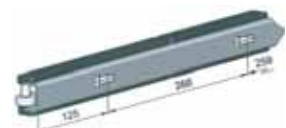
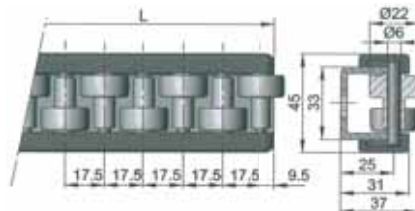

Transfers, Roller guides

Structure and pin in stainless steel, roller in acetal.

## ROLLER GUIDES

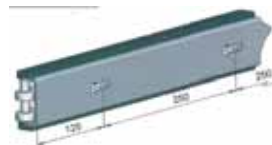
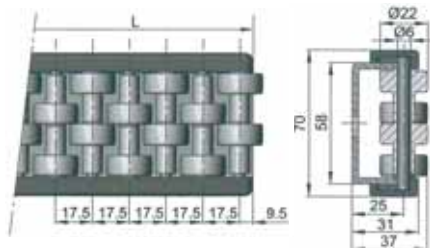

L	Kg	COD.
1000	3,50	8411654
2000	7,00	8412793
3000	10,50	8413879

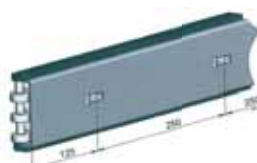
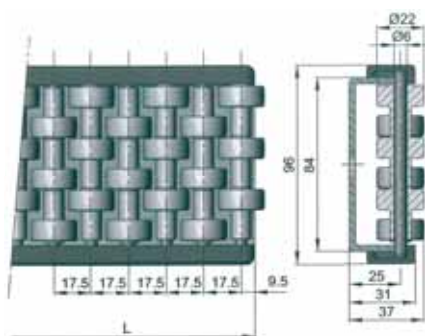

L	Kg	COD.
1000	4,60	8411657
2000	9,20	8412795
3000	13,80	8413881

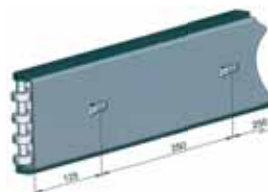
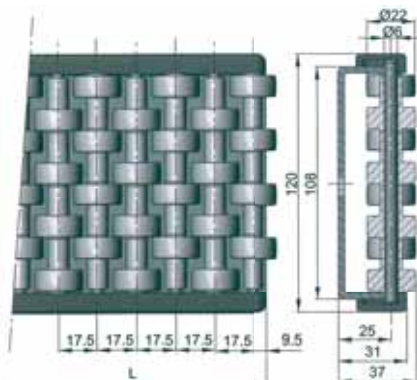

L	Kg	COD.
1000	5,75	8411660
2000	11,50	8412797
3000	17,25	8413883

# Adjustable brackets

## LIGHT BRACKETS

Reinforced polyamide, head eyebolt silver anodized aluminium.

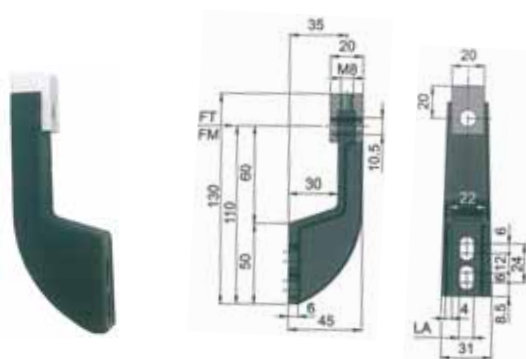
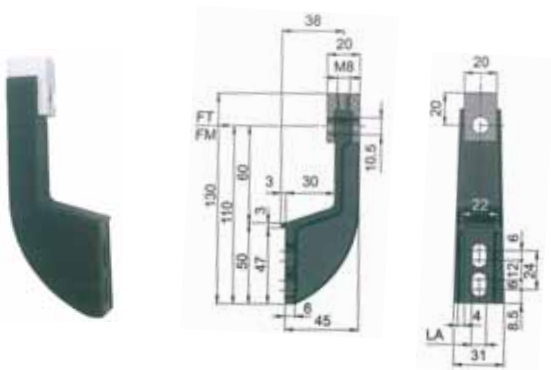

DF	LA	FT N (newton)	FM N (newton)	Kg	COD.
10,5	7	1000	2000	0,06	8110210
10,5	9	1000	2000	0,06	8110212

DF	LA	FT N (newton)	FM N (newton)	Kg	COD.
10,5	7	1000	2000	0,06	8110231
10,5	9	1000	2000	0,06	8110234

Roller guides, Adjustable brackets.

# Adjustable brackets

Reinforced polyamide, head eyebolt silver anodized aluminium and bushings in nickel plated brass.

**LIGHT BRACKETS**

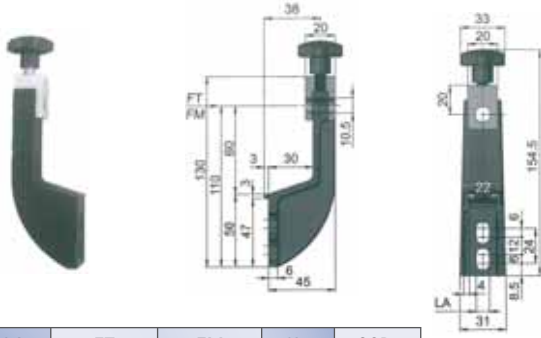

DF	LA	FT N (newton)	FM N (newton)	Kg	COD.
10,5	7	1000	2000	0,08	8110201
10,5	9	1000	2000	0,08	8110205

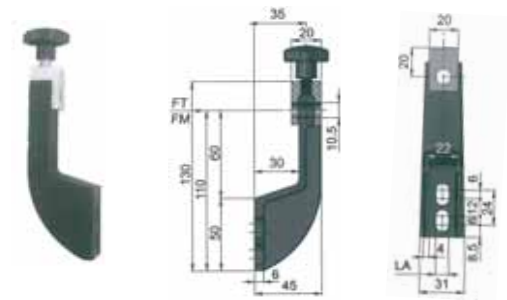

DF	LA	FT N (newton)	FM N (newton)	Kg	COD.
10,5	7	1000	2000	0,08	8110215
10,5	9	1000	2000	0,08	8110221

Reinforced polyamide.

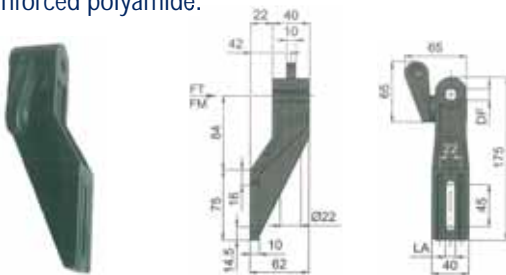

DF	LA	FT N (newton)	FM N (newton)	Kg	COD.
12,2	9	800	3000	0,17	8110012
15,2	9			0,17	8110015

Reinforced polyamide, fastener in stainless steel.

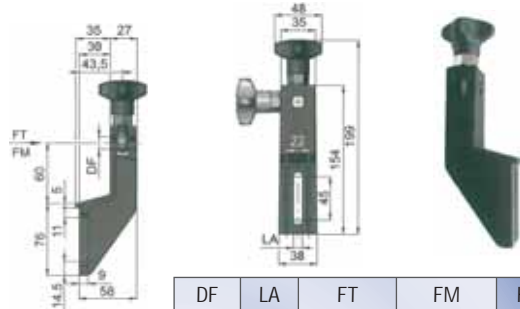

DF	LA	FT N (newton)	FM N (newton)	Kg	COD.
12,5	9	2000	4000	0,21	8110092
14,5		3000		0,21	8110093
16,5		3000		0,21	8110094
12,5	10,5	2000	4000	0,21	8110095
14,5		3000		0,20	8110096
16,5		3000		0,20	8110097

Reinforced polyamide, fastener in stainless steel.

**STANDARD BRACKETS**



DF	LA	FT N (newton)	FM N (newton)	Kg	COD.
12,5	9	2000	4000	0,20	8110030
14,5		3000		0,20	8110031
16,5		3000		0,20	8110032
12,5	10,5	2000	4000	0,20	8110033
14,5		3000		0,20	8110034
16,5		3000		0,20	8110035

Reinforced polyamide, fastener in stainless steel.



DF	LA	FT N (newton)	FM N (newton)	Kg	COD.
12,5	9	2000	5000	0,283	8110018
14,5		3000		0,281	8110019
16,5		3200		0,279	8110020
12,5	10,5	2000	5000	0,283	8110021
14,5		3000		0,281	8110022
16,5		3200		0,279	8110023

Adjustable brackets

**STANDARD  
BRACKETS**

Reinforced polyamide, fastener in stainless steel



DF	LA	FT N (newton)	FM N (newton)	Kg	COD.
12,5	9	2000	5000	0,280	8110024
14,5		3000		0,278	8110025
16,5		3200		0,276	8110026
12,5	10,5	2000	5000	0,280	8110027
14,5		3000		0,278	8110028
16,5		3200		0,276	8110029

Reinforced polyamide.

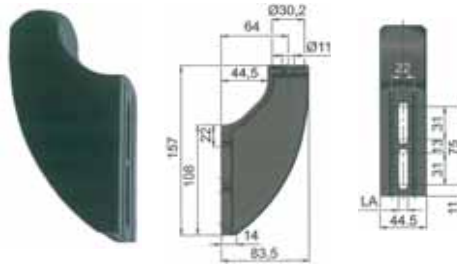

DF	LA	FT N (newton)	FM N (newton)	Kg	COD.
-	9	-	7500	0,17	8115057
-	10,5	-		0,17	8115058

Reinforced polyamide.

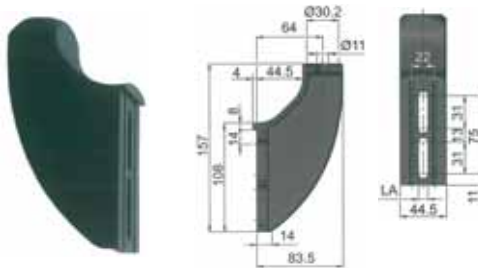

DF	LA	FT N (newton)	FM N (newton)	Kg	COD.
-	9	-	7500	0,18	8115036
-	10,5	-		0,17	8115037

Reinforced polyamide, head eyebolt stainless steel.

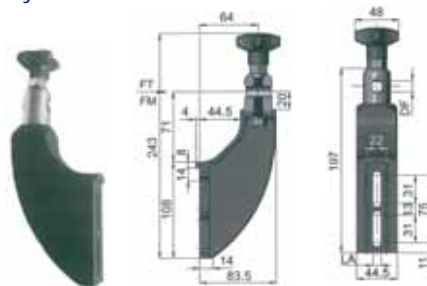

DF	LA	FT N (newton)	FM N (newton)	Kg	COD.
12,5	9	5000	7500	0,49	8115160
14,5		6000		0,47	8115161
16,5		6000		0,44	8115163
12,5	10,5	5000	7500	0,49	8115175
14,5		5000		0,47	8115176
16,5		6000		0,44	8115178

Reinforced polyamide, head eyebolt and bushings in nickel plated brass.



DF	LA	FT N (newton)	FM N (newton)	Kg	COD.
12,5	9	5000	7500	0,49	8115038
14,5		6000		0,47	8115039
16,5		6000		0,44	8115040
12,5	10,5	5000	7500	0,49	8115041
14,5		5000		0,47	8115042
16,5		6000		0,44	8115043

Reinforced polyamide, eyebolt stainless steel and bushings in nickel plated brass.



DF	LA	FT N (newton)	FM N (newton)	Kg	COD.
12,5	9	2600	7500	0,33	8115044
14,5		3500		0,32	8115045
16,5		3500		0,32	8115046
12,5	10,5	2600	7500	0,33	8115047
14,5		3500		0,32	8115048
16,5		3500		0,32	8115049

Adjustable brackets

# Adjustable brackets

Reinforced polyamide, eyebolt stainless steel and bushings in nickel plated brass.

STANDARD BRACKETS

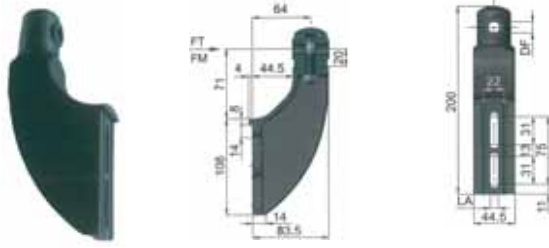

DF	LA	FT N (newton)	FM N (newton)	Kg	COD.
12,5	9	2200	7500	0,20	8115051
14,5		3000		0,20	8115052
16,5		3000		0,20	8115053
12,5	10,5	2200	7500	0,20	8115054
14,5		3000		0,20	8115055
16,5		3000		0,20	8115056

Reinforced polyamide, head eyebolt stainless steel.



DF	LA	FT N (newton)	FM N (newton)	Kg	COD.
12,5	9	5000	7500	0,49	8115185
14,5		6000		0,47	8115186
16,5		6000		0,44	8115187
12,5	10,5	5000	7500	0,49	8115190
14,5		6000		0,47	8115191
16,5		6000		0,47	8115193

Reinforced polyamide, head eyebolt and bushings in nickel plated brass.



DF	LA	FT N (newton)	FM N (newton)	Kg	COD.
12,5	9	5000	7500	0,49	8115059
14,5		6000		0,47	8115060
16,5		6000		0,44	8115061
12,5	10,5	5000	7500	0,49	8115062
14,5		6000		0,47	8115063
16,5		6000		0,47	8115064

Reinforced polyamide, fastener in stainless steel.



DF	LA	FT N (newton)	FM N (newton)	Kg	COD.
12,5	9	2600	7500	0,30	8115065
14,5		3500		0,30	8115066
16,5		3500		0,30	8115067
12,5	10,5	2600	7500	0,30	8115068
14,5		3500		0,30	8115069
16,5		3500		0,30	8115070

Adjustable brackets



DF	LA	FT N (newton)	FM N (newton)	Kg	COD.
12,5	9	2200	7500	0,21	8115071
14,5		3000		0,20	8115072
16,5		3000		0,20	8115073
12,5	10,5	2200	7500	0,21	8115074
14,5		3000		0,20	8115075
16,5		3000		0,21	8115076

# Supports

Stainless steel.

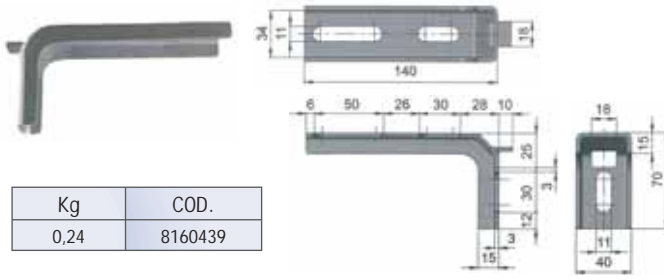

Kg	COD.
0,24	8160439

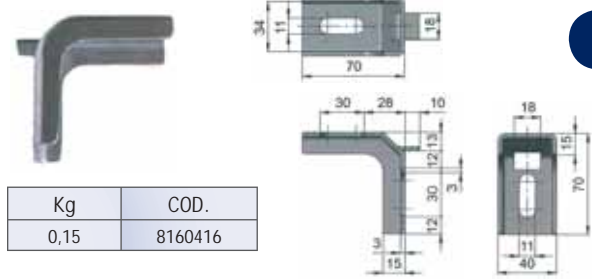

Kg	COD.
0,15	8160416

SUPPORTS

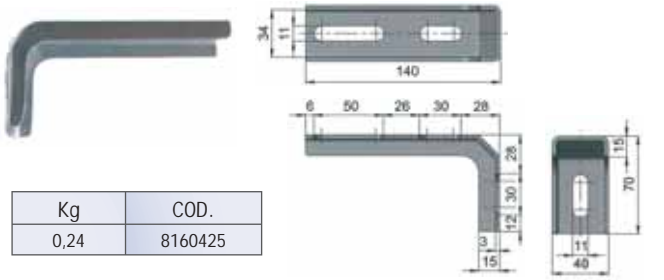

Kg	COD.
0,24	8160425

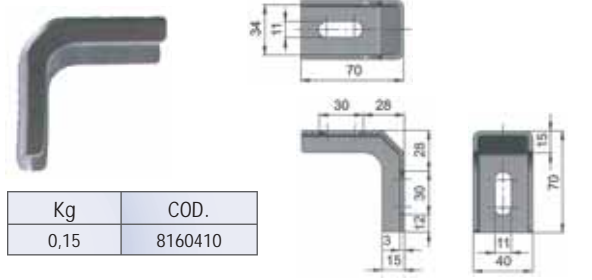

Kg	COD.
0,15	8160410

# Support spacer

SUPPORT SPACER

Reinforced polyamide.

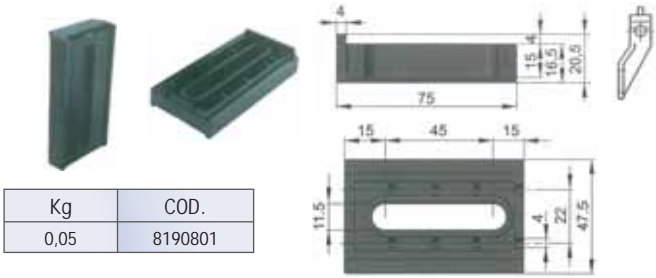

Kg	COD.
0,05	8190801

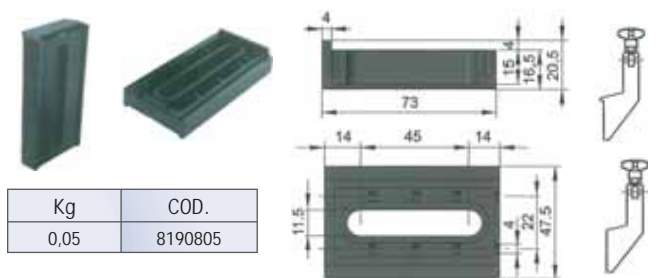

Kg	COD.
0,05	8190805

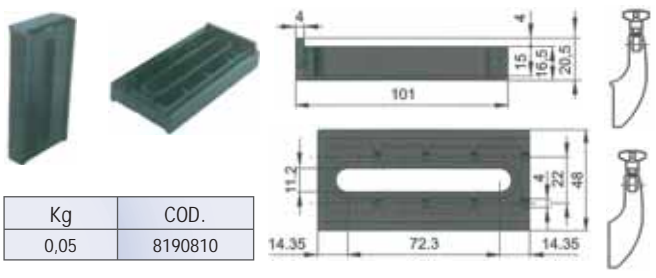

Kg	COD.
0,05	8190810

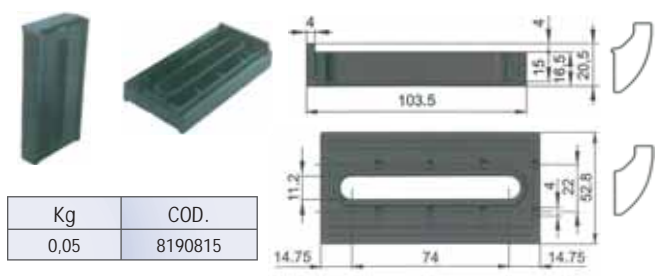

Kg	COD.
0,05	8190815

# Knobs

Reinforced polyamide, bushings in nickel plated brass.

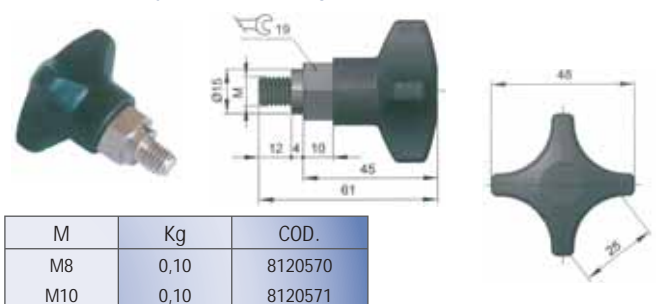

M	Kg	COD.
M8	0,10	8120570
M10	0,10	8120571

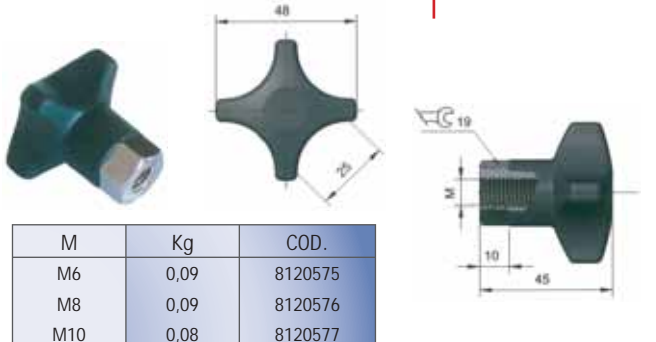

M	Kg	COD.
M6	0,09	8120575
M8	0,09	8120576
M10	0,08	8120577

Supports, Support spacer, Knobs.

# Knobs

Reinforced polyamide, pin in zinc plated steel.

## HANDLES

M	A	B	C	D	E	F	G	H	Kg	COD.
M6	43	50	35	21	12	6	13	25	0,08	8120691
M8	65	73	46	26,5	15	8	17	30	0,08	8120692
M10	83	93	57	33,5	19	10	22	40	0,09	8120693
M12	104	120	69	40	25	11	24	60	0,10	8120694



M	A	B	C	D	E	F	G	H	Kg	COD.
M6	43	50	35	21	12	6	13	-	0,02	8120705
M8	65	73	46	26,5	15	8	17	-	0,02	8120706
M10	83	93	57	33,5	19	10	22	-	0,02	8120707
M12	104	120	69	40	25	11	24	-	0,03	8120708

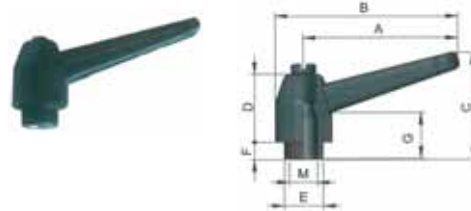

## HEADS

# Heads

DF	Mat.	Kg	COD.
12,5	Reinforced Polyamide	0,08	8120107
14,5		0,08	8120108
16,5		0,08	8120109



DF	Mat.	Kg	COD.
12,5	Reinforced Polyamide	0,08	8120101
14,5		0,08	8120102
16,5		0,08	8120103



DF	Mat.	Kg	COD.
12,5	Nickel plated Brass	0,18	8120122
14,5		0,18	8120123
16,5		0,18	8120124
12,5	Stainless Steel	0,18	8120129
14,5		0,17	8120130
16,5		0,17	8120131

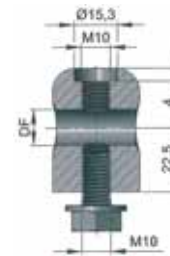

DF	Mat.	H	W	Kg	COD.
12,5	Stainless Steel	40	55	0,28	8120301
		60	75	0,38	8120302
		90	105	0,55	8120303
		130	145	0,77	8120304
14,5		40	56	0,28	8120307
		60	76	0,38	8120308
		90	106	0,55	8120309
		130	146	0,77	8120310
16,5		40	57	0,28	8120315
		60	77	0,38	8120316
		90	107	0,55	8120317
		130	147	0,77	8120318

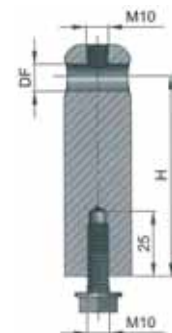

Knobs Heads



Reinforced polyamide.

DF	Kg	COD.
10,5	0,01	8120085

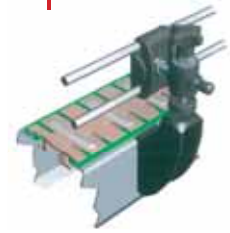
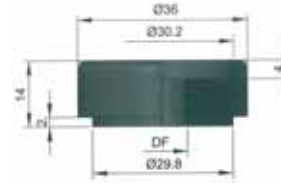

## Adjusting rods

RODS

Flexible PVC. Black colour  
Safety cap.

DF	h	H	Kg	COD.
10	15	18	0,01	7640174
12	16	20	0,01	7640176
15	17	21	0,01	7640179
16	18	23	0,01	7640180
20	20	24,5	0,01	7640181



Spindle not included.

Stainless steel, nut in Stainless steel.



DE	LT	Kg	COD.
12	100	0,09	8220301
12	118	0,11	8220321
12	150	0,13	8220322
14	100	0,12	8220302
15	100	0,14	8220303
16	100	0,16	8220304

For clamps 8210134,  
8210212, 8210525,  
8210270,8210277

Polyethylene. Black colour  
Strip tube.

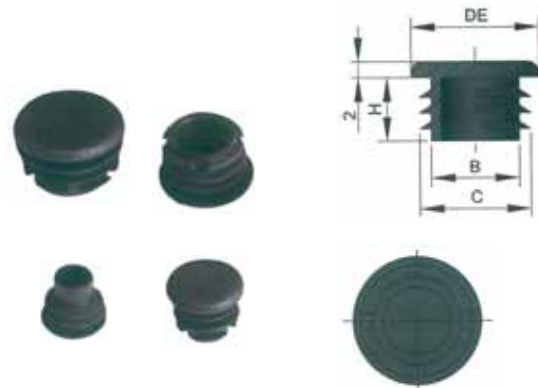

Wall- tube thickness	DE	H	B	C	Kg	COD.
1-1,5	10	8	5,5	8	0,01	7640149
1-1,5	12	8	7	10	0,01	7640152
1-1,5	14	8	9	1,5	0,01	7640154
1-1,5	16	8	11	14	0,01	7640146
1-1,5-2	18	9	12	15,5	0,01	7640147

Stainless steel.

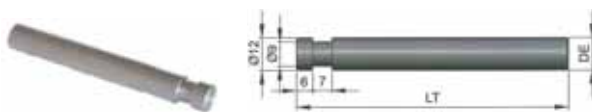

DE	LT	Kg	COD.
12	100	0,09	8220335
12	150	0,13	8220380
14	100	0,12	8220336
15	100	0,14	8220337
16	100	0,14	8220338

For clamps 8210038,  
8210039, 8210040,  
8210071,8210072,  
8210073, 8210112,  
8210155, 8210142,  
8210161, 8210317,  
8210184,



For clamps 8210014,  
8210015, 8210016,  
8210050, 8210051,  
8210052, 8210121,  
8210151, 8210138,  
8210157, 8210109,  
8210095.

DE	LT	Kg	COD.
10	8	0,04	8222780
10	8	0,07	8222790
12	10	0,09	8220339
14	12	0,12	8220340
15	12	0,14	8220341
16	14	0,16	8220342

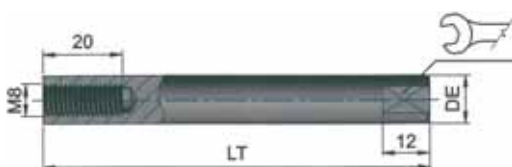

For clamps 8210038,  
8210212, 8210525,  
8210270,8210277

DE	LT	Kg	COD.
12	100	0,09	8220343
14	100	0,12	8220344
15	100	0,14	8220345
16	100	0,16	8220342

# Clamps for round profile guides

Reinforced polyamide.

**DOUBLE CLAMP**



DV	DE	L	Kg	COD.
12	-	-	0,11	8210212

Reinforced polyamide, pin, washer and nut in stainless steel.

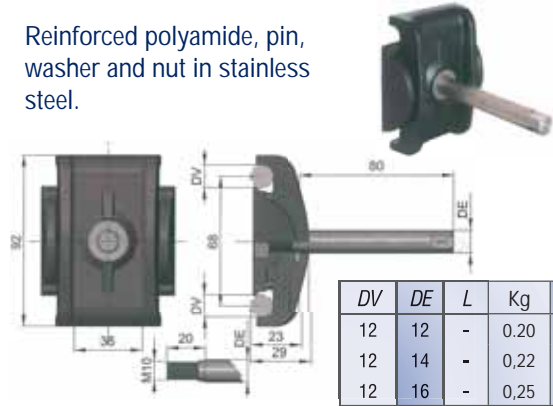

DV	DE	L	Kg	COD.
12	12	-	0,20	8240211
12	14	-	0,22	8240214
12	16	-	0,25	8240215

Reinforced polyamide, fastener in stainless steel.

**SINGLE CLAMP**

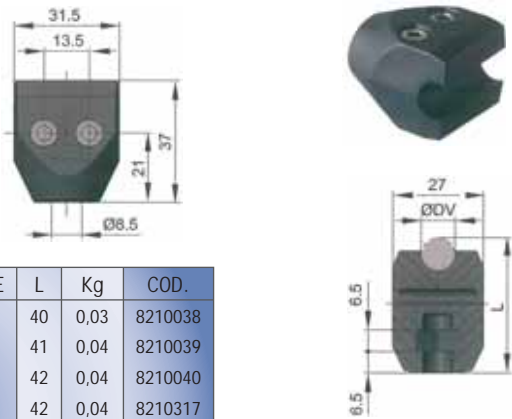

DV	DE	L	Kg	COD.
8	-	40	0,03	8210038
10	-	41	0,04	8210039
12	-	42	0,04	8210040
14	-	42	0,04	8210317

Reinforced polyamide, pin and fastener in stainless steel.

DV	DE	L	Kg	COD.
8	12	40	0,14	8240041
	14	40	0,17	8240042
	16	40	0,20	8240043
10	12	41	0,14	8240044
	14	41	0,17	8240045
	16	41	0,20	8240046
12	12	42	0,14	8240047
	14	42	0,17	8240048
	16	42	0,20	8240049
14	12	42	0,14	8240231
	14	42	0,17	8240232
	16	42	0,20	8240233



Reinforced polyamide, fastener in stainless steel.

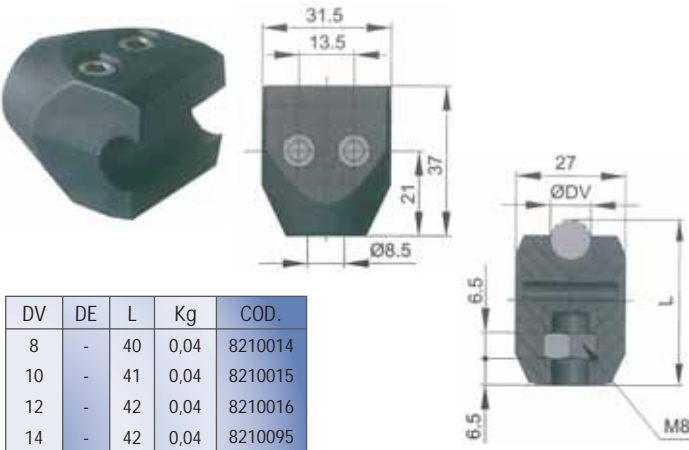

DV	DE	L	Kg	COD.
8	-	40	0,04	8210014
10	-	41	0,04	8210015
12	-	42	0,04	8210016
14	-	42	0,04	8210095

Reinforced polyamide, pin and fastener in stainless steel.

DV	DE	L	Kg	COD.
8	12	40	0,11	8240017
	14	40	0,14	8240018
	16	40	0,17	8240019
10	12	41	0,11	8240020
	14	41	0,14	8240021
	16	41	0,17	8240022
12	12	42	0,11	8240023
	14	42	0,14	8240024
	16	42	0,17	8240025
14	12	42	0,11	8240088
	14	42	0,14	8240089
	16	42	0,17	8240090

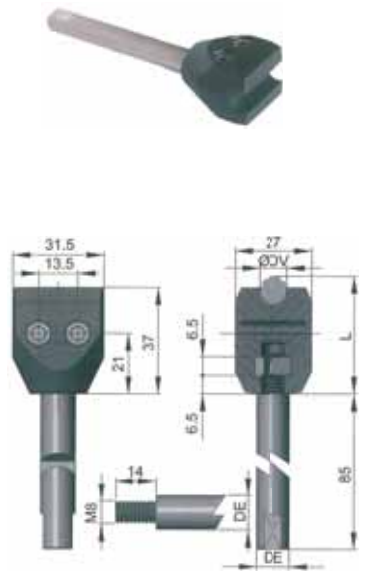

Clamps for round profile guides

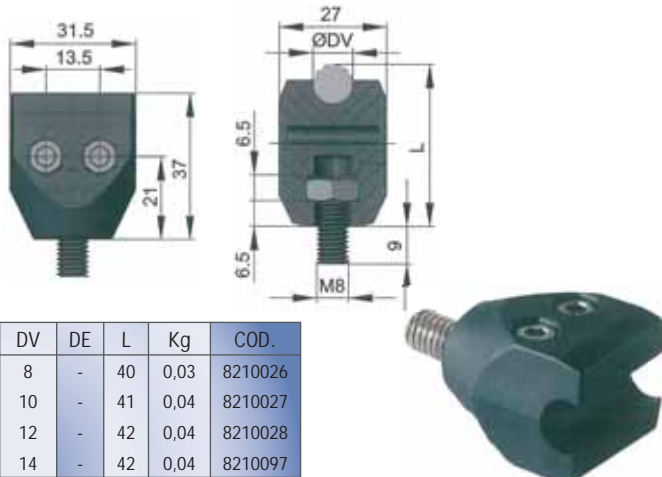

DV	DE	L	Kg	COD.
8	-	40	0,03	8210026
10	-	41	0,04	8210027
12	-	42	0,04	8210028
14	-	42	0,04	8210097

DV	DE	L	Kg	COD.
8	12	40	0,11	8240029
	14	40	0,14	8240030
	16	40	0,17	8240031
10	12	41	0,11	8240032
	14	41	0,14	8240033
	16	41	0,17	8240034
12	12	42	0,11	8240035
	14	42	0,14	8240036
	16	42	0,17	8240037
14	12	42	0,11	8240091
	14	42	0,14	8240092
	16	42	0,17	8240093

# Clamps for round profile guides

Reinforced polyamide, fastener in stainless steel.

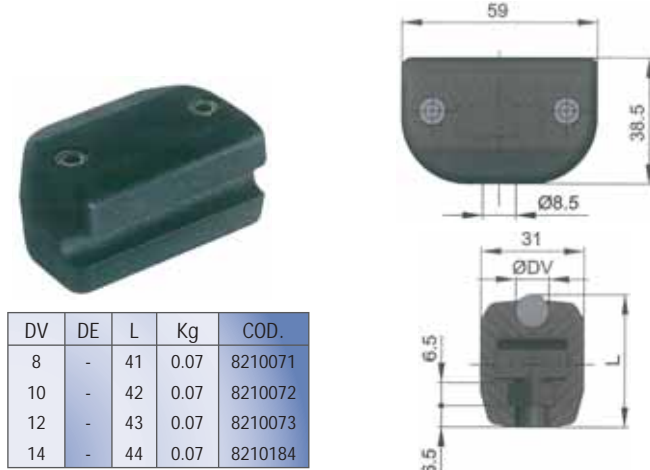

DV	DE	L	Kg	COD.
8	-	41	0.07	8210071
10	-	42	0.07	8210072
12	-	43	0.07	8210073
14	-	44	0.07	8210184

Reinforced polyamide, pin and fastener in stainless steel.

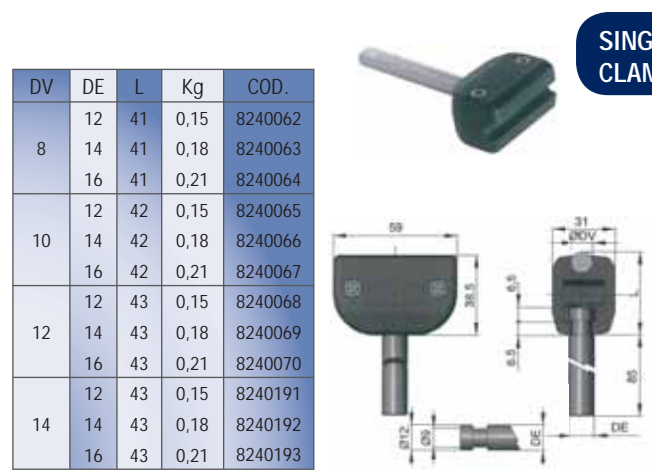

DV	DE	L	Kg	COD.
8	12	41	0,15	8240062
	14	41	0,18	8240063
	16	41	0,21	8240064
10	12	42	0,15	8240065
	14	42	0,18	8240066
	16	42	0,21	8240067
12	12	43	0,15	8240068
	14	43	0,18	8240069
	16	43	0,21	8240070
14	12	43	0,15	8240191
	14	43	0,18	8240192
	16	43	0,21	8240193

**SINGLE CLAMP**

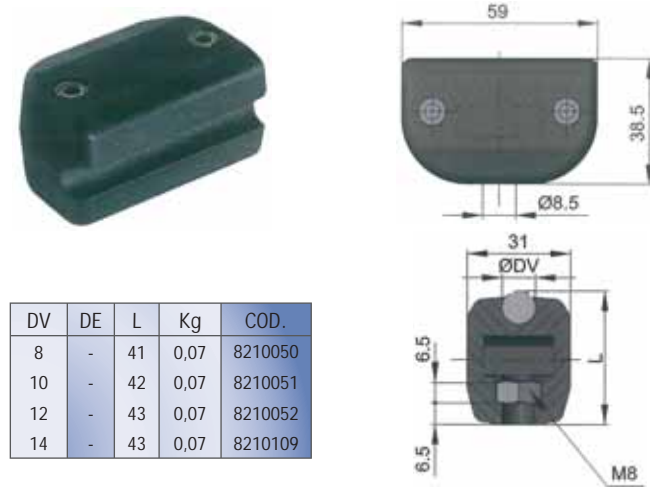

DV	DE	L	Kg	COD.
8	-	41	0,07	8210050
10	-	42	0,07	8210051
12	-	43	0,07	8210052
14	-	43	0,07	8210109

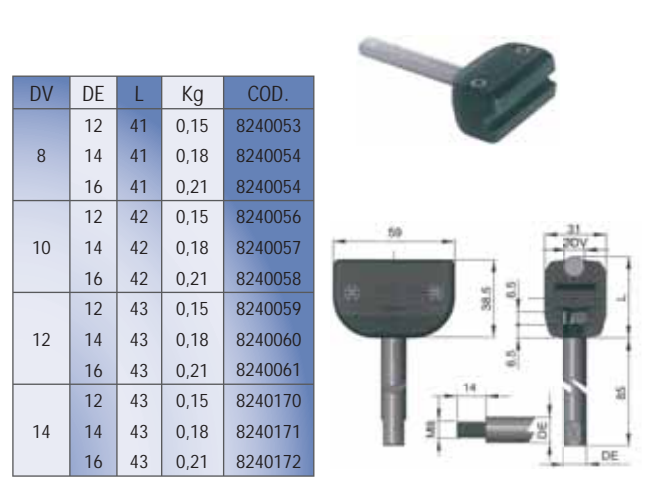

DV	DE	L	Kg	COD.
8	12	41	0,15	8240053
	14	41	0,18	8240054
	16	41	0,21	8240054
10	12	42	0,15	8240056
	14	42	0,18	8240057
	16	42	0,21	8240058
12	12	43	0,15	8240059
	14	43	0,18	8240060
	16	43	0,21	8240061
14	12	43	0,15	8240170
	14	43	0,18	8240171
	16	43	0,21	8240172

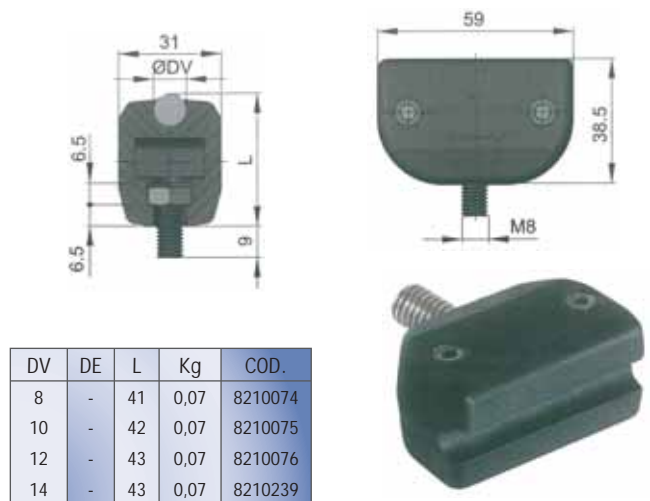

DV	DE	L	Kg	COD.
8	-	41	0,07	8210074
10	-	42	0,07	8210075
12	-	43	0,07	8210076
14	-	43	0,07	8210239

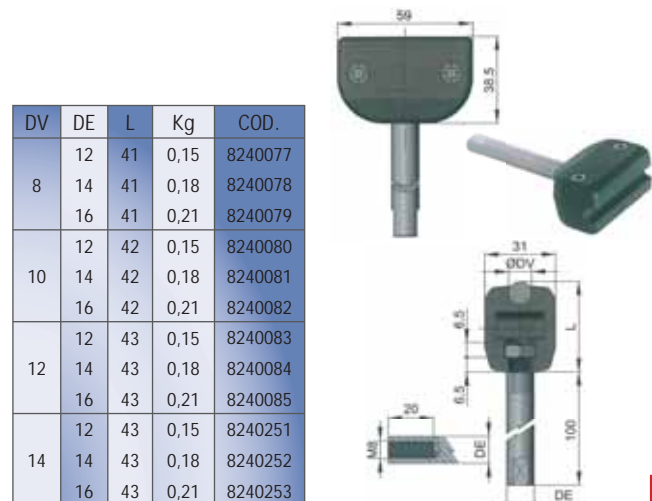

DV	DE	L	Kg	COD.
8	12	41	0,15	8240077
	14	41	0,18	8240078
	16	41	0,21	8240079
10	12	42	0,15	8240080
	14	42	0,18	8240081
	16	42	0,21	8240082
12	12	43	0,15	8240083
	14	43	0,18	8240084
	16	43	0,21	8240085
14	12	43	0,15	8240251
	14	43	0,18	8240252
	16	43	0,21	8240253

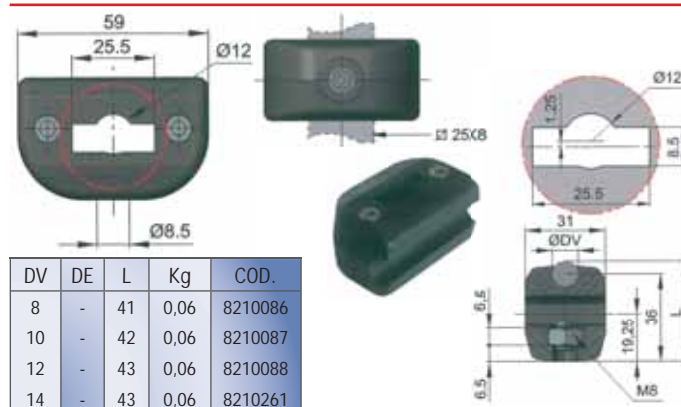

DV	DE	L	Kg	COD.
8	-	41	0,06	8210086
10	-	42	0,06	8210087
12	-	43	0,06	8210088
14	-	43	0,06	8210261

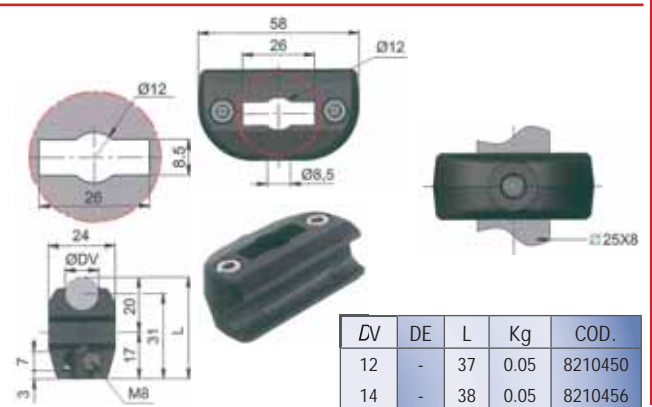

DV	DE	L	Kg	COD.
12	-	37	0,05	8210450
14	-	38	0,05	8210456

Clamps for round profile guides

# Clamps for "MC" guides

Reinforced polyamide.

**DOUBLE CLAMP**

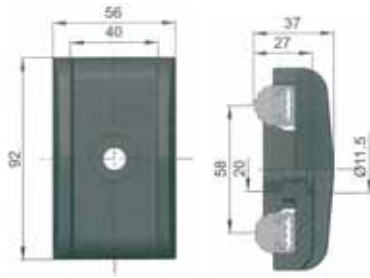

DE	Kg	COD.
-	0,10	8210525

Reinforced polyamide, pin, washer and nut in stainless steel.



DE	Kg	COD.
12	0,18	8240118
14	0,20	8240119
16	0,21	8240120

Reinforced polyamide, fastener in stainless steel.

**SINGLE CLAMP**

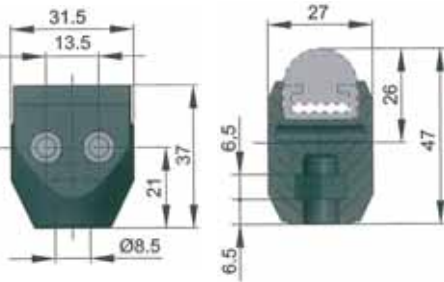
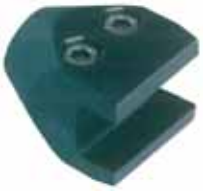

DE	Kg	COD.
-	0,03	8210112

Reinforced polyamide, pin and fastener in stainless steel.



DE	Kg	COD.
12	0,11	8240114
14	0,13	8240115
16	0,15	8240116

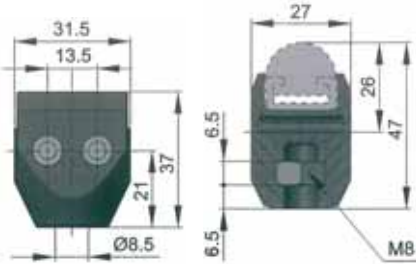
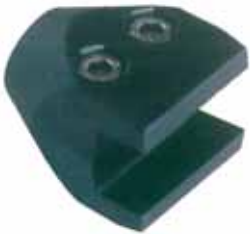

DE	Kg	COD.
-	0,03	8210121

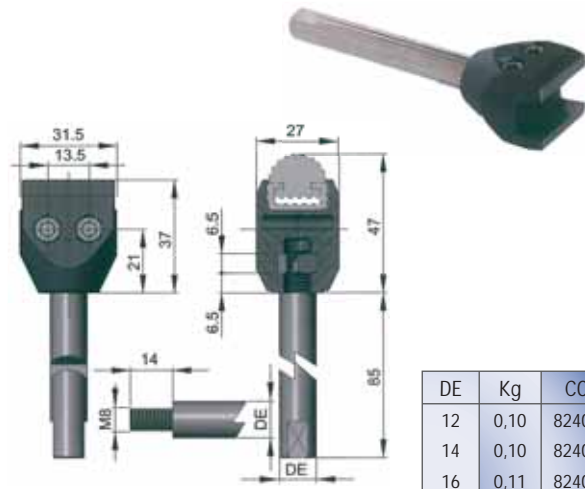

DE	Kg	COD.
12	0,10	8240122
14	0,10	8240123
16	0,11	8240124

Clamps for "MC" guides

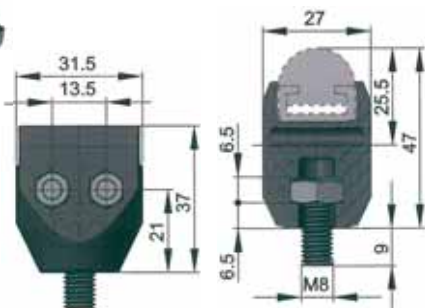

DE	Kg	COD.
-	0,03	8210125

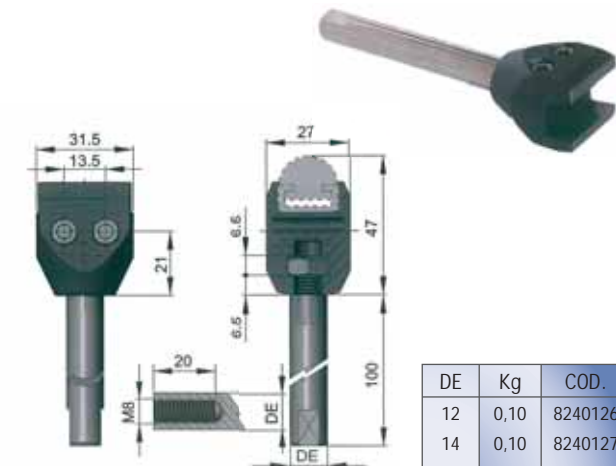

DE	Kg	COD.
12	0,10	8240126
14	0,10	8240127
16	0,11	8240128

# Clamps for "MC" guides

Reinforced polyamide, fastener in stainless steel.

DE	Kg	COD.
-	0,06	8210155



Reinforced polyamide, pin and fastener in stainless steel.

**SINGLE CLAMP FOR "MC" GUIDES**



DE	Kg	COD.
12	0,14	8240156
14	0,14	8240173
16	0,15	8240174

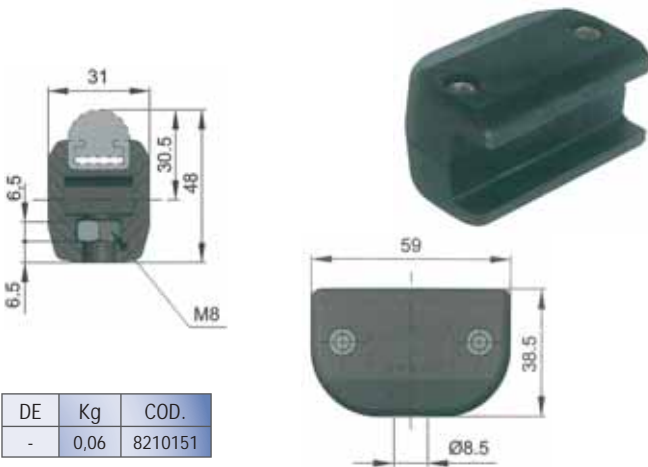

DE	Kg	COD.
-	0,06	8210151

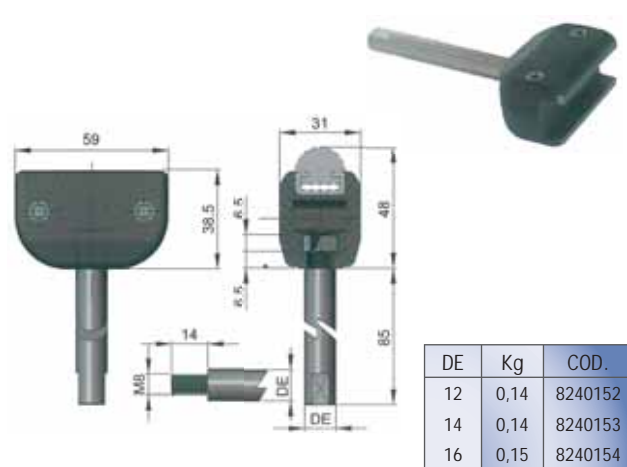

DE	Kg	COD.
12	0,14	8240152
14	0,14	8240153
16	0,15	8240154

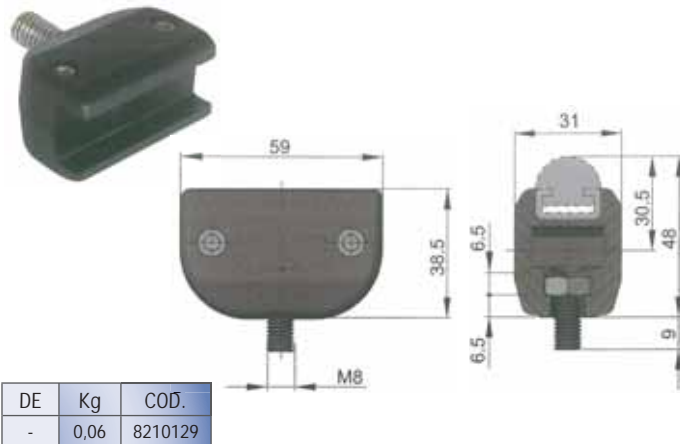

DE	Kg	COD.
-	0,06	8210129

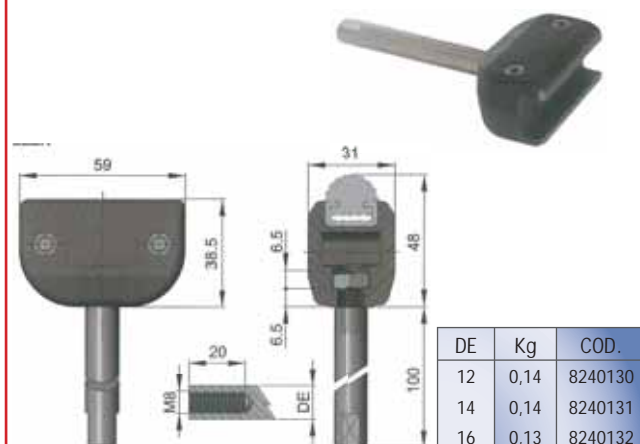

DE	Kg	COD.
12	0,14	8240130
14	0,14	8240131
16	0,13	8240132

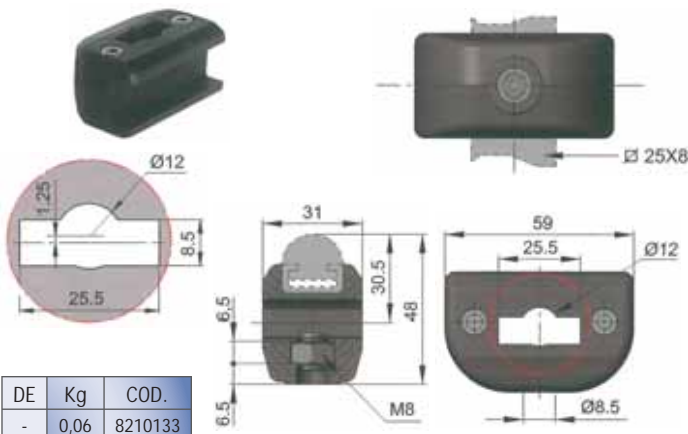

DE	Kg	COD.
-	0,06	8210133



Colour	Guide	L	Kg	COD.
Green	-	50	0,21	P20350
Black	-	50	0,21	P30350
Green	C2010SS	2	0,70	PSS20350L2
		3		PSS20350L3
Green	C2010	2	0,70	PZN20350L2
		3		PZN20350L2
Black	C2010SS	2	0,70	PSS30350L2
		3		PSS30350L3
Black	C2010	2	0,70	PZN30350L2
		3		PZN30350L3

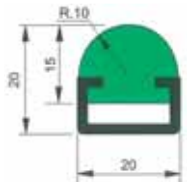

Clamps for "MC" guides

# Clamps for conical side guides

Reinforced polyamide.

**DOUBLE CLAMP**

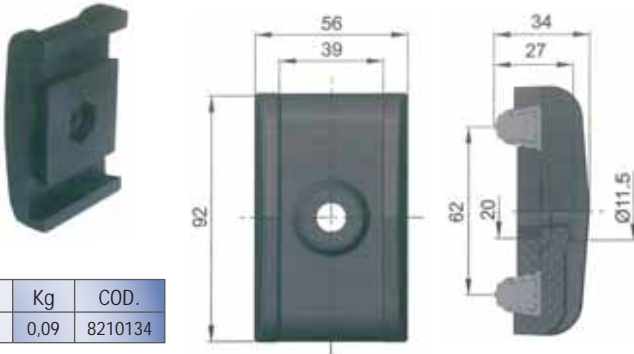

DE	Kg	COD.
-	0,09	8210134

Reinforced polyamide, pin, washer and nut in stainless steel.

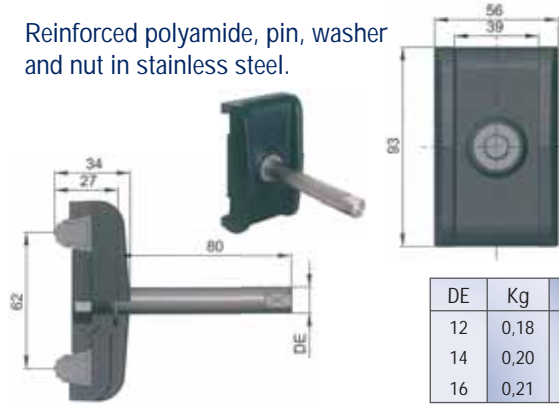

DE	Kg	COD.
12	0,18	8240135
14	0,20	8240136
16	0,21	8240137

Reinforced polyamide, fastener in stainless steel.

**SINGLE CLAMP**

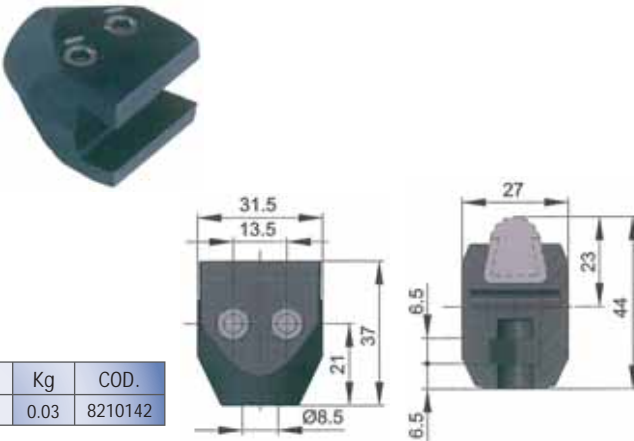

DE	Kg	COD.
-	0,03	8210142

Reinforced polyamide, pin and fastener in stainless steel.



DE	Kg	COD.
12	0,11	8240143
14	0,13	8240144
16	0,15	8240145

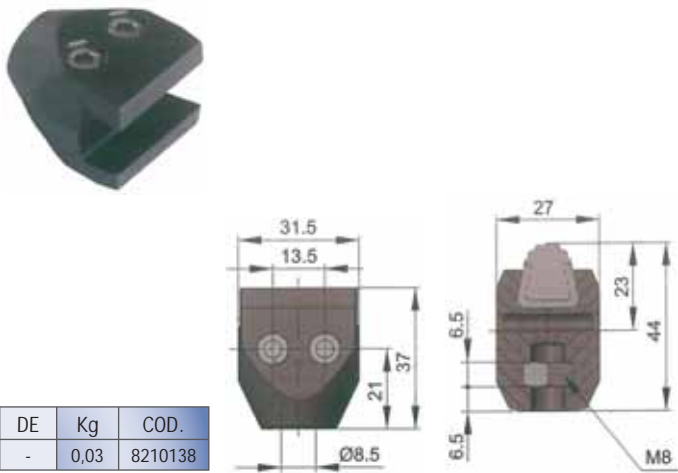

DE	Kg	COD.
-	0,03	8210138

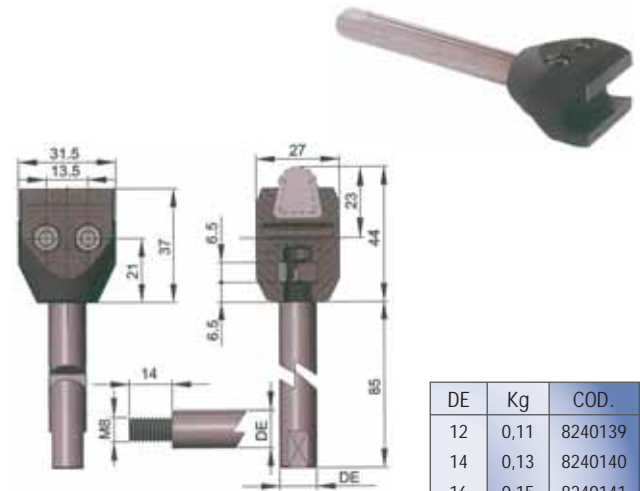

DE	Kg	COD.
12	0,11	8240139
14	0,13	8240140
16	0,15	8240141

Clamps for conical side guides

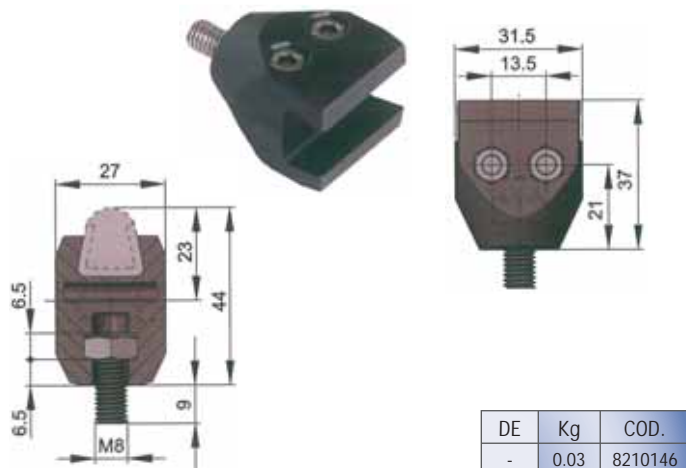

DE	Kg	COD.
-	0,03	8210146

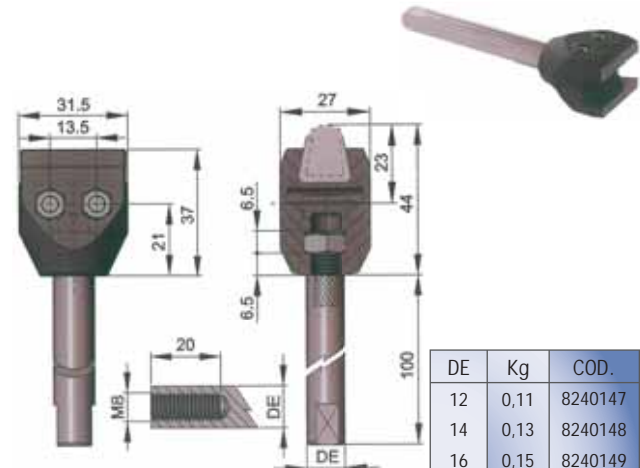

DE	Kg	COD.
12	0,11	8240147
14	0,13	8240148
16	0,15	8240149

# Clamps for conical side guides

Reinforced polyamide, fastener in stainless steel.

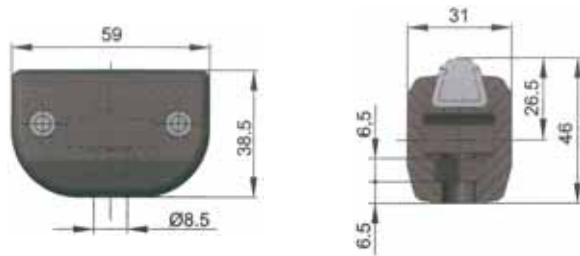

DE	Kg	COD.
-	0,06	8210161

Reinforced polyamide, pin and fastener in stainless steel.

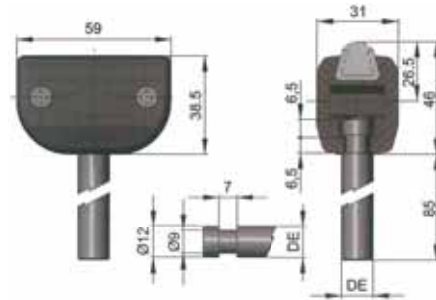

DE	Kg	COD.
12	0,14	8240162
14	0,16	8240163
16	0,18	8240164

DE	Kg	COD.
-	0,06	8210157

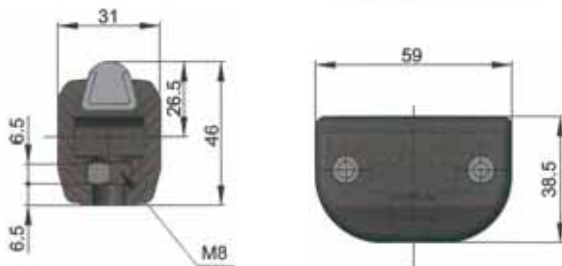

DE	Kg	COD.
12	0,14	8240158
14	0,16	8240159
16	0,18	8240160

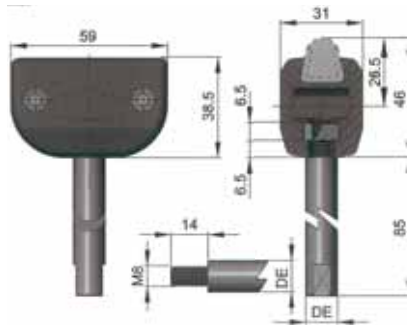

DE	Kg	COD.
-	0,06	8210165

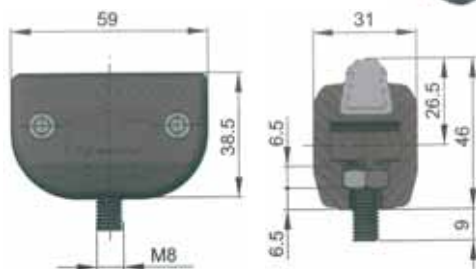

DE	Kg	COD.
12	0,14	8240166
14	0,16	8240167
16	0,18	8240168

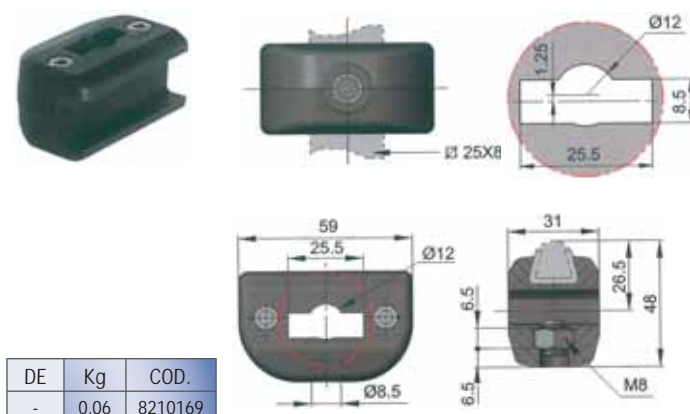
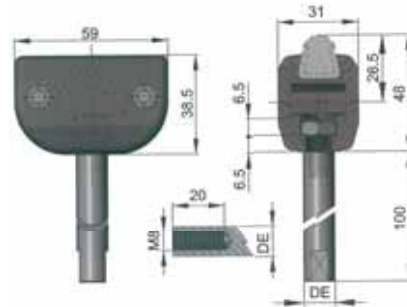

DE	Kg	COD.
-	0,06	8210169

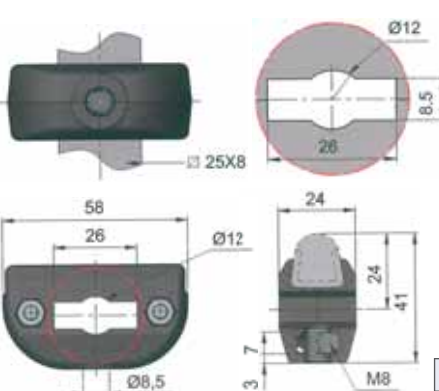

DE	Kg	COD.
-	0,05	8210461

## Clamps for conical side guides

Stainless steel.

GUIDE JOINT

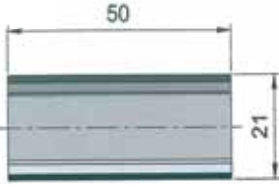

Kg	COD.
0,03	8214620

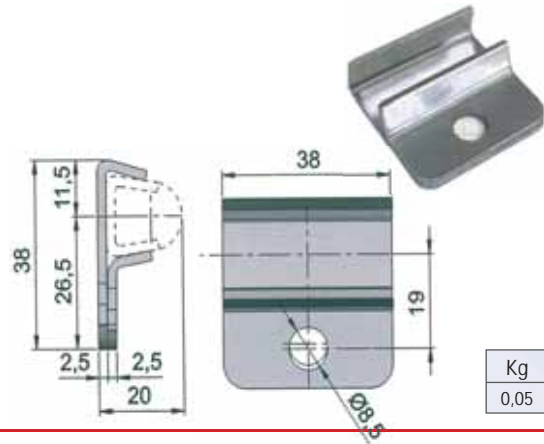
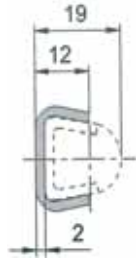

Kg	COD.
0,05	8214680

DOUBLE CLAMP

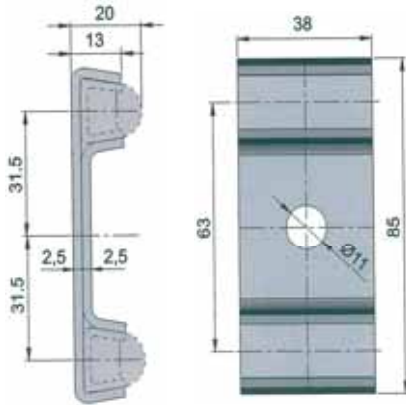

Kg	COD.
0.13	8214691

Reinforced polyamide.

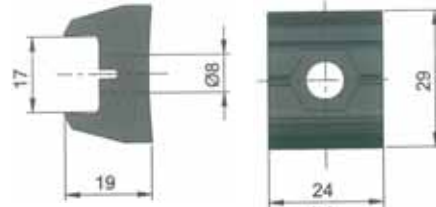

Kg	COD.
0.01	8210367

UHMW 1000 "DESLIDUR" Polyethylene.

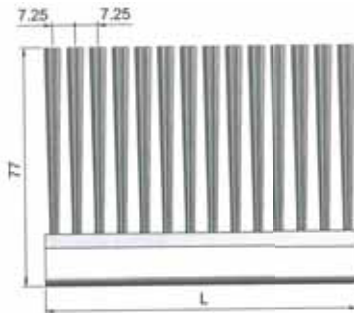
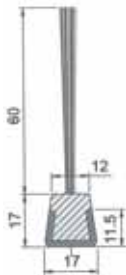

Colour	Guide	L	Kg	COD.
White	SS	500	0,72	CSS1010X05

## Extra side guides

Self-lubricating polyethylene.

Clamps for conical side guides/  
Extra side guides

L	Kg	COD.
3	1,0	P30447.15
6	2,0	P30447.20

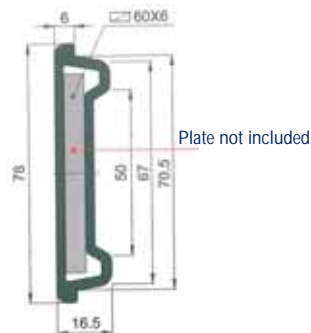

- Coefficient of linear expansion:  $2.5 \cdot 10^{-4} \text{ } ^\circ\text{C}^{-1}$
- working temperature:  $-35^\circ\text{C} - +70^\circ\text{C}$
- Minimum bending radius: 200 mm.

Reinforced polyamide, pin and fastener in stainless steel.

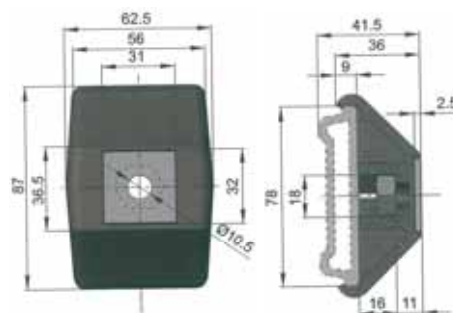

Kg	COD.



EXTRA  
SIDE  
GUIDES

Reinforced polyamide, pin and washer in stainless steel, nut in nickel plated brass.

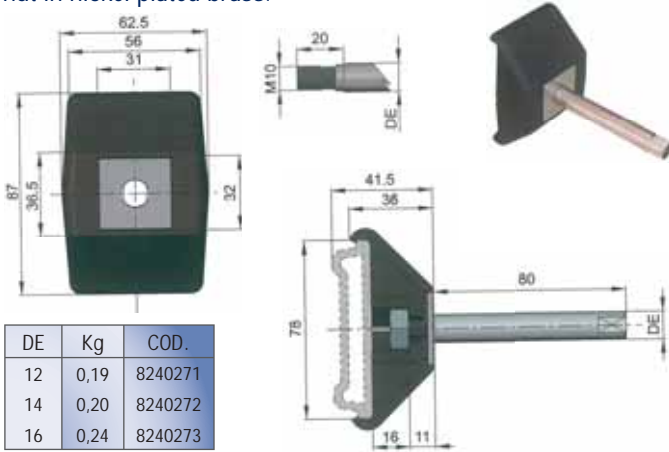

DE	Kg	COD.
12	0,19	8240271
14	0,20	8240272
16	0,24	8240273

Self-lubricating polyethylene

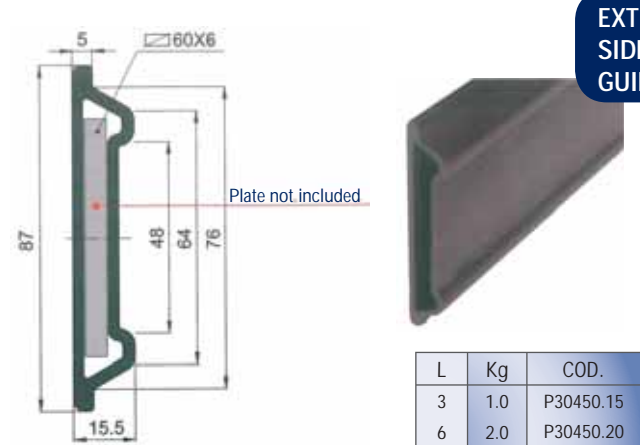

L	Kg	COD.
3	1.0	P30450.15
6	2.0	P30450.20

Reinforced polyamide, fastener in stainless steel.

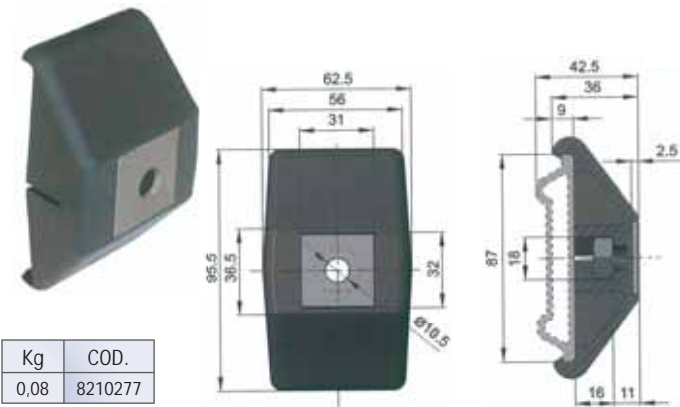

Kg	COD.
0,08	8210277

Reinforced polyamide, pin and washer in stainless steel, nut in nickel plated brass.

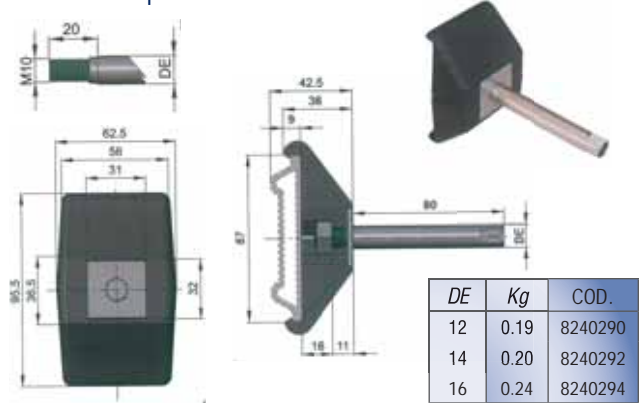

DE	Kg	COD.
12	0.19	8240290
14	0.20	8240292
16	0.24	8240294

Reinforced polyamide.

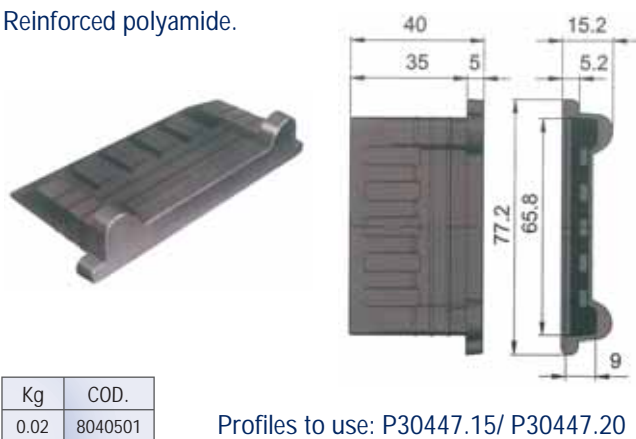

Kg	COD.
0.02	8040501

Profiles to use: P30447.15/ P30447.20

Reinforced polyamide.

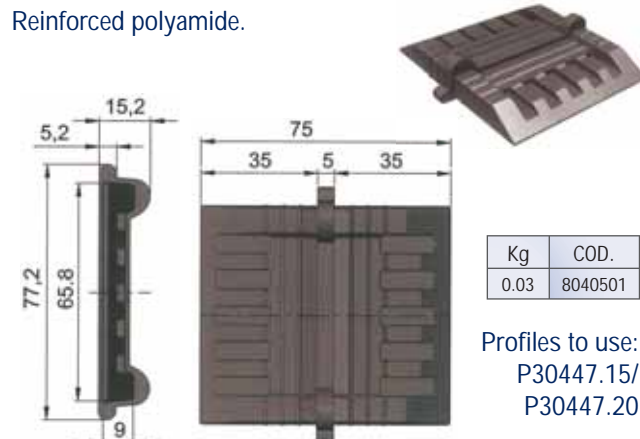

Kg	COD.
0.03	8040501

Profiles to use:  
P30447.15/  
P30447.20



Kg	COD.
0.02	8040560

Profiles to use: P30450.15/ P30450.20

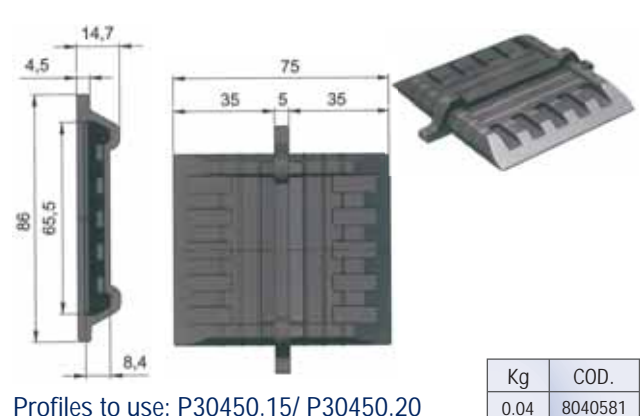

Kg	COD.
0.04	8040581

Profiles to use: P30450.15/ P30450.20

# Guides

Stainless steel.

GUIDE

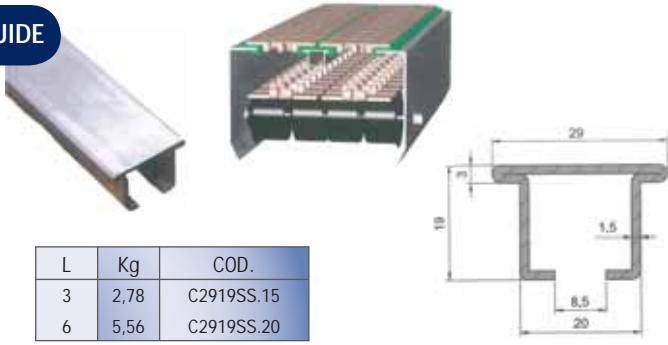

L	Kg	COD.
3	2,78	C2919SS.15
6	5,56	C2919SS.20

UHMW 1000 "DESLIDUR" Polyethylene.



Colour	Guide	L	Kg	COD.
Green	-	3	0,64	P20376.15
Green	-	6	1,28	P20376.20
Green	C2919SS.15	3	3,42	PSS20376.15
Green	C2919SS.20	6	6,84	PSS20376.20

UHMW 1000 "DESLIDUR" Polyethylene.

Colour	Guide	L	Kg	COD.
Green	-	3	0,67	P20378.15
Green	-	6	1,34	P20378.20
Green	C2919SS.15	3	3,45	PSS20378.15
Green	C2919SS.20	6	6,90	PSS20378.20

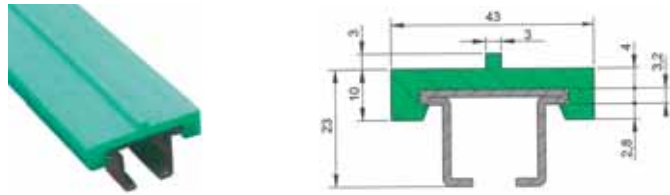

# Accessories

Reinforced polyamide.

CONNECTING ELEMENT

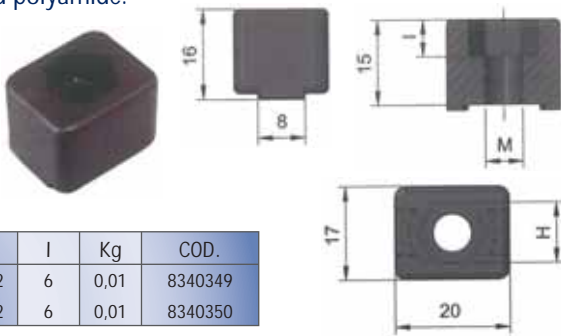

H	M	I	Kg	COD.
10	Ø6,2	6	0,01	8340349
13	Ø8,2	6	0,01	8340350

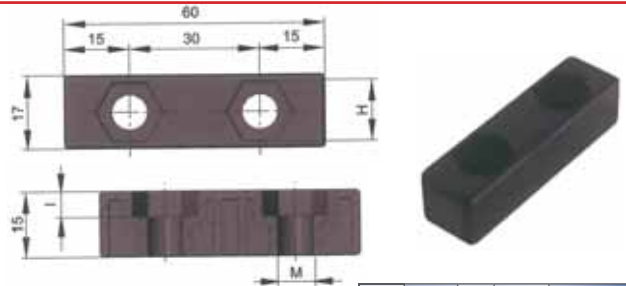

H	M	I	Kg	COD.
10	Ø6,2	6	0,02	8340359
13	Ø8,2	6	0,02	8340360

SLIDING SHOE

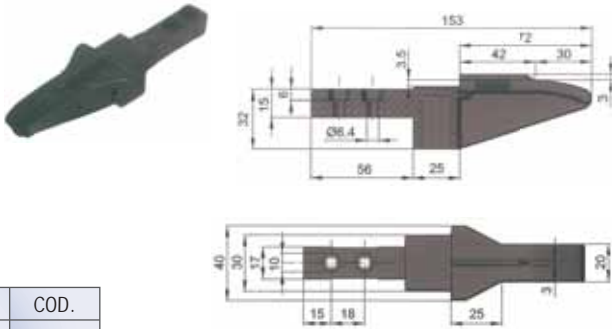

Kg	COD.
0.04	8340385

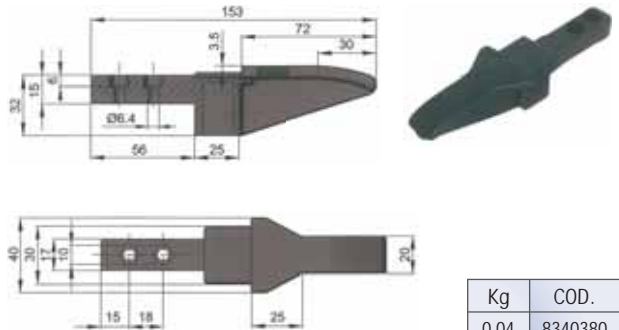

Kg	COD.
0.04	8340380

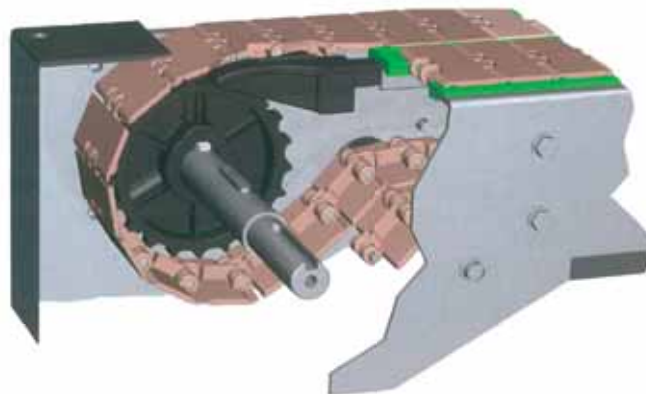

# Drip tray supports

Reinforced polyamide - Stainless steel.

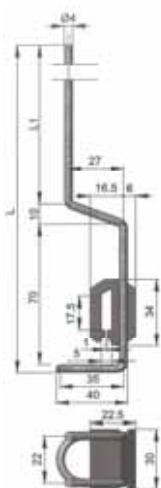
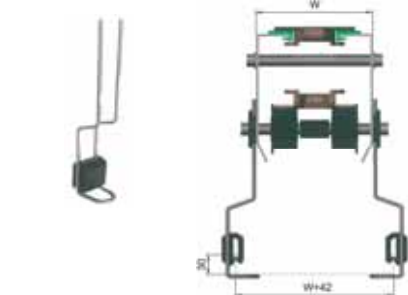

L mm.	L1 mm.	Kg	COD.
180	100	0,08	8225311
250	170	0,10	8225312
280	200	0,12	8225314

L mm.	L1 mm.	Kg	COD.
250	-	0,08	8226218
400	-	0,10	8226219

DRIP TRAY SUPPORTS

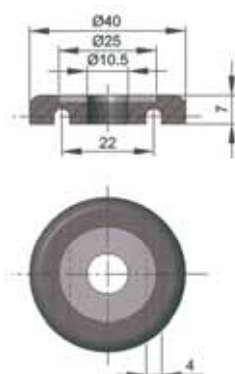

Kg	COD.
0,02	8225207

FIXING WASHER

# Cross block and photocell accessories

Reinforced polyamide.

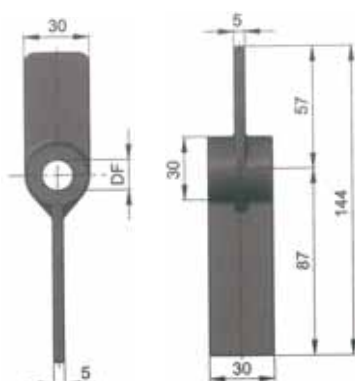

DF	Kg	COD.
14	0,05	8330237

Reinforced polyamide, fastener in stainless steel.

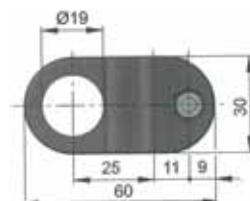

ØDF	ØDC	Kg	COD.
10	8	0,02	8330221
12	10	0,02	8330222
14	12	0,02	8330223

ØDF	ØDC	Kg	COD.
10	8	0,03	8330227
12	10	0,03	8330228
14	12	0,03	8330229

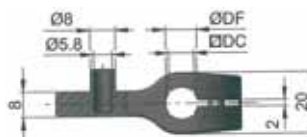
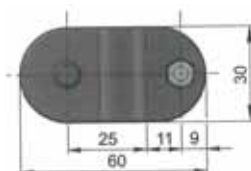

Drip tray supports/ Cross block and photocell accessories

Reinforced polyamide

DF	Kg	COD.
12	0,1	8330301
14	0,1	8330303
15	0,1	8330305
16	0,1	8330306
18	0,1	8330308
20	0,1	8330310

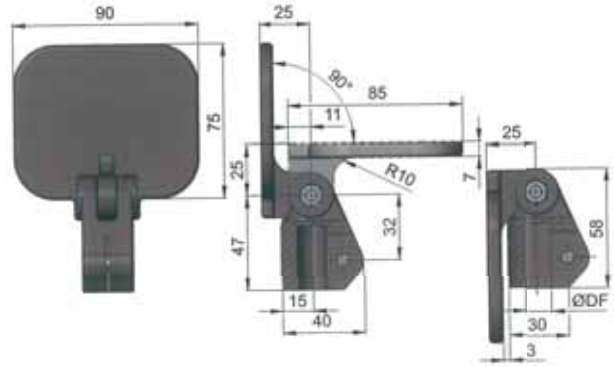

Reinforced polyamide, fastener in stainless steel.

CROSS BLOCK

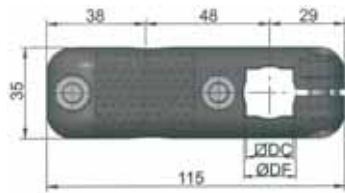

ØDF	ØDC	Kg	COD.
18	15	0.20	8330648
20	18	0.19	8330650

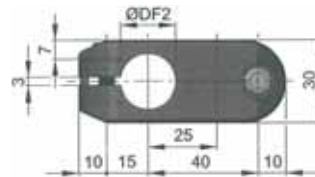
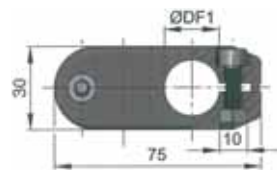

ØDF	ØDC	Kg	COD.
14	14	0.07	8330194
14	15	0.07	8330195
14	16	0.07	8330196
15	15	0.07	8330197
15	16	0.07	8330198
16	16	0.07	8330199
18	18	0.07	8330201
20	20	0.07	8330202

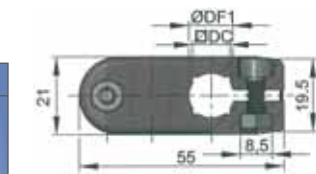
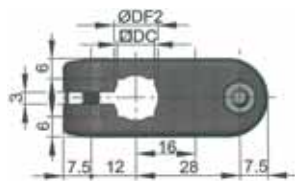

ØDF1	ØDF2	ØDC	Kg	COD.
10	10	8	0,03	8330187
12	12	10	0,03	8330189
14	14	12	0,03	8330191

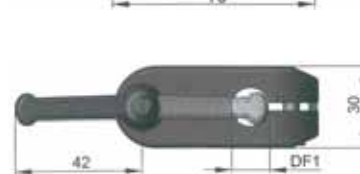
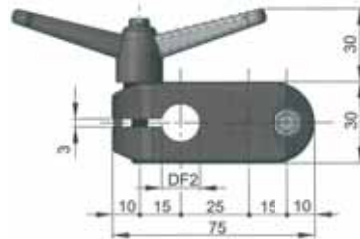

ØDF	ØDC	Kg	COD.
14	14	0,09	8330740
15	15	0,09	8330745
16	16	0,09	8330746
18	18	0,09	8330748
20	20	0,09	8330750

Reinforced polyamide, fastener in stainless steel.



Detail x

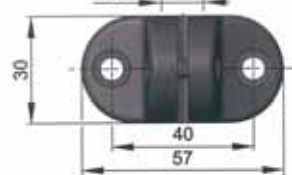
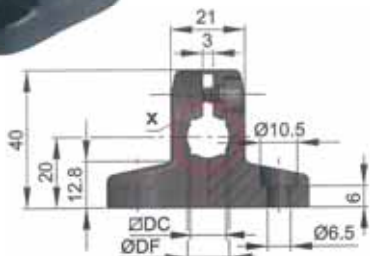

ØDF	ØDC	Kg	COD.
10	8	0,03	8330215
12	10	0,03	8330216
14	12	0,03	8330217

Reinforced polyamide.

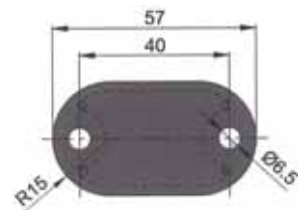

For cross block:  
8330215, 8330216,  
8330217

H	Kg	COD.
4	0.01	8330890
6	0.02	8330895

# Cross block and photocell accessories

Reinforced polyamide, fastener in stainless steel.

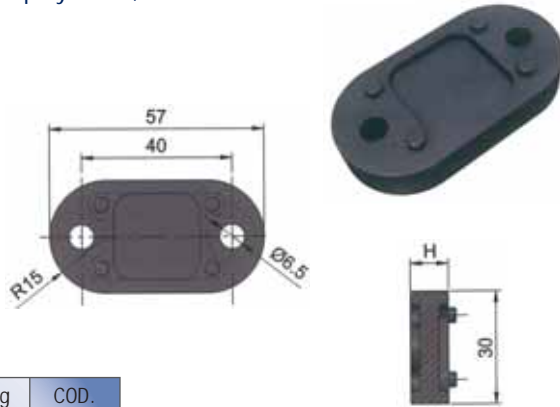

H	Kg	COD.
8	0,02	8330896
10	0,02	8330897
12	0,02	8330899

For cross block:  
8330215, 8330216,  
8330217

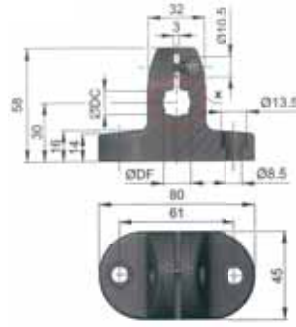

**CROSS  
BLOCK**



ØDF	DC	Kg	COD.
14	12	0,09	8330270
16	14	0,09	8330271
18	16	0,09	8330273
20	18	0,09	8330275

Reinforced polyamide.

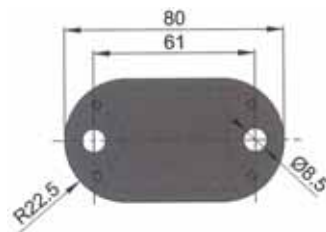

H	Kg	COD.
10	0,03	8330901

For cross block:  
8330270, 8330271,  
8330273, 8330275



**CROSS  
BLOCK  
SPACER**

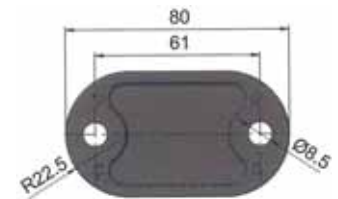

H	Kg	COD.
20	0,06	8330905

For cross block:  
8330270, 8330271,  
8330273, 8330275

## Frame system

Reinforced polyamide.

For tube: Ø25x25x1,5 mm.



TIPO TYPE	Kg	COD.
A	0,05	7640001



TIPO TYPE	Kg	COD.
B	0,07	7640002



TIPO TYPE	Kg	COD.
C	0,09	7640003



TIPO TYPE	Kg	COD.
D	0,07	7640004



TIPO TYPE	Kg	COD.
E	0,09	7640005



TIPO TYPE	Kg	COD.
F	0,11	7640006



TIPO TYPE	Kg	COD.
G	0,13	7640007



TIPO TYPE	Kg	COD.
H	0,05	7640008

Cross block and photocell accessories/  
Frame system

Reinforced polyamide, fastener in stainless steel.

**CONNECTING GUIDE**

TIPO TYPE	Kg	COD.
AT	0,12	7645101

For tube: Ø25x25x1,5 mm.

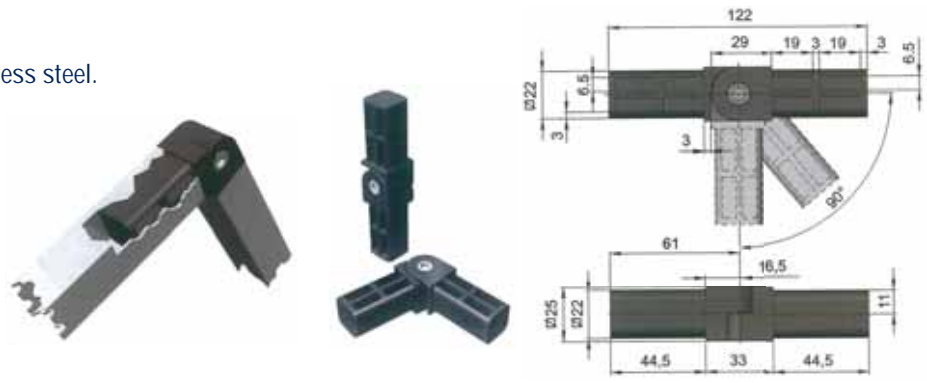

Stainless steel.

**STRUCTURAL FIXATION SUPPORT**

L	Kg	COD.
50mm.	0,09	7640405
100mm.	0,15	7640410
150mm.	0,20	7640415

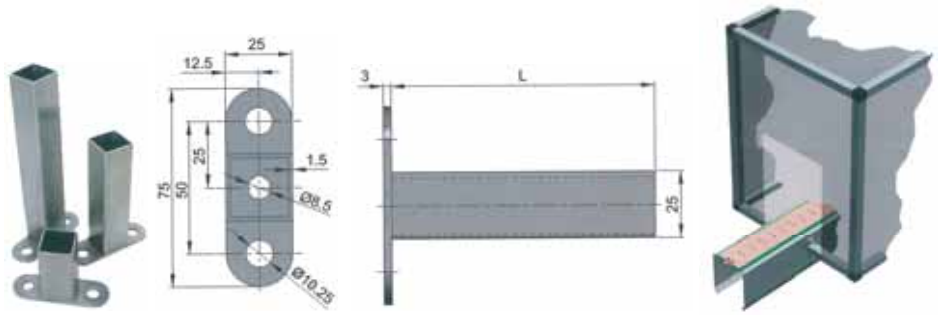

Anodized aluminium - stainless steel.

**25X25X1.5 STRUCTURE OR PAVEMENT TUBE**

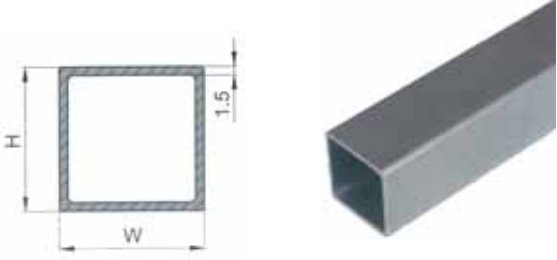

MAT.	H	W	L	Kg	COD.
AA	25	25	3	1,09	7641215
			6	2,18	7641220
SS	25	25	3	3,21	7641515
			6	6,42	7641520

Polyethylene black colour.

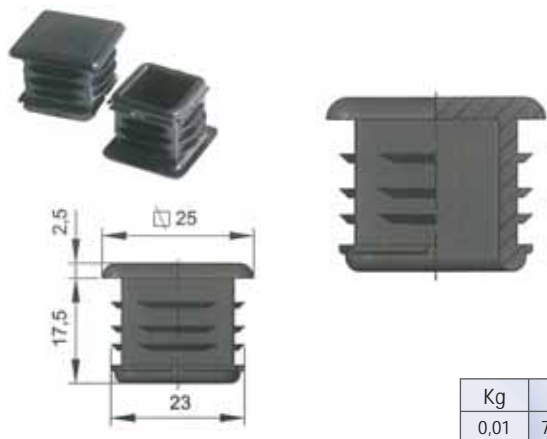

Kg	COD.
0,01	7640110

Polyethylene black colour.

**RUNNER PROFILES**

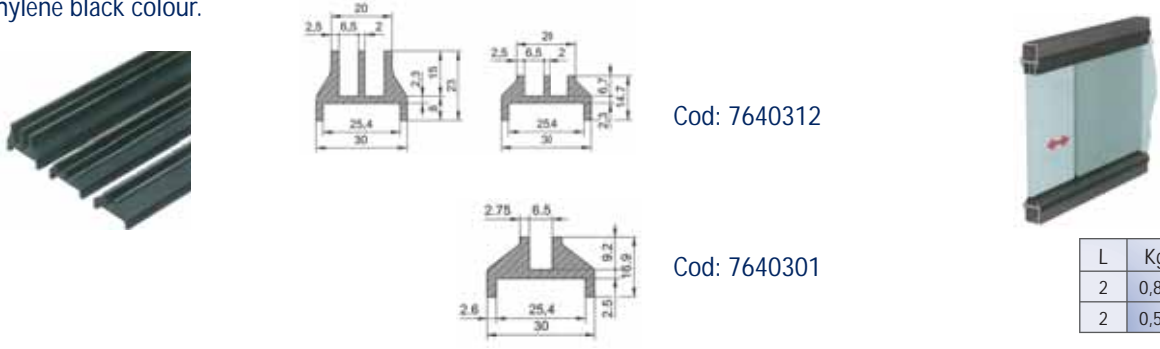

Cod: 7640312

Cod: 7640301

L	Kg	COD.
2	0,85	7640312
2	0,53	7640301

Rigid - Flexible PVC.

**PROFILE FOR SMOOTH TUBE**



1. PVC flexible area
2. Panel
3. Upper profil
4. Down profil
5. Smooth tube

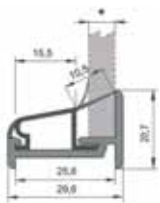

★	L	Kg	COD.
5<★>8	3	0,27	7640315

# Frame accessories

Magnetic door stop.  
Reinforced polyamide + regulable magnet.

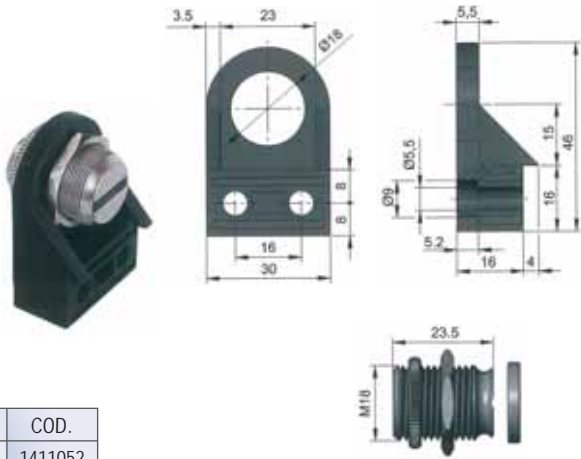

Kg	COD.
0,06	1411052

Reinforced polyamide.

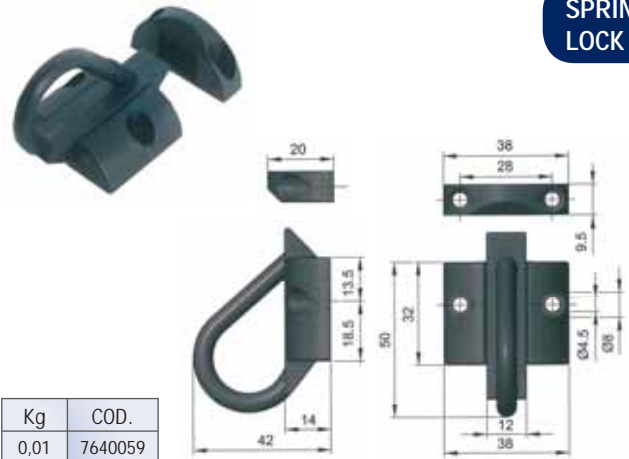

**SPRING LOCK**

Kg	COD.
0,01	7640059

Panel locking attachment.  
Reinforced polyamide.

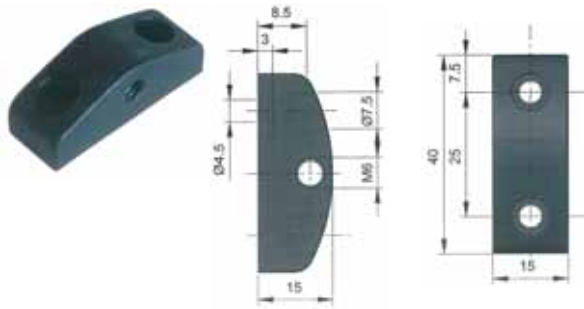

Kg	COD.
0,01	7640060

Reinforced polyamide, fastener in stainless steel.

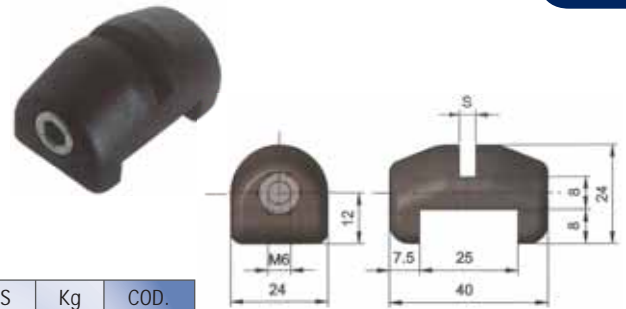

**PANEL CLAMP**

S	Kg	COD.
4	0,03	7640051
5	0,03	7640052
6	0,03	7640053

Reinforced polyamide.

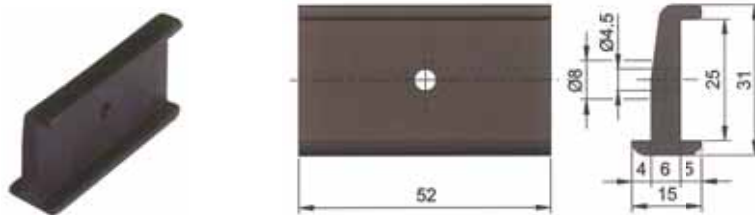

**STOP FOR HINGED DOORS**

Kg	COD.
0,01	7640501

# Handles

Reinforced polyamide.

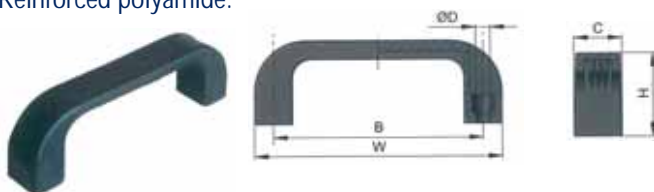

B	W	C	ØD	H	F	Kg	COD.
94	110	21	Ø6,5	37	-	0,04	7809010
116	133	24	Ø9	40	-	0,06	7809011
120	139	24	Ø8,5	40	-	0,08	7809012
117	140	24	Ø8,5	40	-	0,08	7809013
132	149	24	Ø9	40	-	0,09	7809014

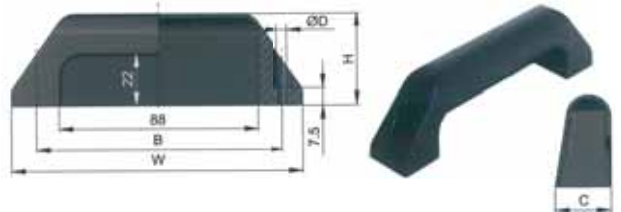

B	W	C	ØD	H	M	Kg	COD.
112	130	24	Ø6,3	41	-	0,06	7809410

Frame accessories/  
Handles

# Handles

Reinforced polyamide, bush in zinc.



B	W	C	ØD	H	M	Kg	COD.
140	170	25	-	57	M8	0,17	7809210

Reinforced polyamide.

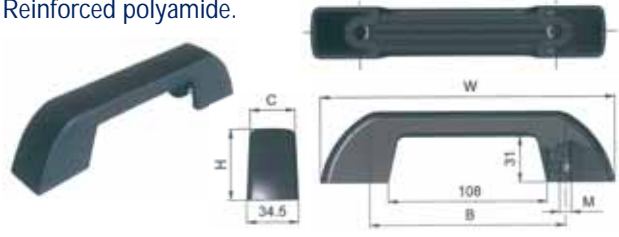

B	W	C	ØD	H	M	Kg	COD.
133	200	30	-	48	M8	0,11	7809310

# Hinges

Reinforced polyamide, pin in zinc plated steel.

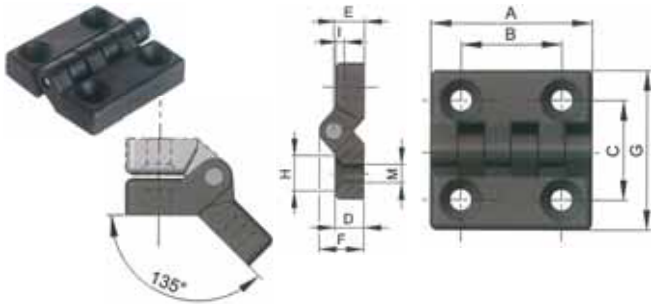

A	B	C	D	E	F	G	H	I	M	Kg	COD.
48	30	30	10	10	15	48	Ø13,5	3	Ø6,5	0,03	7810129
64	40	40	13	13	19	64	Ø13,5	3	Ø6,5	0,06	7810130
96	60	63	16	17	24	96	Ø16	4,6	Ø8	0,15	7810131

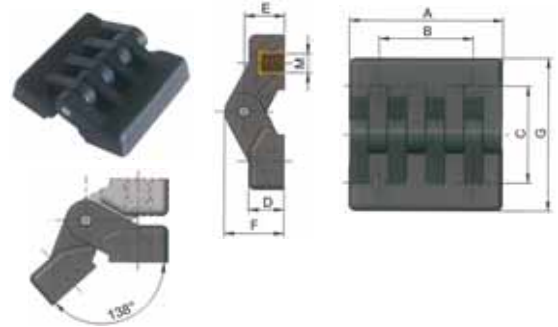

A	B	C	D	E	F	G	H	I	M	Kg	COD.
49	30	32	11	13	19	49	-	-	M5	0,06	7640208
49	30	32	11	13	19	49	-	-	M6	0,06	7640209

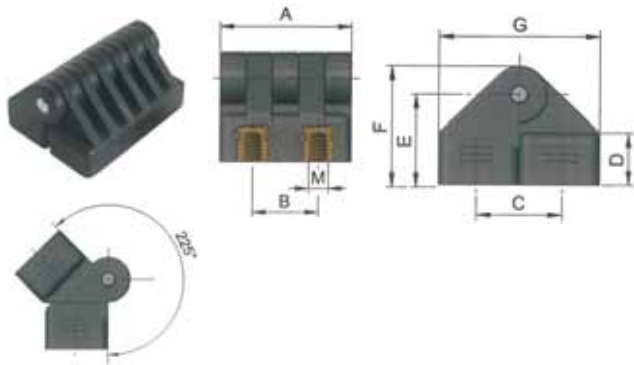

A	B	C	D	E	F	G	H	I	M	Kg	COD.
30	15	18	11	19	25	36	-	-	M5	0,04	7810110
54	30	21	13	22	29	42	-	-	M6	0,05	7810111
78	42	31	16	29	40	62	-	-	M8	0,06	7810112

Reinforced polyamide, pin in stainless steel.

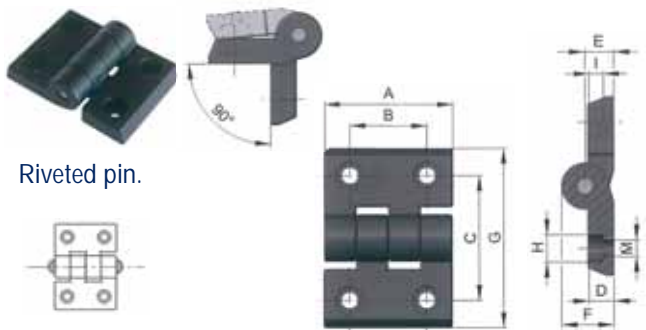

Riveted pin.

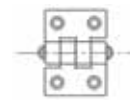

★ Reinforced

A	B	C	D	E	F	G	H	I	M	Kg	COD.
50	30	46	10	11	20	70	Ø10,5	6	Ø6,5	0,04	7810210
50*	30	46	10	11	20	70	Ø10,5	6	Ø6,5	0,04	7810211
50	30	46	10	11	20	70	Ø13,5	6	Ø8,5	0,04	7810212



A	B	C	D	E	F	G	H	I	M	Kg	COD.
102	72,5	49,5	11,5	10,5	19	80	Ø10,5	6	Ø6,5	0,10	7810220
102	72,5	49,5	11,5	10,5	19	80	Ø13,5	8	Ø8,5	0,10	7810221

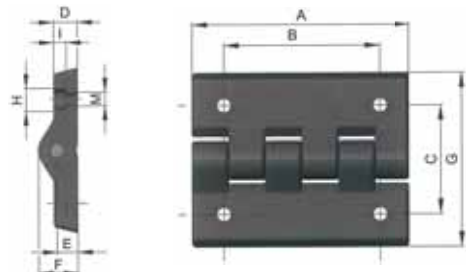



Head and fastener in stainless steel, tub in metrakilate.



Liters	L	Kg	COD.
1'5	275	0,90	8417387
2'5	375	1,00	8417389
3'5	475	1,20	8417392

Greaser regulation by air intake-reduction.

## Guides for bottling and packaging

UHMW 1000 "DESLIDUR" Polyethylene.

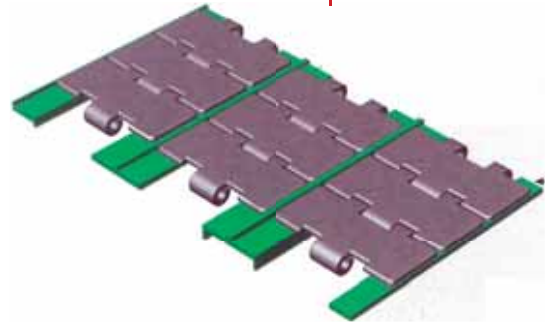

Standard Length

COLOUR	H	W									
		15	20	25	30	35	40	45	50	60	70
Green	3	P20100	P20101	P20102	P20103	P20104	P20105	P20106	P20107	P20109	P20111
Black	3	P30100	P30101	P30102	P30103	P30104	P30105	P30106	P30107	-	-
Kg/m	-	0,05	0,06	0,07	0,09	0,10	0,11	0,13	0,14	0,17	0,20
Green	5	P20120	P20121	P20122	P20123	P20124	P20125	P20126	P20127	-	-
Black	5	P30120	P30121	P30122	P30123	P30124	P30125	P30126	P30127	-	-
Kg/m	-	0,07	0,10	0,12	0,14	0,17	0,19	0,21	0,24	-	-



COLOUR	W	H	C	I	A	h	L	Kg/m	COD.
Green	20	10,5	14,5	3	-	-	50	0,11	P20269
Green	25	10,5	20	3	-	-	50	0,12	P20274
Black									P30274

COLOUR	W	H	C	I	A	h	L	Kg/m	COD.
Green	20	9	13	3	2,5	2,5	50	0,12	P20275
Black									P30275
Green	25	9	13	3	2,5	2,5	50	0,17	P20271
Black									P30271

COLOUR	W	H	C	I	A	h	L	Kg/m	COD.
Green	40	10,3	20	3	-	-	50	0,16	P20282
Black									P30282

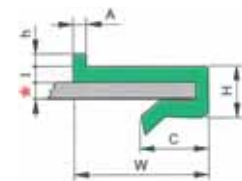
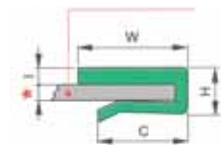

Wear strip to be used with plate width of 1.5 to 3 mm.

UHMW 1000 "DESLIDUR"  
Polyethylene.

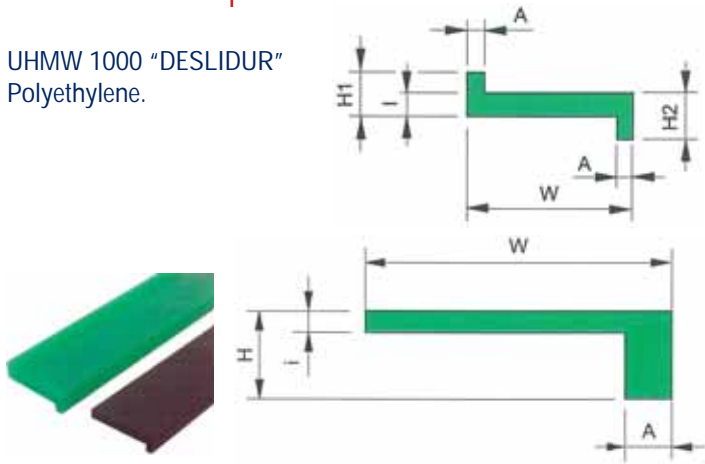

COLOUR	C	W	H	i	A	L	Kg/m	COD.
Green	L	20	5,5	3	2	50	0,06	P20254
Black								P30254
Green	L/53	53	6	3	2	50	0,16	P20255
Black								P30255
Green	L/23	23	7	4	4,8	50	0,11	P20256
Green	L/41	41	12	3	6	2	0,17	P20257L2
Black	L/20	10	5,5	3	2,5	50	0,07	P20258

COLOUR	C	W	H1	H2	I	A	L	Kg/m	COD.
Green	Z	20	5,5	5,5	3	2	50	0,07	P20250
Black									P30250
Green	Z/23	23	9	7	4	3	50	0,12	P20253
Black									P30253

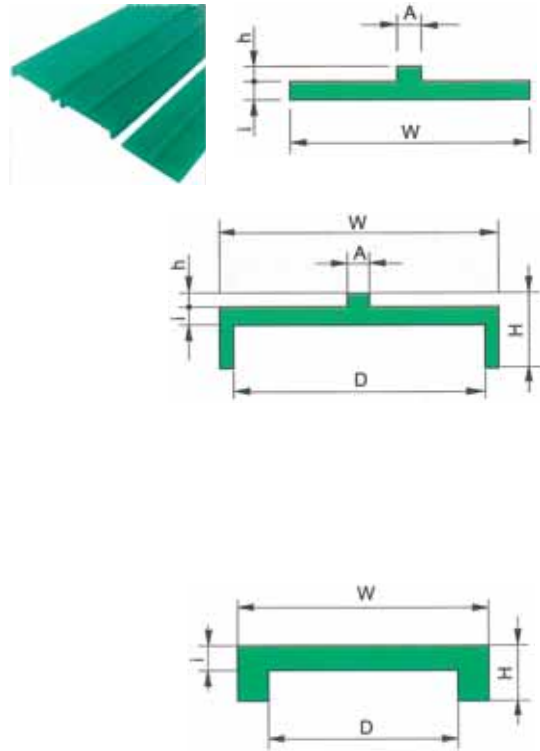

COLOUR	C	W	h	i	D	H	A	L	Kg/m	COD.
Green	T	40	2,5	3	-	-	4	50	0,11	P20260
Black										P30260

COLOUR	C	W	h	i	D	H	A	L	Kg/m	COD.
Green	DZ/36	40	3	3	36	9	4	50	0,13	P20262
Black										P30262
Green	DZ/32	44	2,5	3	32	8	4	50	0,16	P20264
Black										P30264
Green	DZ/41	46	2,5	3	41	11,5	4	50	0,17	P20266
Black										P30266
Green	DZ/31	43	3	4	31	15	3	50	0,21	P20268
Black										P30268

COLOUR	C	W	h	i	D	H	A	L	Kg/m	COD.
Green	DL/31	31	-	4	21	9	-	50	0,17	P20263
Black										P30263
Green	DL/31	41	-	4	31	9	-	50	0,17	P20265
Black										P30265
Green	DL/21	41	-	3	31	7	-	50	0,17	P20267
Black										P30267
Green	DL/37	42	-	4	36,5	7	-	50	0,17	P20272
Green	DL/24	34	-	7	24	15	-	2	0,32	P20296L2
Green	DL/41	45	-	3	40,5	9	-	50	0,16	P20297
Green	DL/29	39	-	5	29	18	-	2	0,33	P20298L2

Polyethylene UHMW 1000 "DESLIDUR" guide as in the table.

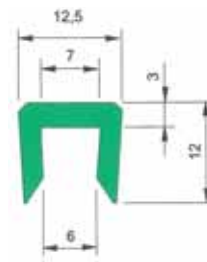

COLOUR	L	Kg/m	COD.
White	50	0,08	P10286
Green	50	0,08	P20286

Wear strip to be used with plate width of 2 to 3 mm.  
Wear strip to be used with plate width of 5 to 6 mm.

Polyethylene UHMW 1000 "DESLIDUR" guide as in the table.

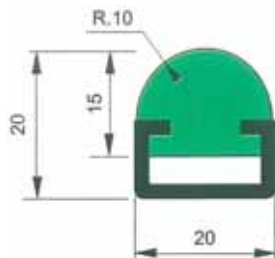

COLOUR	GUIDE	L	Kg/m	COD.
Green	-	50	0,21	P20350
Black	-	50	0,21	P30350
Green	C 2010 SS	2	0,70	PSS20350L2
		3		PSS20350L3
Green	C 2010	2	0,70	PZN20350L2
		3		PZN20350L3
Black	C 2010 SS	2	0,70	PSS30350L2
		3		PSS30350L3
Black	2010	2	0,70	PZN30350L2
		3		PZN30350L3

UHMW 1000 "DESLIDUR" Polyethylene.

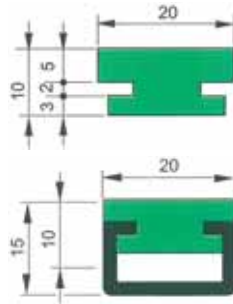

COLOUR	GUIDE	L	Kg/m	COD.
Green	-	50	0,16	P20352

COLOUR	GUIDE	L	Kg/m	COD.
Green	C 2010 SS	2	0,65	PSS20352L2
		3		PSS20352L3
Green	C 2010	2	0,65	PZN20352L2
		3		PZN20352L3

SECTION "H" GUIDE

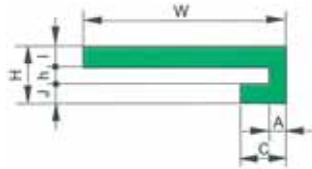

COLOUR	W	H	I	J	C	h	A	L	Kg/m	COD.
Green	23	10	4	3	11	3	3	2	0,11	P20312
Green	35	10	3,6	3,6	8	2,8	3	2	0,14	P20311
Green	40	8	3	2	25	3	10	2	0,19	P20310
Green	45	14	3	2,5	10	8,5	4	2	0,19	P20373

SECTION "L" GUIDE

UHMW 1000 "DESLIDUR" Polyethylene.

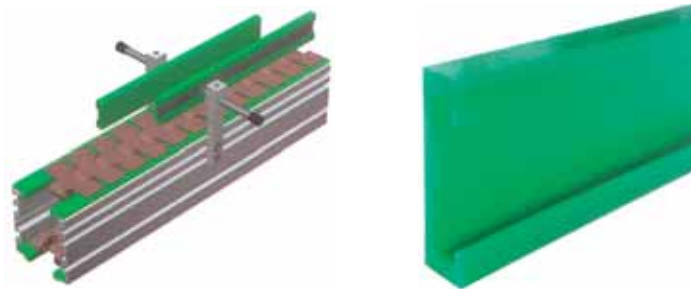

SECTION "C" GUIDE

Metallic plate.

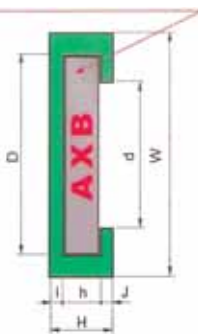

COLOUR	For steel			W	H	i	h	J	D	d	L	Kg/m	COD.
	A	X	B										
Green	20	3	30	12	3	3,5	5,5	21	12	2	0,22	P20364L2	
Green	20	5	30	12	3,5	5,2	3,3	20,5	12	2	0,17	P20365	
Green	30	3	40	10	3,5	3,5	3	30,5	23	50	0,19	P20370	
Green	40	4	50	10,5	3	4,5	3	41	29	50	0,24	P20367	
Green	40	6	50	12	3	6,5	2,5	40,3	28,5	2	0,24	P20369L2	
Green	40	8	50	14	3	8,3	2,7	41	30	50	0,26	P20371	
Green	40	10	50	16	3	10,3	2,7	41	30	2	0,27	P20372	
Green	50	6	60	12	3	6,5	2,5	51	35	50	0,28	P20374	
Black	80	5	90	12	4	5,5	2,5	81	70	2	0,42	P30392L2	

Other sizes on request.

UHMW 1000 "DESLIDUR" Polyethylene.

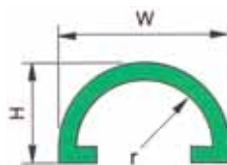

COLOUR		W	H	r	L	Kg/m	COD.
White	Clip MC 10 mm - 3/8"	25	15	10	50	0,10	P10386
Green						0,10	P20386
White	Clip MC 8 mm - 5/16"	20	13	8	50	0,09	P10388
Green						0,09	P20388

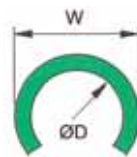

COLOUR		W	ØD	L	Kg/m	COD.
White	Clip Ø 12 - 1/2"	16,5	12	50	0,08	P10400
Green				50	0,08	P20400
White	Clip Ø 10 - 3/8"	13,8	10	50	0,07	P10402
Green				50	0,07	P20402
White	Clip Ø 8 - 1/2"	13	8	50	0,06	P10404
Green				50	0,06	P20404

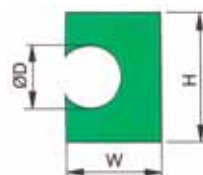

COLOUR	ØD	H	W	L	Kg/m	COD.
Green	8	20	14	2	0,21	R08
Green	10	22	16	2	0,25	R10
Green	12	24	18	2	0,29	R12

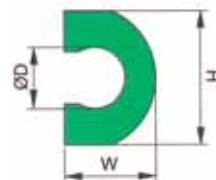

COLOUR	ØD	H	W	L	Kg/m	COD.
Green	6	20	14	2	0,21	MCH06
Green	8	20	14	2	0,19	MCH08
Green	10	22	16	2	0,22	MCH10
Green	12	24	18	2	0,25	MCH12

Guides for bottling and packaging.

UHMW 1000 "DESLIDUR" Polyethylene.

**BOTTLE GUIDE**

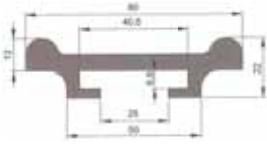

COLOUR	L	Kg/m	COD.
Black	2	0,60	P30389



COLOUR	L	Kg/m	COD.
Black	2	0,73	P30382



COLOUR	L	Kg/m	COD.
Green	2	0,76	P20384



COLOUR	L	Kg/m	COD.
Black	2	0,77	P30360L2
	3	0,77	P30360L3
	6	0,77	P30360L6

## Profiles of bevel channel

UHMW 1000 "DESLIDUR" Polyethylene.

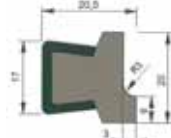

COLOUR	GUIDE	L	Kg/m	COD.
White	SS	3	0,71	CSS 10022
Black				CSS 30022

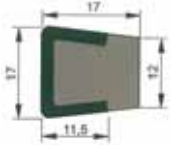

COLOUR	GUIDE	L	Kg/m	COD.
White	SS	3	0,67	CSS 10005
Black				CSS 30005

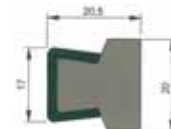

COLOUR	GUIDE	L	Kg/m	COD.
White	SS	3	0,74	CSS 10020
Black				CSS 30020

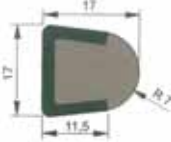

COLOUR	GUIDE	L	Kg/m	COD.
White	SS	3	0,69	CSS 10010
Black				CSS 30010

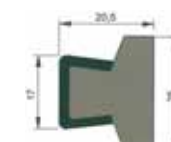

COLOUR	GUIDE	L	Kg/m	COD.
White	SS	3	0,78	CSS 10025
Black				CSS 30025

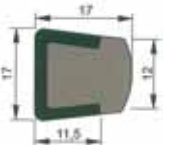

COLOUR	GUIDE	L	Kg/m	COD.
White	SS	3	0,69	CSS 10015
Black				CSS 30015



COLOUR	GUIDE	L	Kg/m	COD.
White	SS	3	0,82	CSS 10030
Black				CSS 30030

Stainless steel

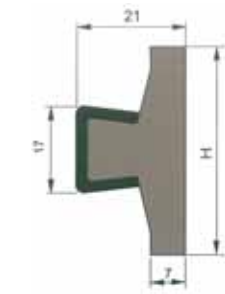

COLOUR	GUIDE	H	L	Kg/m	COD.
White	SS	40	3	0,88	CSS 10035
Black					CSS 30035
White	SS	50	2	0,95	CSS 10037L2
Black					CSS 30037L2
White	SS	60	2	1,02	CSS 10039L2
Black					CSS 30039L2

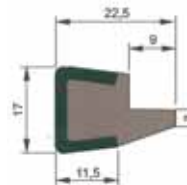

COLOUR	GUIDE	L	Kg/m	COD.
White	SS	3	0,71	CSS 10045
Black				CSS 30045

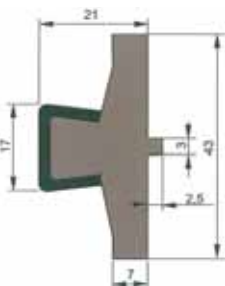

COLOUR	GUIDE	L	Kg/m	COD.
White	SS	2	0,89	CSS 10040L2
Black				CSS 30040L2

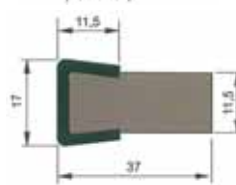

COLOUR	GUIDE	L	Kg/m	COD.
White	SS	3	0,89	CSS 10060
Black				CSS 30060

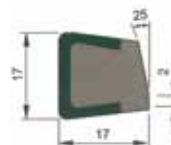

COLOUR	GUIDE	L	Kg/m	COD.
White	SS	3	0,65	CSS 10046
Black				CSS 30046

Stainless steel

UHMW 1000 "DESLIDUR" Polyethylene.

CHAIN PROFILES

Chain ISO	Pitch	W	H	A	h	L	Kg/m	COD.
06 B1	3/8"	15	10	5,4	1,5	2	0,13	S-1
08 B1	1/2"	20	10	7,4	2,2	2	0,16	S-2
08 B1	1/2"	20	15	7,4	2,2	2	0,26	S-215
10 B1	5/8"	20	10	9,2	2,6	2	0,16	S-3
10 B1	5/8"	20	15	9,2	2,6	2	0,26	S-315
12 B1	3/4"	25	10	11,3	2,4	2	0,21	S-4
12 B1	3/4"	25	15	11,3	2,4	2	0,32	S-415
16 B1	1"	40	15	16,5	3,5	2	0,47	S-5
16 B1	1"	40	20	16,5	3,5	2	0,66	S-520
20 B1	1 1/4"	45	15	19	4,3	2	0,53	S-6
20 B1	1 1/4"	45	20	19	4,3	2	0,72	S-620
24 B1	1 1/2"	60	15	24,6	5,6	2	0,78	S-7
28 B1	1 3/4"	75	20	30	6,9	2	1,13	S-8
32 B1	2"	85	20	30	7,8	2	1,21	S-9

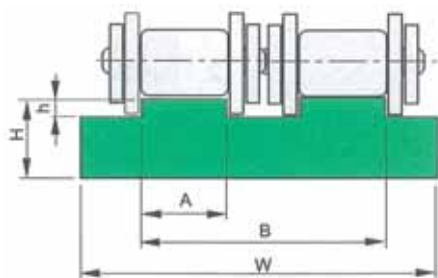
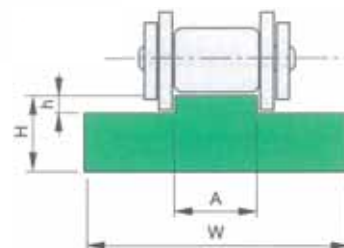

Chain ISO	Pitch	W	H	A	h	B	L	Kg/m	COD.
06 B2	3/8"	25	10	5,4	1,5	16	2	0,23	D-1
08 B2	1/2"	35	10	7,4	2,2	21	2	0,31	D-2
10 B2	5/8"	40	10	9,2	2,6	26	2	0,34	D-3
10 B2	5/8"	40	15	9,2	2,6	26	2	0,52	D-315
12 B2	3/4"	45	10	11,3	2,4	31	2	0,40	D-4
12 B2	3/4"	45	15	11,3	2,4	31	2	0,60	D-415

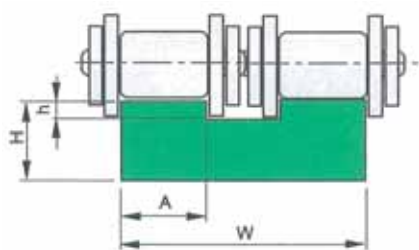

Chain ISO	Pitch	W	H	A	h	L	Kg/m	COD.
16 B2	1"	48	15	16,5	3,5	2	0,86	D-5
16 B2	1"	48	20	16,5	3,5	2	1,16	D-520
20 B2	1 1/4"	55	15	19	4,3	2	0,91	D-6
20 B2	1 1/4"	55	20	19	4,3	2	1,23	D-620
24 B2	1 1/2"	72	20	24,6	5,6	2	1,50	D-7
28 B2	1 3/4"	89	20	30	6,9	2	1,79	D-8
32 B2	2"	89	20	30	7,8	2	1,75	D-9

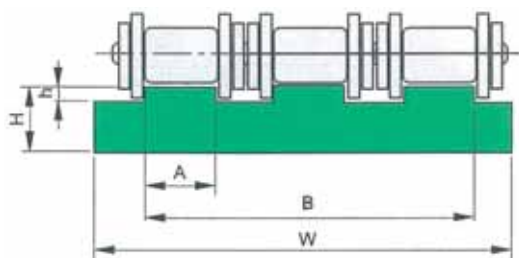

Chain ISO	Pitch	W	H	A	h	B	L	Kg/m	COD.
06 B3	3/8"	35	10	5,4	1,5	25,9	2	0,31	T-1
08 B3	1/2"	45	10	7,4	2,2	35,3	2	0,38	T-2
08 B3	1/2"	45	15	7,4	2,2	35,3	2	0,59	T-2.15
08 B3	1/2"	45	20	7,4	2,2	35,3	2	0,81	T-2.20
10 B3	5/8"	55	10	9,2	2,6	42,5	2	0,45	T-3
12 B3	3/4"	65	10	11,3	2,4	50,3	2	0,55	T-4
16 B3	1"	95	15	16,5	3,5	80,3	2	1,17	T-5

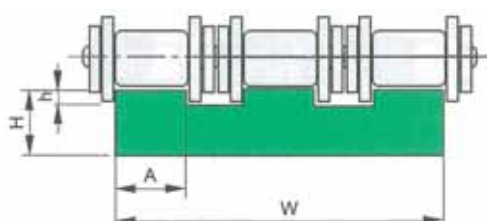

Chain ISO	Pitch	W	H	A	h	L	Kg/m	COD.
20 B3	1 1/4"	92	15	19,0	4,3	2	1,30	T-6
24 B3	1 1/2"	121	20	24,6	5,6	2	2,25	T-7
28 B3	1 3/4"	149	25	30,0	6,9	2	3,52	T-8
32 B3	2"	149	30	30,0	7,8	2	4,26	T-9

UHMW 1000 "DESLIDUR" Polyethylene.

**CHAIN PROFILES**

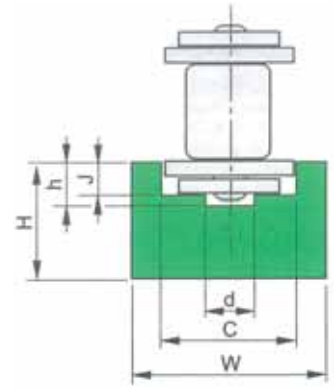

Chain ISO	Pitch	W	H	C	h	J	d	L	Kg/m	COD.
06 B	3/8"	20	15	9,2	4,2	2,8	4	2	0,26	U-1
08 B	1/2"	25	15	12,7	4,8	3,5	5	2	0,31	U-2
10 B	5/8"	25	15	15,2	5,1	3,6	6	2	0,29	U-3
12 B	3/4"	25	20	16,7	5,7	3,9	7	2	0,43	U-4
16 B	1"	35	25	24,4	10	8,4	9	2	0,62	U-5

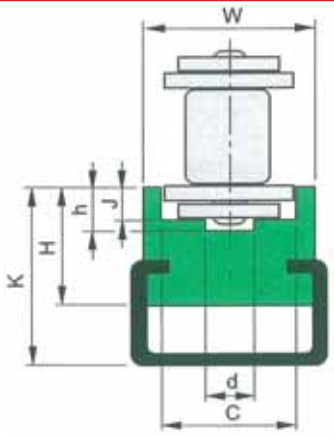

Chain ISO	Pitch	GUIDE	W	H	K	h	J	d	L	Kg/m	COD.
06 B	3/8"	C 2010	20	10	15	4,2	2,8	4	2	0,72	UCG-1
		C 2010 SS									UCG-1.SS
08 B	1/2"	C 2812	25	15	22	4,8	3,5	5	2	1,14	UCG-2
		C 2812 SS									UCG-2.SS
10 B	5/8"	C 2812	25	15	22	5,1	3,6	6	2	1,13	UCG-3
		C 2812 SS									UCG-3.SS
12 B	3/4"	C 2812	25	20	27	5,7	3,9	7	2	1,27	UCG-4
		C 2812 SS									UCG-4.SS
16 B	1"	C 3818	35	25	33	10	8,4	9	2	2,03	UCG-5
		C 3818 SS									UCG-5.SS

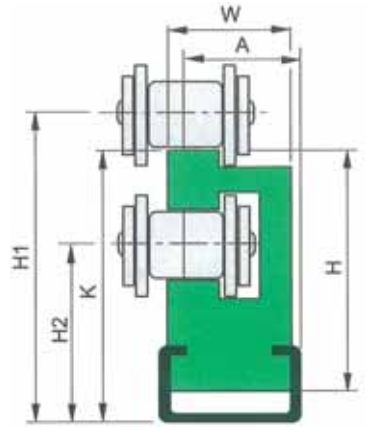

Chain ISO	Pitch	GUIDE	W	H	H1	H2	A	K	L	Kg/m	COD.
06 B1	3/8"	C 2010	20	25	30	17	14,5	27	2	0,90	2PCG-1
		C 2010 SS									2PCG-1 SS
08 B1	1/2"	C 2010	20	28	34	18	16,5	30	2	0,96	2PCG-2
		C 2010 SS									2PCG-2 SS
10 B1	5/8"	C 2010	20	33	41	21	15,5	36	2	1,12	2PCG-3
		C 2010 SS									2PCG-3 SS
12 B1	3/4"	C 2812	28	37	46,5	24	18,6	41	2	1,70	2PCG-4
		C 2812 SS									2PCG-4 SS
16 B1	1"	C 3818	38	51	62	34	25	54	2	3,10	2PCG-5
		C 3818 SS									2PCG-5 SS

Chain ISO	Pitch	GUIDE	W	H	K	h	A	L	Kg/m	COD.
06 B1	3/8"	C 2010	20	15	17	1,5	5,4	2	0,62	TCG-1
		C 2010 SS								TCG-1.SS
08 B1	1/2"	C 2010	20	15	17	2,2	7,4	2	0,69	TCG-2
		C 2010 SS								TCG-2.SS
10 B1	5/8"	C 2010	20	15	17	2,6	9,2	2	0,70	TCG-3
		C 2010 SS								TCG-3.SS
12 B1	3/4"	C 2812	28	15	18	2,4	11,3	2	1,17	TCG-4
		C 2812 SS								TCG-4.SS
16 B1	1"	C 2812	28	20	24	3,5	16,5	2	2,24	TCG-5
		C 2812 SS								TCG-5.SS
16 B1	1"	C 2812	28	15	18	3,5	16,5	2	1,25	TCG-5R
		C 2812 SS								TCG-5R.SS
20 B1	1 1/4"	C 3818	38	25	30	4,3	19,0	2	2,305	TCG-6
		C 3818 SS								TCG-6.SS
24 B1	1 1/2"	C 3818	38	25	30	5,6	24,6	2	2,390	TCG-7
		C 3818 SS								TCG-7.SS
28 B1	1 3/8"	C 3818	38	25	30	6,9	30	2	2,410	TCG-8
		C 3818 SS								TCG-8.SS
32 B1	2"	C 3818	38	25	30	7,8	30	2	2,480	TCG-9
		C 3818 SS								TCG-9.SS

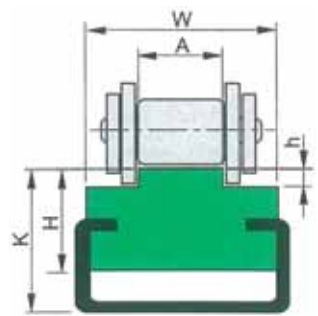

Roller chain guides

UHMW 1000 "DESLIDUR" Polyethylene.

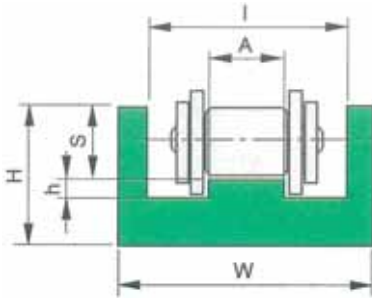

Chain ISO	Pitch	W	H	I	h	A	S	L	Kg/m	COD.
06 B1	3/8"	25	10	15	1,5	5,4	4,4	2	0,17	UC-1
08 B1	1/2"	30	15	20	2,2	7,4	7,2	2	0,27	UC-2
10 B1	5/8"	33	20	23	2,6	9,2	9,5	2	0,40	UC-3
12 B1	3/4"	38	20	28	2,4	11,3	11,1	2	0,41	UC-4
16 B1	1"	51	25	41	3,5	16,5	16,5	2	0,51	UC-5
20 B1	1 1/4"	56	30	46	4,3	19	20,7	2	0,72	UC-6

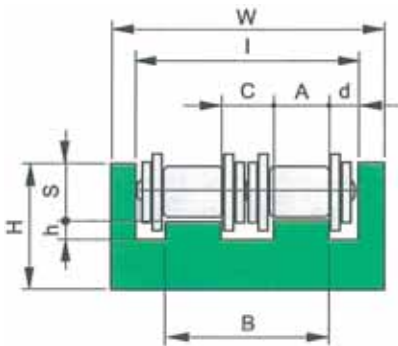

Chain ISO	Pitch	W	H	I	h	A	S	B	C	d	L	Kg/m	COD.
06 B2	3/8"	36	15	26	1,5	5,4	4,4	16	5,2	5	2	0,39	UCD-1
08 B2	1/2"	45	20	35	2,2	7,4	7,2	21	6,2	7	2	0,62	UCD-2
10 B2	5/8"	50	25	40	2,6	9,2	9,5	26	7,6	7	2	0,82	UCD-3
12 B2	3/4"	56	25	46	2,4	11,3	11,1	31	8,4	7,5	2	0,81	UCD-4
16 B2	1"	85	30	75	3,5	16,5	16,5	48,4	15,4	13,3	2	1,20	UCD-5

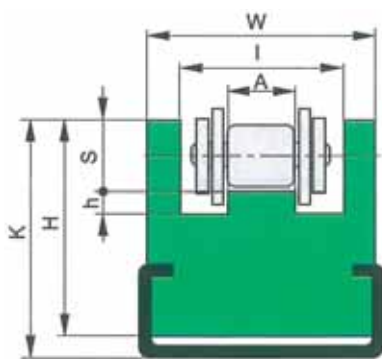

Chain ISO	Pitch	GUIDE	W	H	K	I	h	A	S	L	Kg/m	COD.
06 B1	3/8"	C 2010	25	15	18	15	1,5	5,4	4,4	2	0,76	UCCG-1
		C 2010 SS										UCCG-1.SS
08 B1	1/2"	C 2812	30	25	27	20	2,2	7,4	7,2	2	1,10	UCCG-2
		C 2812 SS										UCCG-2.SS
10 B1	5/8"	C 2812	33	30	32	23	2,6	9,2	9,5	2	1,30	UCCG-3
		C 2812 SS										UCCG-3.SS
12 B1	3/4"	C 3818	38	35	40	28	2,4	11,3	11,1	2	2,33	UCCG-4
		C 3818 SS										UCCG-4.SS
16 B1	1"	C 3818	51	40	45	41	3,5	16,5	16,5	2	2,44	UCCG-5
		C 3818 SS										UCCG-5.SS

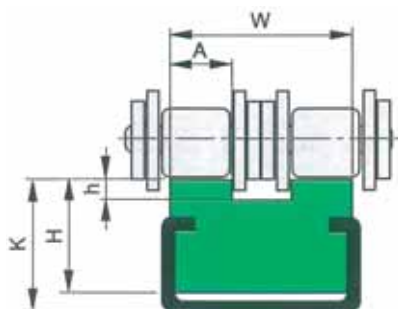

Chain ISO	Pitch	GUIDE	W	H	K	h	A	L	Kg/m	COD.
06 B2	3/8"	C 2010	20	10	15	1,5	5,4	2	0,61	TCGD-1
		C 2010 SS								TCGD-1.SS
08 B2	1/2"	C 2010	21,5	15	17	2,2	7,4	2	0,71	TCGD-2
		C 2010 SS								TCGD-2.SS
10 B2	5/8"	C 2812	28	15	17	2,6	9,2	2	1,16	TCGD-3
		C 2812 SS								TCGD-3.SS
12 B2	3/4"	C 2812	31	15	18	2,4	11,3	2	1,20	TCGD-4
		C 2812 SS								TCGD-4.SS

UHMW 1000 "DESLIDUR" Polyethylene.

**CHAIN PROFILES**

Chain ISO	Pitch	W	H	C	h	I	J	d	D	L	Kg/m	COD.
06 B	3/8"	20	25	9,3	10	5,6	8,7	4	6,6	2	0,41	GH-1
08 B	1/2"	24	30	12,8	12,7	7,6	11,5	5	8,7	2	0,56	GH-2
10 B	5/8"	30	35	15,4	14,8	9,5	16,5	6	10,4	2	0,83	GH-3
12 B	3/4"	40	35	16,9	17,5	11,5	15,9	7	12,3	2	1,11	GH-4
16 B	1"	40	45	24,4	28,2	15,9	25,7	9	16,2	2	1,23	GH-5
20 B	1 1/4"	50	50	27,5	31,2	19,4	29,3	11	19,3	2	1,73	GH-6
24 B	1 1/2"	60	60	36,5	40,1	25,2	38,2	16	25,7	2	2,33	GH-7
28 B	1 3/4"	70	70	41,5	48,9	30,8	46,9	17	28,3	2	3,17	GH-8
32 B	2"	75	75	44,5	53,0	30,8	47,3	19	29,6	2	3,26	GH-9

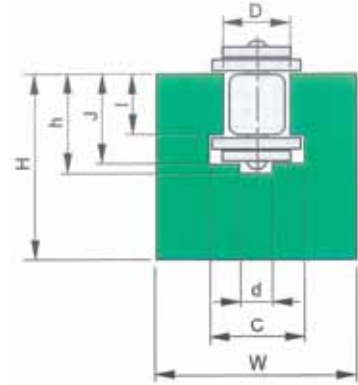

Chain ISO	Pitch	GUIDE	W	K	I	D	L	Kg/m	COD.
06 B	3/8"	C 3024	30	24	5,6	6,6	2	1,37	GHCG-1
		C 3024 SS							GHCG-1.SS
08 B	1/2"	C 3024	30	24	7,6	8,7	2	1,35	GHCG-2
		C 3024 SS							GHCG-2.SS
08 B	1/2"	C 2816	28	16	7,6	8,7	2	1,26	GHCG-2E
		C 2816 SS							GHCG-2E.SS
10 B	5/8"	C 3024	30	24	9,3	10,4	2	1,30	GHCG-3
		C 3024 SS							GHCG-3.SS
12 B	3/4"	C 3024	30	24	11,5	12,3	2	1,26	GHCG-4
		C 3024 SS							GHCG-4.SS
16 B	1"	C 4540	45	40	15,9	16,2	2	2,93	GHCG-5
		C 4540 SS							GHCG-5.SS

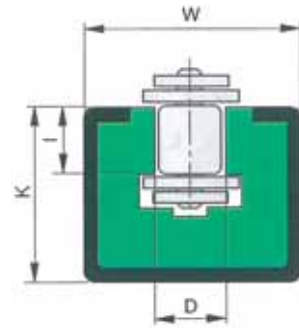

Chain ISO	Pitch	GUIDE	W	H	K	I	J	h	d	D	C	L	Kg/m	COD.
06 B	3/8"	C 2010	20	17,5	21	5,6	8,7	9,9	4	6,6	9,3	2	0,62	GHLCG-1
		C 2010 SS												GHLCG-1.SS
08 B	1/2"	C 2812	28	27,5	32	7,6	11,5	12,7	5	8,7	12,8	2	1,45	GHLCG-2
		C 2812 SS												GHLCG-2.SS
10 B	5/8"	C 2812	28	27,5	32	9,3	13,5	14,8	6	10,4	15,4	2	1,40	GHLCG-3
		C 2812 SS												GHLCG-3.SS
12 B	3/4"	C 3818	38	34,0	43	11,5	15,9	17,5	7	12,3	16,9	2	1,71	GHLCG-4
		C 3818 SS												GHLCG-4.SS
16 B	1"	C 3818	38	40	50	15,9	25,7	28,2	9	16,2	24,4	2	1,60	GHLCG-5
		C 3818 SS												GHLCG-5.SS
20 B	1 1/4"	C 6020	60	45	55	19,4	29,3	31,2	11	19,3	27,5	2	4,80	GHLCG-6
		C 6020 SS												GHLCG-6.SS
24 B	1 1/2"	C 6020	60	55	65	25,2	38,2	40,1	16	25,7	36,5	2	5,00	GHLCG-7
		C 6020 SS												GHLCG-7.SS
28 B	1 3/4"	C 6020	70	70	80	30,8	46,9	48,9	17	28,3	41,5	2	6,20	GHLCG-8
		C 6020 SS												GHLCG-8.SS
32 B	2"	C 6020	70	70	80	30,8	47,3	53,0	19	29,6	44,5	2	6,20	GHLCG-9
		C 6020 SS												GHLCG-9.SS

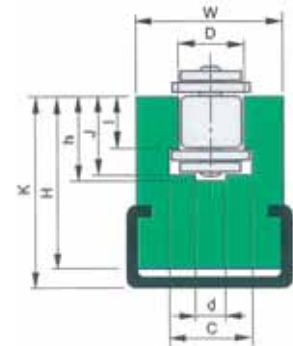

Roller chain guides

Chain ISO	Pitch	GUIDE	W	K	L	I	J	h	d	D	L	Kg/m	COD.
06 B	3/8"	C 5325	31	25	53	5,6	8,7	9,9	4	6,6	2	2,34	GHPCG-1
		C 5325 SS											GHPCG-1.SS
08 B	1/2"	C 5325	31	25	53	7,6	11,5	12,7	5	8,7	2	2,30	GHPCG-2
		C 5325 SS											GHPCG-2.SS
10 B	5/8"	C 5325	31	25	53	9,3	13,5	14,8	6	10,4	2	2,25	GHPCG-3
		C 5325 SS											GHPCG-3.SS
12 B	3/4"	C 5325	31	25	53	11,5	15,9	17,5	7	12,3	2	2,25	GHPCG-4
		C 5325 SS											GHPCG-4.SS

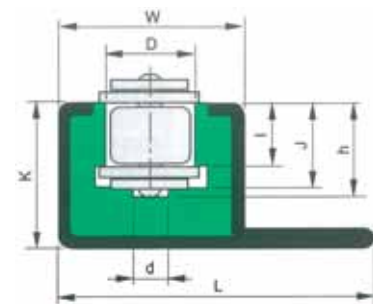



UHMW 1000 "DESLIDUR" Polyethylene.

Chain ISO	Pitch	GUIDE	W	K	L	I	J	h	d	D	L	Kg/m	COD.
06 B	3/8"	C 4731	25	31	47	5,6	8,7	9,9	4	6,6	2	2,15	GHGCG-1
		C 4731 SS											GHGCG-1.SS
08 B	1/2"	C 4731	25	31	47	7,6	11,5	12,7	5	8,7	2	2,15	GHGCG-2
		C 4731 SS											GHGCG-2.SS
10 B	5/8"	C 4731	25	31	47	9,3	13,5	14,8	6	10,4	2	2,10	GHGCG-3
		C 4731 SS											GHGCG-3.SS
12 B	3/4"	C 4731	25	31	47	11,5	15,9	17,5	7	12,3	2	2,06	GHGCG-4
		C 4731 SS											GHGCG-4.SS

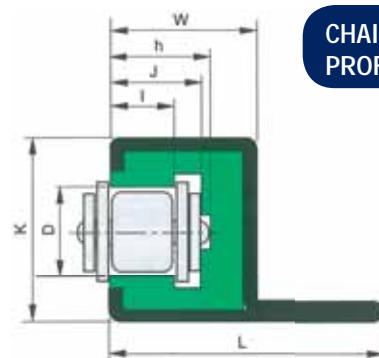

CHAIN PROFILES

## Flat belt, V-belt and cable guides

BELT PROFILES

GUIDE	W	K	H	h	L	Kg/m	COD.
C 2405	20	6	5	0,8	2	0,35	HCG 2006
C 2405 SS							HCG 2006.SS
C 2405	20	11	10	5,8	2	0,45	HCG 2011
C 2405 SS							HCG 2011.SS
C 2010	20	14	10	4	2	0,79	HCG 2014
C 2010 SS							HCG 2014.SS
C 2010	20	17	15	7	2	0,88	HCG 2017
C 2010 SS							HCG 2017.SS
C 2010	20	22	20	12	2	0,94	HCG 2022
C 2010 SS							HCG 2022.SS
C 2812	28	15	10	3	2	1,18	HCG 2815
C 2812 SS							HCG 2815.SS
C 2812	28	18	15	6	2	1,32	HCG 2818
C 2812 SS							HCG 2818.SS
C 2812	28	24	20	12	2	1,49	HCG 2824
C 2812 SS							HCG 2824.SS
C 3818	38	22	12	4	2	2,20	HCG 3822
C 3818 SS							HCG 3822.SS
C 3818	38	24	15	6	2	2,46	HCG 3824
C 3818 SS							HCG 3824.SS
C 3818	38	30	20	12	2	2,69	HCG 3830
C 3818 SS							HCG 3830.SS
C 6020	60	30	20	10	2	3,26	HCG 6030
C 6020 SS							HCG 6030.SS

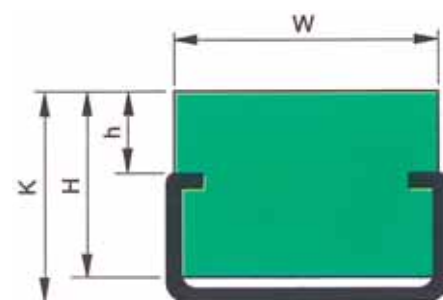
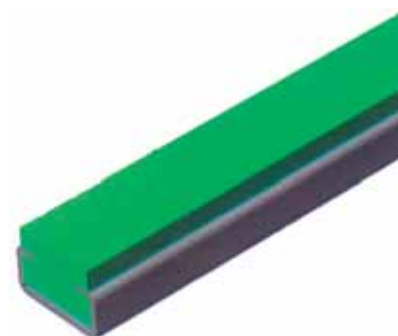

GUIDE	W	H	h	K	A	L	Kg/m	COD.
C 2010	20	15	3	17	6,5	2	0,79	CTCG 10 Z
C 2010 SS								CTCG 10 Z.SS
C 2010	20	15	5	17	8	2	0,78	CTCG 13 A
C 2010 SS								CTCG 13 A.SS
C 2812	25	20	5	24	10	2	1,35	CTCG 15 E
C 2812 SS								CTCG 15 E.SS
C 2812	30	20	8	24	10,5	2	1,44	CTCG 17 B
C 2812 SS								CTCG 17 B.SS
C 3818	38	25	11	32	13,5	2	2,26	CTCG 22 C
C 3818 SS								CTCG 22 C.SS
C 3818	40	30	13	35	19	2	2,57	CTCG 30 D
C 3818 SS								CTCG 30 D.SS

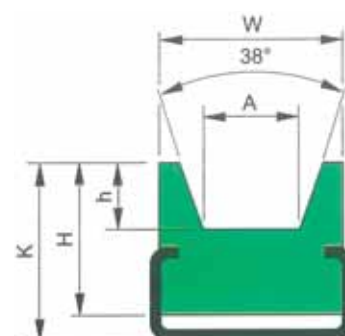

Roller chain guides/  
Flat belt, V-belt and cable guides

**STEEL PROFILES**

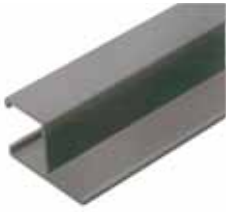

GUIDE	L	Kg/m	COD.
ZN	2	2,16	C 6020
SS	2	2,16	C 6020 SS

GUIDE	L	Kg/m	COD.
ZN	2	1,20	C 4731
SS	2	1,20	C 4731 SS

GUIDE	L	Kg/m	COD.
ZN	2	1,20	C 5325
SS	2	1,20	C 5325 SS

GUIDE	W	H	C	J	L	Kg/m	COD.
ZN	24	5,2	17,5	1	2	0,28	C 2405
SS					2	0,28	C 2405 SS
ZN	20	10	10	1,5	2	0,49	C 2010
SS					2	0,49	C 2010 SS
ZN	28	12	14	2	2	0,86	C 2812
SS					2	0,86	C 2812 SS
ZN	28	16	14	2,5	2	1,16	C 2816
SS					2	1,16	C 2816 SS
ZN	38	18	22	2,5	2	1,43	C 3818
SS					2	1,43	C 3818 SS
ZN	30	24	20	1,5	2	0,94	C 3024
SS					2	0,94	C 3024 SS
ZN	45	40	31	2	2	2,05	C 4540
SS					2	2,05	C 4540 SS

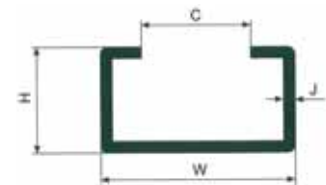
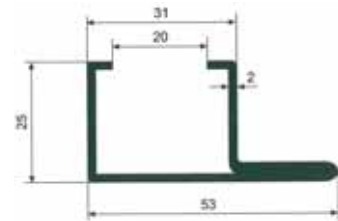
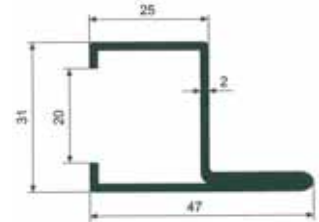
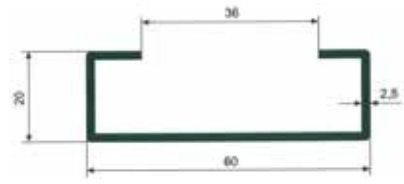

Standard length of Deslidur and steel profiles 2 mm. other lengths available on request.



Machine feet in base sizes from Ø40 to Ø125 are available in reinforced polyamide or stainless steel. Along with hinges or handles in different kinds of plastic materials or in stainless steel, we make it possible for you, to choose your preferred execution. The spindle material for the polyamide base feet can be supplied in either zink plated or stainless steel.



## Fixed feet

Ø 50  
Part. 7

ø d	A mm	H mm	Spindle in zinc plated steel	Spindle in zinc plated steel AISI 304	Max. static load N
			Code	Code	
M8	35	21	7/7370	7/7371	5000
	40	26	7/7372	7/7373	
	45	31	7/7374	7/7375	
	50	36	7/7376	7/7377	
	60	41	7/7378	7/7379	
M10	35	21	7/7380	7/7381	
	40	26	7/7382	7/7383	
	45	31	7/7384	7/7385	
	50	36	7/7386	7/7387	
	60	41	7/7388	7/7389	

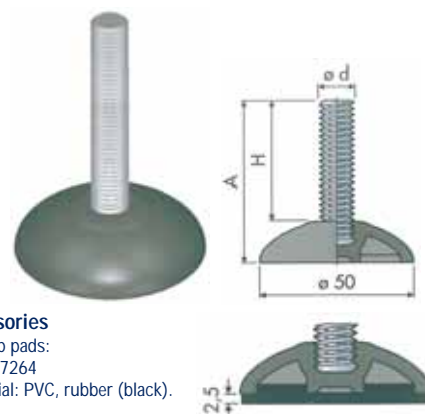

**Accessories**  
Anti-slip pads:  
- code: 7264  
- material: PVC, rubber (black).

Fixed feet

# Articulated feet - base in reinforced polyamide

**Ø 40**  
Part. 10

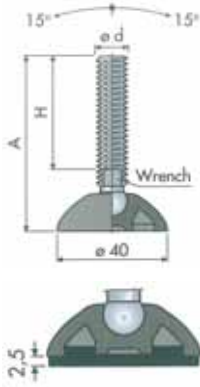

**Accessories**  
Anti-slip pads:  
- code: 7263  
- material: PVC, rubber (black).

ø d	A mm	H mm	Wrench mm	Spindle in zinc plated steel		Max. static load N
				Code	Code	
M8	68	45	6	10/7390	10/7391	10000
	88	65	6	10/7392	10/7393	
M10	60	35	8	10/7000	10/7001	11000
	95	70	8	10/7002	10/7003	
	140	115	8	10/7004	10/7005	
M12	70	43	10	10/7006	10/7007	12000
	90	63	10	10/7008	10/7009	
	105	77	10	10/7394	10/7395	
	120	93	10	10/7010	10/7011	
	150	123	10	10/701	10/7013	
M14	90	61	12	10/7014	10/7015	13000
	120	91	12	10/7016	10/7017	

**Ø 50**  
Part. 15

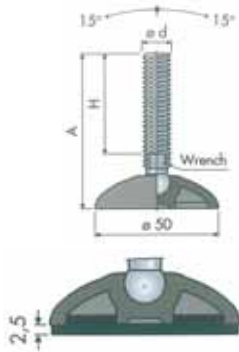

**Accessories**  
Anti-slip pads:  
- code: 7264  
- material: PVC, rubber (black).

ø d	A mm	H mm	Wrench mm	Spindle in zinc plated steel	Spindle in zinc plated steel	Max. static load N
				Code	AISI 304 Code	
M8	68	45	6	15/7396	15/7397	11000
	88	65	6	15/7398	15/7399	
M10	60	35	8	15/7018	15/7019	11000
	95	70	8	15/7020	15/7021	
	140	115	8	15/7022	15/7023	
M12	70	43	10	15/7024	15/7025	12000
	90	63	10	15/7026	15/7027	
	105	77	10	15/7400	15/7401	
	120	93	10	15/7028	15/7029	
	150	123	10	15/7030	15/7032	
M14	90	61	12	15/7032	15/7033	13000
	120	91	12	15/7034	15/7035	

**Ø 60**  
Part. 18

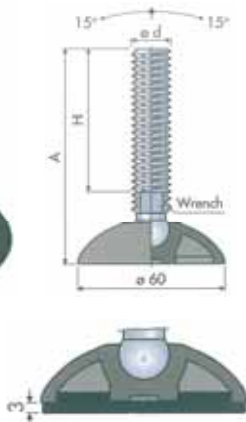

**Accessories**  
Anti-slip pads:  
- code: 7265  
- material: PVC, rubber (black).

ø d	A mm	H mm	Wrench mm	Spindle in zinc plated steel		Max. static load N
				Code	Code	
M8	72	45	6	18/7402	18/7403	12000
	92	65	6	18/7404	18/7405	
M10	64	35	8	18/7036	18/7037	13000
	99	70	8	18/7038	18/7039	
	144	115	8	18/7040	18/7041	
M12	74	43	10	18/7042	18/7043	14000
	94	63	10	18/7044	18/7045	
	109	77	10	18/7406	18/7407	
	124	93	10	18/7046	18/7047	
	154	123	10	18/7048	18/7049	
M14	94	61	12	18/7050	18/7051	15000
	124	91	12	18/7052	18/7053	
M16	95	60	13	18/7054	18/7055	17000
	125	90	13	18/7408	18/7409	
	140	105	13	18/7056	18/7057	
	160	125	13	18/7058	18/7059	
	190	155	13	18/7410	18/7411	
	200	165	13	18/7060	18/7061	
M20	125	86	17	18/7062	18/7063	19000
	155	116	17	18/7064	18/7065	
	180	141	17	18/7066	18/7067	
	245	206	17	18/7068	18/7069	

Fixed feet/  
Articulated feet

**60X95**  
Part. 27

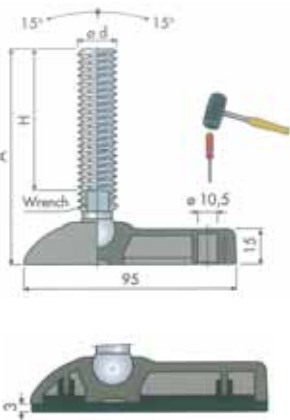

**Accessories**  
Anti-slip pads:  
- code: 7632  
- material: PVC, rubber (black).

ø d	A mm	H mm	Wrench mm	Spindle in zinc plated steel	Spindle in zinc plated steel	Max. static load N
				Code	AISI 304 Code	
M8	72	45	6	27/7412	27/7413	12000
	92	65	6	27/7414	27/7415	
M10	64	35	8	27/7416	27/7417	13000
	99	70	8	27/7418	27/7419	
	144	115	8	27/7420	27/7421	
M12	74	43	10	27/7422	27/7423	14000
	94	63	10	27/7424	27/7425	
	109	77	10	27/7426	27/7427	
	124	93	10	27/7428	27/7429	
	154	123	10	27/7430	27/7431	
M14	94	61	12	27/7432	27/7433	15000
	124	91	12	27/7434	27/7435	
M16	95	60	13	27/7436	27/7437	17000
	125	90	13	27/7438	27/7439	
	140	105	13	27/7440	27/7441	
	160	125	13	27/7442	27/7443	
	190	155	13	27/7444	27/7445	
	200	165	13	27/7446	27/7447	
M20	125	86	17	27/7448	27/7449	19000
	155	116	17	27/7450	27/7451	
	180	141	17	27/7452	27/7453	
	245	206	17	27/7454	27/7455	

Ø 80  
Part. 25

ø d	A mm	H mm	Wrench mm	Spindle in zinc plated steel	Spindle in zinc plated steel AISI 304	Max. static load N
				Code	Code	
M8	74	45	6	25/7456	25/7457	12000
	94	65	6	25/7458	25/7459	
M10	66	35	8	25/7070	25/7071	14000
	101	70	8	25/7072	25/7073	
	146	115	8	25/7074	25/7075	
M12	76	43	10	25/7076	25/7077	15000
	96	63	10	25/7078	25/7079	
	111	77	10	25/7460	25/7462	
	126	93	10	25/7080	25/7081	
	156	123	10	25/7082	25/7083	
M14	96	61	12	25/7084	25/7085	16000
	126	91	12	25/7086	25/7087	
M16	97	60	13	25/7088	25/7089	19000
	127	90	13	25/7462	25/7463	
	142	105	13	25/7090	25/7091	
	162	125	13	25/7092	25/7093	
	192	155	13	25/7064	25/7065	
	202	165	13	25/7094	25/7095	
M20	127	86	17	25/7096	25/7097	21000
	157	116	17	25/7098	25/7099	
	182	141	17	25/7100	25/7101	
	247	206	17	25/7102	25/7103	
M24	137	96	19	25/7466	25/7467	23000
	163	122	19	25/7104	25/7105	
	182	141	19	25/7468	25/7469	
	193	152	19	25/7106	25/7107	
	217	176	19	25/7470	25/7471	
	223	182	19	25/7108	25/7109	
	341	300	19	25/7472	25/7473	

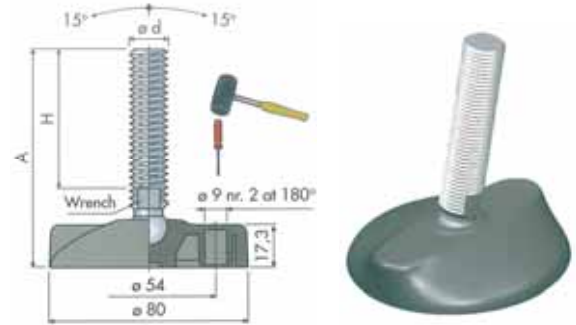

### Accessories

Anti-slip pads:  
- code: 7266  
- material: PVC, rubber (black).



ø d	A mm	H mm	Wrench mm	Spindle in zinc plated steel	Spindle in zinc plated steel AISI 304	Max. static load N
				Code	Code	
M16	100	60	13	38/7110	38/7111	22000
	130	90	13	38/7474	38/7475	
	145	105	13	38/7112	38/7113	
	165	125	13	38/7114	38/7115	
	195	155	13	38/7476	38/7477	
	205	165	13	38/7116	38/7117	
M20	130	86	17	38/7118	38/7119	24000
	160	116	17	38/7120	38/7121	
	185	141	17	38/7122	38/7123	
	250	206	17	38/7124	38/7125	
M24	140	96	19	38/7478	38/7479	26000
	166	122	19	38/7126	38/7127	
	185	141	19	38/7480	38/7481	
	196	152	19	38/7128	38/7129	
	220	176	19	38/7482	38/7483	
	226	182	19	38/7130	38/7131	
344	300	19	38/7484	38/7485		

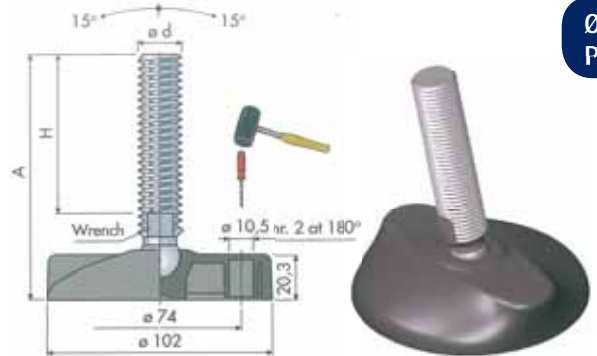

### Accessories

Anti-slip pads:  
- code: 7267  
- material: PVC, rubber (black).



Ø 102  
Part. 38

ø d	A mm	H mm	Wrench mm	Spindle in zinc plated steel	Spindle in zinc plated steel AISI 304	Max. static load N
				Code	Code	
M16	104	60	13	45/7132	45/7133	25000
	134	90	13	45/7486	45/7487	
	149	105	13	45/7134	45/7135	
	169	125	13	45/7136	45/7137	
	199	155	13	45/7488	45/7489	
	209	165	13	45/7138	45/7139	
M20	134	86	17	45/7140	45/7141	27000
	164	116	17	45/7142	45/7143	
	189	141	17	45/7144	45/7145	
	254	206	17	45/7146	45/7147	
M24	144	96	19	45/7490	45/7491	29000
	170	122	19	45/7148	45/7149	
	189	141	19	45/7492	45/7493	
	200	152	19	45/7150	45/7151	
	224	176	19	45/7494	45/7495	
	230	182	19	45/7152	45/7153	
348	300	19	45/7496	45/7497		

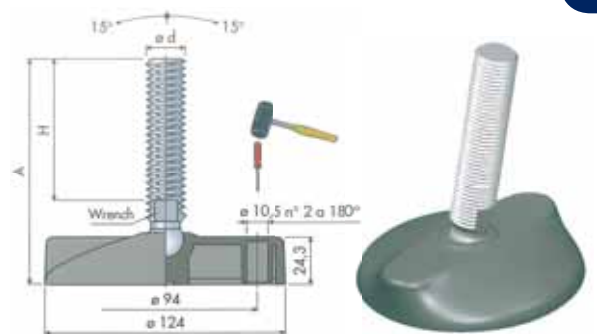

### Accessories

Anti-slip pads:  
- code: 7268  
- material: PVC, rubber (black).



Ø 124  
Part. 45

Articulated feet



STAINLESS ACCESSORIES

CODE	description	Main Dimension					
		D	D1	H	H1	G	F
30060E/27	Volantino D27 M6	27	15	30	10	10	M6
30070E/33	Volantino D33 M8	33	19	43	11	20	M8
30080E/40	Volantino D40 M8	40	21	47	15	20	M8
30090E/50	Volantino D50 M10	50	25	63	17.5	30	M10
30100E/60	Volantino D60 M12	60	27	77	20	40	M12

Stainless steel knobs - Male

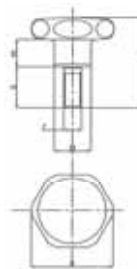

CODE	description	Main Dimension						
		A	B	I	I1	F	H	H1
60000	Cerniera inox 38X38	38	38	23	23	5	4	9
60010	Cerniera inox 50X50	50	50	33	33	5	4	9

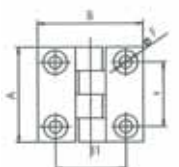

CODE	description	Main Dimension							
		A	B	I	I1	I2	F	H	H1
60012	Cerniera inox 40X58	40	58	20	24	16	5	4	9,5
60014	Cerniera inox 38X73	38	73	21	32	25,5	5	4	9,5

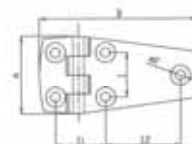

## BELTS

Steel or stainless steel woven conveyor belts is confectioned according to customer requirements. These belt types has proven themselves in applications, such as Dryers, Ovens, Shrink tunnels, De-watering applications, Separators, Baking machinery, Cheese drying applications and many more. A strong and long lasting alternative with the possibility to design almost any kind of surface, width, strength, length and surface needed.

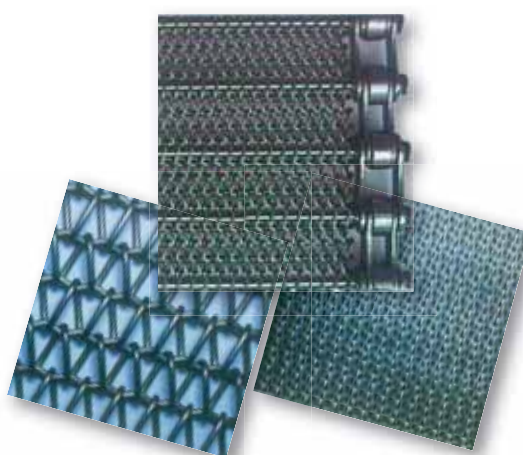

# Wired belts

WB  
Chains

Processes with all present, such as industrial deep fryers. Drying and baking ovens for foodstuffs, such as fruit, vegetables, canned food, dried fruit, etc. Incline conveyors. Surface finishing installations such as de-greasing, painting, varnishing, etc. Equipment for shrink-wrap packaging of large products.

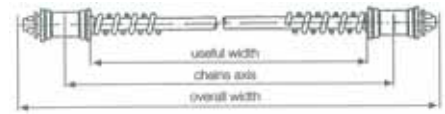
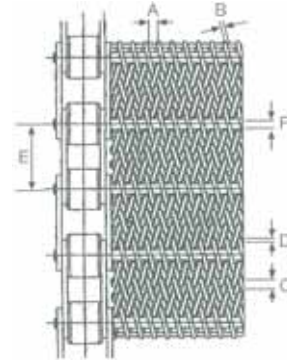

- Steel
- Stainless steel

Available with all kind of chains

WB  
8

Bread and pastry baking ovens. (bread, biscuits, fairy cakes, etc.) Animal food manufacturing processes. Heat treatment of screws and pieces of medromized little parts. Pharmaceuticals and cosmetics. Wax industry or other bead-shaped product.

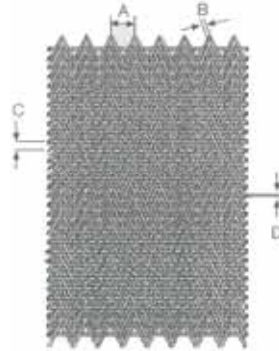

- Steel
- Stainless steel

WB  
6

Bread and pastry baking ovens. (bread, biscuits, fairy cakes, etc.) Sterilization and pasteurization processes along with cleaning and washing of fruit, vegetables and canned food. Heat treatment of components, such as annealing, normalizing, tempering and drying. Metal powder sintering processes. Equipment for shrink-wrap packing. Transporting tools with cutting edges.

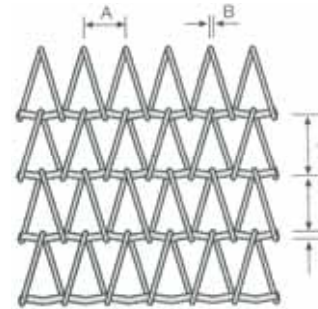
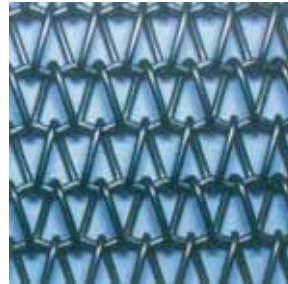

- Steel
- Stainless steel

GBSS  
101

# Stainless steel belts

Belt surface: open  
 Open area: 62%, 16x25  
 Strength: Medium and heavy application  
 Material: Stainless steel 304/316  
 Cleanability: Very good  
 Accessories: 40 mm flights  
 Application: Bakery, packaging, vegetables, washing, cooling and freezing  
 Width interval: 33 mm.

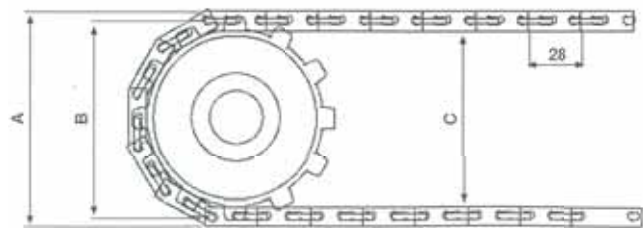
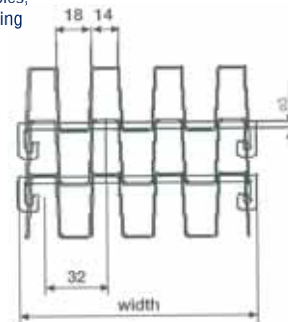
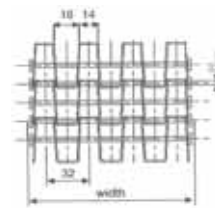

Wired belts/  
Stainless steel belts

Standard measures of the belt			
84	115	146	176
207	238	269	299
330	361	392	422
453	484	515	546
576	607	638	669
700	730	761	792
823	854	885	915
946	977	1008	1038
1069	1100	1130	1162
1192	1223	1251	1285
1316	1346	1377	1408
1439	1470	1500	1531
1562	1593	1624	1654
1685	1716	1747	1778
1808	183	1870	1900
1932	1962	1993	2024
2055	2086	216	2147
2178	2209	2240	2270
2301	2332	2363	2394
2424	2455	2486	2517

Materials	Max. belt pull kg/m of width	Belt weight kg/m
Stainless steel	4000	9,0

Hub width 16 mm	Number of teeth	
	12Z	18Z
Round bore (mm)	20	30
	25	35
	30	40
	35	45
		50
	55	
	60	

No. of teeth Z	A=Outside diameter (mm)	B=Pitch diameter (mm)	C=Inside diameter (mm)
12	119,8	109,8	99,8
18	170,0	160,0	150



# Stainless steel belts

Belt surface: perforated  
 Open area: 20 %  
 Strength: Medium and heavy application  
 Material: Stainless steel 304/316  
 Cleanability: Good  
 Accessories: 40 mm flights  
 Application: Packaging.  
 Width interval: 33 mm.

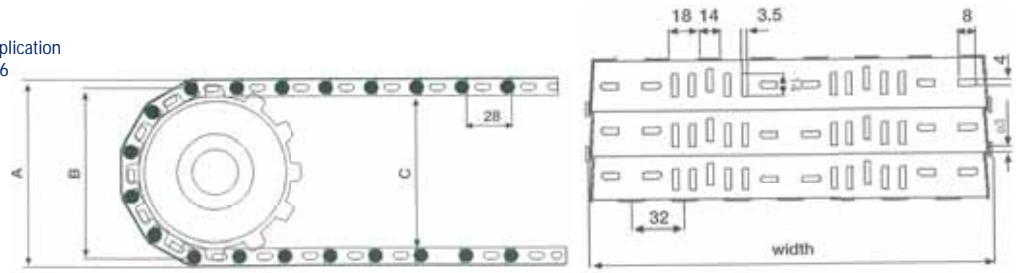

GBSS  
102

Materials	Max. belt pull kg/m of width	Belt weight kg/m
Stainless steel	4000	11,0

Hub width 16 mm	Number of teeth	
	12Z	18Z
Round bore (mm)	20	30
	25	35
	30	40
	35	45
		50
		55

No. of teeth Z	A=Outside diameter (mm)	B=Pitch diameter (mm)	C=Inside diameter (mm)
12	119,8	109,8	99,8
18	170,0	160,0	150

Belt surface: perforated  
 Open area: 10 %  
 Strength: Medium and heavy application  
 Material: Stainless steel 304/316  
 Cleanability: Good  
 Accessories: 40 mm flights  
 Application: Packaging, fruit and vegetables, washing  
 Width interval: 33 mm.

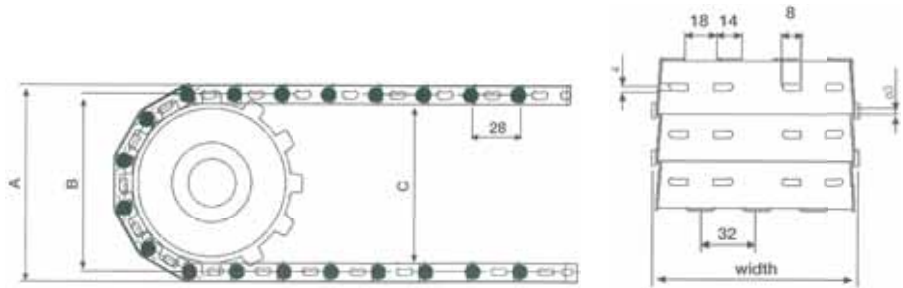

GBSS  
103

Materials	Max. belt pull kg/m of width	Belt weight kg/m
Stainless steel	4000	13,5

Hub width 16 mm	Number of teeth	
	12Z	18Z
Round bore (mm)	20	30
	25	35
	30	40
	35	45
		50
		55

No. of teeth Z	A=Outside diameter (mm)	B=Pitch diameter (mm)	C=Inside diameter (mm)
12	121,8	109,8	99,8
18	172,0	160,0	150

Belt surface: open  
 Open area: 30 %  
 Strength: Medium and heavy application  
 Material: Stainless steel 304/316  
 Cleanability: Good  
 Accessories: 40 mm flights  
 Application: Packaging, fruit and vegetables, washing  
 Width interval: 33 mm.

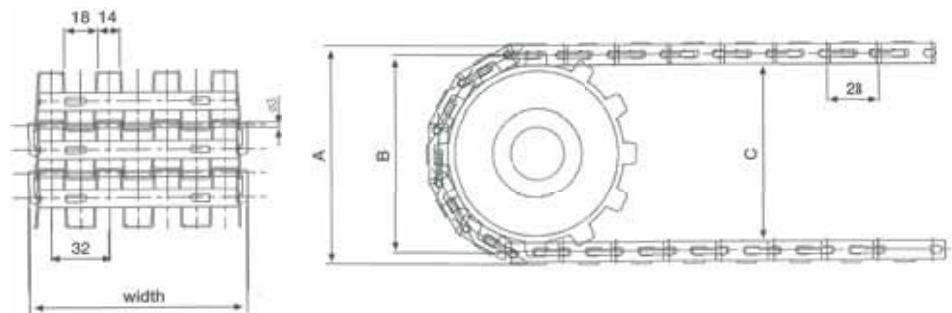

GBSS  
103

Materials	Max. belt pull kg/m of width	Belt weight kg/m
Stainless steel	4000	11,2

Hub width 16 mm	Number of teeth	
	12Z	18Z
Round bore (mm)	20	30
	25	35
	30	40
	35	45
		50
		55

No. of teeth Z	A=Outside diameter (mm)	B=Pitch diameter (mm)	C=Inside diameter (mm)
12	121,8	109,8	99,8
18	172,0	160,9	150

Stainless steel belts



In ScanBelt Hjoerring we are producing the biggest and most flexible program of Plastic Modular Conveyor belts in the market. For further details You are welcome to contact us for specific catalogues or brochures. The application possibilities are wellknown and endless.....



The worlds strongest plastic conveyor chains are produced in the same location in Hjoerring. These are widely used in the brewery sector for conveying crates, kegs and pallets. For more detailed information about these, please do not hesitate to request a special catalogue.

For more detailed information about these, please do not hesitate to request a special catalogue.

### **SCANBELT AA**

Gl. Praestegaardsvej 8B

DK-8723 Loesning

Phone: +45 7674 8600

Fax: +45 7674 8601

E-mail: [aa-chains@scanbelt.com](mailto:aa-chains@scanbelt.com)

[www.aa-chains.dk](http://www.aa-chains.dk)

### **SCANBELT A/S**

Laesovej 12

DK-9800 Hjoerring

Phone: +45 9890 9088

Fax: +45 9890 9606

E-mail: [mail@scanbelt.com](mailto:mail@scanbelt.com)

[www.scanbelt.com](http://www.scanbelt.com)